



Chipsmall Limited consists of a professional team with an average of over 10 year of expertise in the distribution of electronic components. Based in Hongkong, we have already established firm and mutual-benefit business relationships with customers from,Europe,America and south Asia,supplying obsolete and hard-to-find components to meet their specific needs.

With the principle of “Quality Parts,Customers Priority,Honest Operation,and Considerate Service”,our business mainly focus on the distribution of electronic components. Line cards we deal with include Microchip,ALPS,ROHM,Xilinx,Pulse,ON,Everlight and Freescale. Main products comprise IC,Modules,Potentiometer,IC Socket,Relay,Connector.Our parts cover such applications as commercial,industrial, and automotives areas.

We are looking forward to setting up business relationship with you and hope to provide you with the best service and solution. Let us make a better world for our industry!



Contact us

Tel: +86-755-8981 8866 Fax: +86-755-8427 6832

Email & Skype: info@chipsmall.com Web: www.chipsmall.com

Address: A1208, Overseas Decoration Building, #122 Zhenhua RD., Futian, Shenzhen, China



Future Technology Devices International Ltd.

FT311D

(USB Android Host IC)



The FT311D is a Full Speed USB host specifically targeted at providing access to peripheral hardware from an Android platform with a USB device port. The device will bridge the USB port to six user selectable interface types and has the following advanced features:

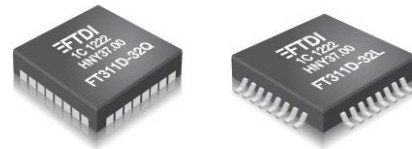

- Single chip USB to selectable interface.
- Entire USB protocol handled on the chip. No USB specific firmware programming required.
- Interface options selectable via 3 mode select pins.
- 7 GPIO lines interface option
- Basic UART interface with RXD, TXD, RTS, CTS pins option.
- TX_ACTIVE signal for controlling transceivers on RS485 interfaces.
- 4 PWM channels option.
- I²C master interface option.
- SPI Slave interface option supporting modes 0, 1, 2 and 3 with MSB/LSB options
- SPI Master interface option supporting modes 0, 1, 2 and 3 with MSB/LSB options.
- USB error indicator pin
- Suitable for use on any Android platform supporting Android Open Accessory Mode (Typically 3.1 onwards, however some platforms may port Open Accessory Mode to version 2.3.4)
- 12MHz oscillator using external crystal.
- Integrated power-on-reset circuit.
- +3V3 Single Supply Operation with 5V tolerant inputs.
- USB 2.0 Full Speed compatible.
- Extended operating temperature range; -40°C to 85°C.
- Available in compact Pb-free 32 Pin LQFP and QFN packages (both RoHS compliant).

Neither the whole nor any part of the information contained in, or the product described in this manual, may be adapted or reproduced in any material or electronic form without the prior written consent of the copyright holder. This product and its documentation are supplied on an as-is basis and no warranty as to their suitability for any particular purpose is either made or implied. Future Technology Devices International Ltd will not accept any claim for damages howsoever arising as a result of use or failure of this product. Your statutory rights are not affected. This product or any variant of it is not intended for use in any medical appliance, device or system in which the failure of the product might reasonably be expected to result in personal injury. This document provides preliminary information that may be subject to change without notice. No freedom to use patents or other intellectual property rights is implied by the publication of this document. Future Technology Devices International Ltd, Unit 1, 2 Seaward Place, Centurion Business Park, Glasgow G41 1HH United Kingdom. Scotland Registered Company Number: SC136640

1 Typical Applications

- Connecting Android phones to USB accessories
- Connecting Android tablets to USB accessories
- Controlling instrumentation from Android devices.
- Home automation via Android devices
- Data logging from USB accessories
- Connecting serial printing devices to Android devices

1.1 Part Numbers

Part Number	Package
FT311D-32Q1C-x	32 Pin QFN
FT311D-32L1C-x	32 Pin LQFP

Note: Packing codes for x is:

- R: Taped and Reel, QFN 3,000pcs per reel, LQFP 1500 pcs per reel.
- (no suffix): Tray packing, 260pcs per tray QFN, 250 pcs per tray LQFP

For example: FT311D-32Q1C-R is 3,000pcs QFN taped and reel packing

1.2 USB Compliant

At the time of writing this datasheet, the FT311D was still to complete USB compliancy testing.

2 FT311D Block Diagram

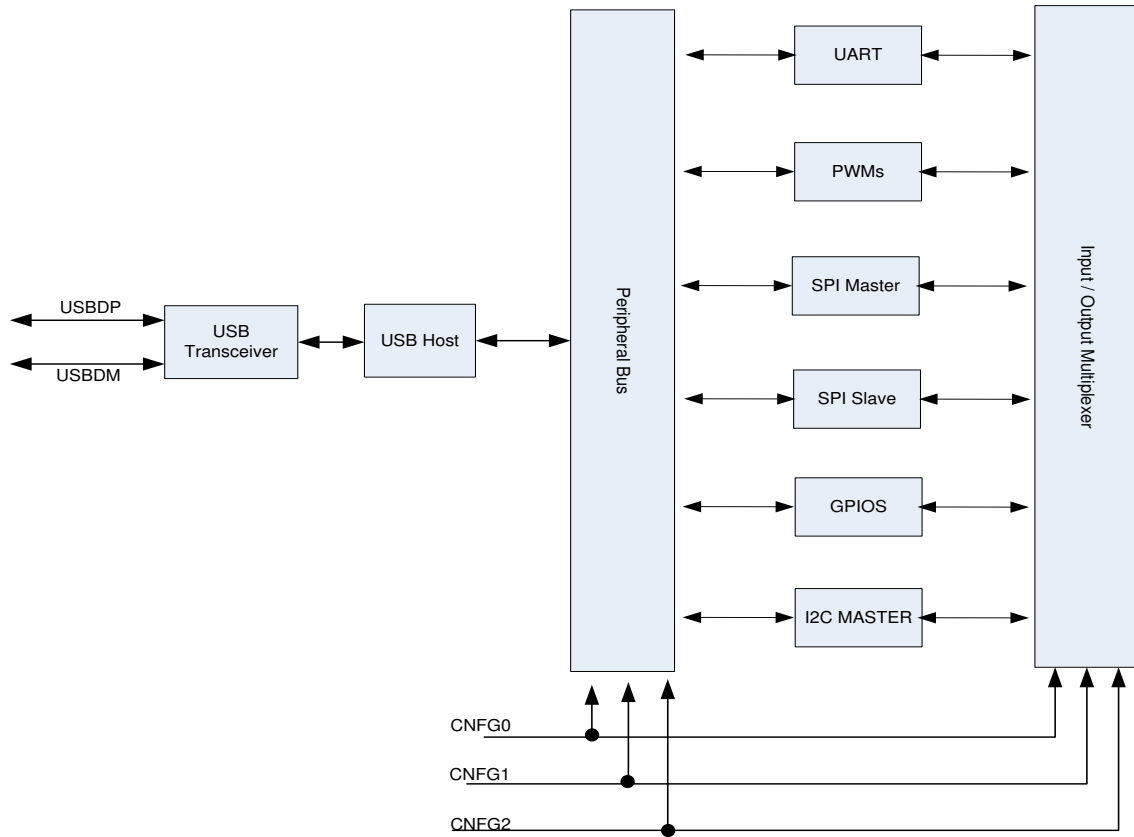

Figure 2.1 FT311D Block Diagram

For a description of each function please refer to Section 4.

Table of Contents

1	Typical Applications	2
1.1	Part Numbers	2
1.2	USB Compliant	2
2	FT311D Block Diagram	3
3	Device Pin Out and Signal Description	6
3.1	Package Symbol	6
3.1.1	Package PinOut Description.....	6
3.2	Interface Selection	8
3.2.1	Interface pinout.....	8
4	Function Description	10
4.1	Key Features	10
4.2	Functional Block Descriptions	10
4.2.1	Peripheral Interface Modules	10
4.2.2	USB Transceivers.....	10
4.2.3	USB Host.....	10
4.3	I/O Peripherals Signal Names	10
4.4	Default Mode Strings	11
5	Peripheral Interfaces	12
5.1	General Purpose Input Output	12
5.2	UART Interface	12
5.2.1	UART Mode Signal Descriptions	13
5.3	Pulse Width Modulation	13
5.4	I2C	13
5.5	Serial Peripheral Interface – SPI Modes	14
5.5.1	SPI Clock Phase Modes.....	14
5.5.2	Serial Peripheral Interface – Slave	16
5.5.3	Serial Peripheral Interface – SPI Master.....	16
6	USB Error Detection	19
7	Absolute Maximum Ratings	20
7.1	DC Characteristics	20
7.2	ESD and Latch-up Specifications	22
8	Application Examples	23
8.1	USB to GPIO Converter	23
8.2	USB to UART Converter	24
8.3	USB to PWM Converter	25
8.4	USB to I²C (Master) Converter	26

8.5	USB to SPI (Slave) Converter	27
8.6	USB to SPI (Master) Converter	28
9	Package Parameters.....	29
9.1	FT311D Package Markings	29
9.1.1	QFN-32	29
9.1.2	LQFP-32	30
9.2	FT311D Package Dimensions	31
9.2.1	QFN-32 Package Dimensions	31
9.2.2	LQFP-32 Package Dimensions.....	32
9.3	Solder Reflow Profile	33
10	Contact Information	35
	Appendix A – References	36
	Useful utilities and examples firmware.....	36
	Appendix B - List of Figures and Tables	37
	Appendix C - Revision History.....	39

3 Device Pin Out and Signal Description

3.1 Package Symbol

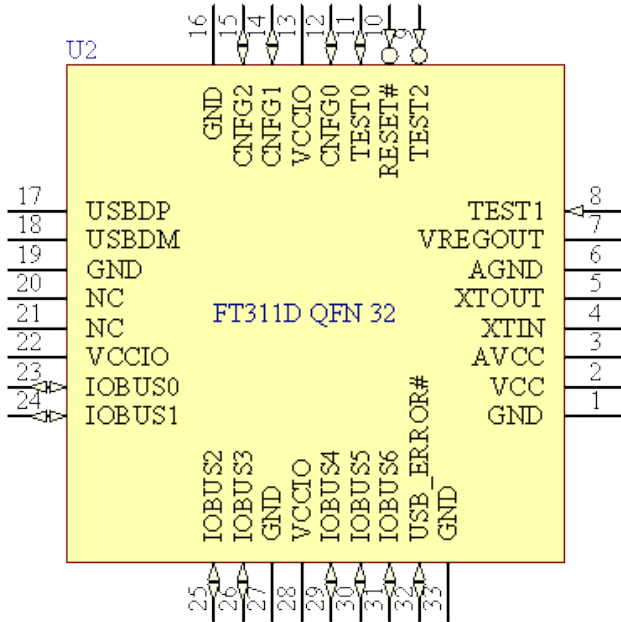

Figure 3.1 QFN Schematic Symbol

Note the pinout is the same for the QFN and LQFP packages.

3.1.1 Package PinOut Description

Note: # denotes an active low signal.

Pin No.	Name	Type	Description
2	3.3V VREGIN	POWER Input	3V3 supply to IC internal 1V8 regulator
3	1.8V VCC PLL IN	POWER Input	1V8 supply to IC core
13, 22, 28	VCCIO	POWER Input	3V3 supply for the IO cells
7	VREGOUT	POWER Output	1V8 output. May be used as input source for pin 3.
1,6,16,19,27	GND	POWER Input	0V Ground input.

Table 3.1 Power and Ground

Pin No.	Name	Type	Description
17	USBDP	INPUT/OUTPUT	USB Data Signal Plus.
18	USBDM	INPUT/OUTPUT	USB Data Signal Minus.
4	XTIN	INPUT	Input to 12MHz Oscillator Cell. Connect 12MHz crystal across pins 4 and 5.
5	XTOUT	OUTPUT	Output from 12MHz Oscillator Cell. Connect 12MHz crystal across pins 4 and 5.
8	TEST1	INPUT	For internal use. Pull to GND
9	TEST2	INPUT	For factory use. Pull to 3V3.
10	RESET#	INPUT	Reset input (active low).
20, 21	NC	-	No connect pins. Leave unterminated.
11	TEST0	OUTPUT	Active low signal that may be used to control a switch for enabling power to the USB port pin 1 (VBUS).
12	CNFG0	INPUT	Configuration pin 0 used to select between GPIO,UART,PWM,I ² C and SPI. Pull to Ground = Logic '0'(No external resistor needed) Leave Open = Logic '1' (Internal Pull up is present)
14	CNFG1	INPUT	Configuration pin 1 used to select between GPIO,UART,PWM,I ² C and SPI. Pull to Ground = Logic '0'(No external resistor needed) Leave Open = Logic '1' (Internal Pull up is present)
15	CNFG2	INPUT	Configuration pin 2 used to select between GPIO,UART,PWM,I ² C and SPI. Pull to Ground = Logic '0'(No external resistor needed) Leave Open = Logic '1' (Internal Pull up is present)
32	USB_ERROR#	OUTPUT	Output signal to indicate a problem with the USB connection

Table 3.2 Common Function pins

Pin No.	Name	Type	Description
23	IOBUS0	INPUT/OUTPUT	I/O signal. Function depends on CNFG pin setting. See table 3.4
24	IOBUS1	INPUT/OUTPUT	I/O signal. Function depends on CNFG pin setting. See table 3.4
25	IOBUS2	INPUT/OUTPUT	I/O signal. Function depends on CNFG pin setting. See table 3.4
26	IOBUS3	INPUT/OUTPUT	I/O signal. Function depends on CNFG pin setting. See table 3.4

29	IOBUS4	INPUT/OUTPUT	I/O signal. Function depends on CNFG pin setting. See table 3.4
30	IOBUS5	INPUT/OUTPUT	I/O signal. Function depends on CNFG pin setting. See table 3.4
31	IOBUS6	INPUT/OUTPUT	I/O signal. Function depends on CNFG pin setting. See table 3.4

Table 3.3 Interface Pins

Notes:

- When used in Input Mode, the input pins are pulled to VCCIO via internal 75kΩ (approx.) resistors.

3.2 Interface Selection

The FT311D has multiple interfaces available for connecting to external devices. The resources available are GPIO, UART, PWM, I2C(Master), SPI(Slave) and SPI(Master). The selection of what interface the user requires is configured using the CNFG0, CNFG1 and CNFG2 input pins as per table 3.4.

CNFG2	CNFG1	CNFG0	Mode
GND	GND	GND	GPIO
GND	GND	Leave Open	UART
GND	Leave Open	GND	PWM
GND	Leave Open	Leave Open	I2C (Master)
Leave Open	GND	GND	SPI (Slave)
Leave Open	GND	Leave Open	SPI (Master)

Table 3.4 CBUS Configuration Control

Note 1: When left open the pin is a logic 1.

Note 2: Mode "110" is a factory test mode and should not be used.

Note 3: Mode "111" will default to GPIO mode.

3.2.1 Interface pinout

The actual pinout for each interface type is detailed in table 3.5

Pin No	Pin Name	GPIO	UART	PWM	I2C (Master)	SPI (Slave)	SPI (Master)
23	IOBUS0	GPIO0	UART_TXD	PWM0	I2C_CLK	-	-
24	IOBUS1	GPIO1	UART_RXD	PWM1	I2C_DATA	-	-
25	IOBUS2	GPIO2	UART_RTS #	PWM2	-	-	-
26	IOBUS3	GPIO3	UART_CTS #	PWM3	-	SPI_S_SS0	SPI_M_SS0

Pin No	Pin Name	GPIO	UART	PWM	I2C (Master)	SPI (Slave)	SPI (Master)
29	IOBUS4	GPIO4	UART_TX_ACTIVE	-	-	SPI_S_CLK	SPI_M_CLK
30	IOBUS5	GPIO5	-	-	-	SPI_S_MOSI	SPI_M_MOSI
31	IOBUS6	GPIO6	-	-	-	SPI_S_MISO	SPI_M_MISO

Table 3.5 I/O Configuration

4 Function Description

FT311D is FTDI's Android Accessory Mode integrated circuit device or Android Host. The FT311D behaves like a bridge between an Android device and the various I/O available. Selection of various modes is performed using CNFGx pins.

4.1 Key Features

Easy to use Android accessory IC translating the Device port of the android tablet into either GPIO, UART, PWM, I²C Master, SPI Slave or SPI Master capabilities

4.2 Functional Block Descriptions

The following paragraphs describe each function within FT311D. Please refer to the block diagram shown in **Figure 2.1**.

4.2.1 Peripheral Interface Modules

FT311D has six peripheral interface modules available for selection. Full descriptions of each module are described in [Section 5](#).

- GPIO - General purpose I/O pins
- UART
- PWM
- I2C Master
- SPI Slave
- SPI Master

4.2.2 USB Transceivers

USB transceiver cells provide the physical USB device interface supporting USB 1.1 and USB 2.0 standards. Low-speed and full-speed USB data rates are supported. The output driver provides +3.3V level slew rate control signalling, whilst a differential receiver and two single ended receivers provide USB DATA IN, SE0 and USB Reset condition detection. These cells also include integrated internal pull-down resistors as required for host mode.

4.2.3 USB Host

These blocks handle the parallel-to-serial and serial-to-parallel conversion of the USB physical layer. This includes bit stuffing, CRC generation.

4.3 I/O Peripherals Signal Names

Peripheral	Signal Name	Outputs	Inputs	Description
GPIO	gpio	7	7	General purpose I/O
UART	uart_txd	1	0	Transmit asynchronous data output
	uart_rts#	1	0	Request to send control output
	uart_rxd	0	1	Receive asynchronous data input
	uart_cts#	0	1	Clear to send control input
	uart_tx_active	0	1	UART active signal (typically used with RS485)
PWM	pwm	4	0	Pulse width modulation
I ² C	I2c_scl	0	1	I2C bus serial clock line - slave
	I2c_sda	1	1	I2C bus serial data line - slave
SPI Slave	spi_s_clk	0	1	SPI clock input

	spi_s_ss#	0	1	SPI slave select input
	spi_s_mosi	1	1	SPI master out serial in
	spi_s_miso	1	0	SPI master in slave out
SPI Master	spi_m_clk	1	0	SPI clock input - master
	spi_m_mosi	1	1	Master out slave in - master
	spi_m_miso	0	1	Master in slave out - master
	spi_m_ss_0#	1	0	Active low slave select 0 from master to slave 0

Table 4.1 I/O Peripherals Signal Names

Note: # is used to indicate an active low signal.

4.4 Default Mode Strings

When the USB port is connected to the Android USB port, the Android platform will determine which application to load based on the strings read from the FT311D. These strings are configurable with a Windows utility: FT311Configuration.exe available for download from the FTDI website at:

<http://www.ftdichip.com/Android/FT311Configuration.zip>

Default values for the strings are set in the device as per Table 4.2

Descriptor String	Default Value
Manufacturer	FTDI
Model (depends on GPIO Mode selection):	
GPIO	FTDIGPIODemo
UART	FTDIUARTDemo
PWM	FTDIPWMDemo
I ² C	FTDII2CDemo
SPI Slave	FTDISPISlaveDemo
SPI Master	FTDISPIMasterDemo
Version	1.0
Serial	VinculumAccessory1
Description URL	http://www.ftdichip.com

Table 4.2 Default Descriptor Strings

5 Peripheral Interfaces

In addition to the USB Host, FT311D contains the following peripheral interfaces:

- General Purpose Input Output (GPIO)
- Universal Asynchronous Receiver Transmitter (UART)
- Four Pulse Width Modulation blocks (PWM)
- I²C Master
- Serial Peripheral Interface (SPI) Slave
- Serial Peripheral Interface (SPI) Master

Note: Only one interface may be selected at any time.

The modes are selected by setting the CNFGx pins.

The following sections describe each peripheral in detail.

5.1 General Purpose Input Output

FT311D provides up to 7 configurable Input/Output pins. All pins are independently configurable to be either inputs or outputs.

5.2 UART Interface

When the peripheral interface is configured in UART mode, the interface implements a standard asynchronous serial UART port with flow control, for example RS232/422/485. The UART can support baud rates from 300 baud to 6 Mbaud.

Data transfer uses NRZ (Non-Return to Zero) data format consisting of 1 start bit, 7 or 8 data bits, an optional parity bit, and one or two stop bits. When transmitting the data bits, the least significant bit is transmitted first. Transmit and receive waveforms are illustrated in **Figure 5-1** and **Figure 5-2**:

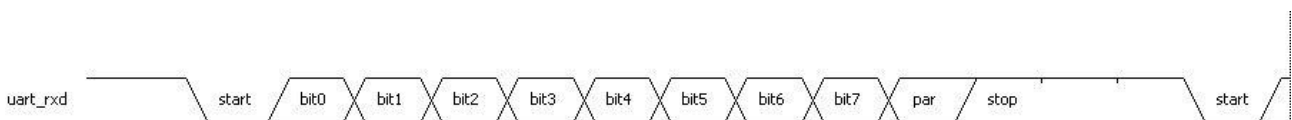

Figure 5-1 UART Receive Waveform

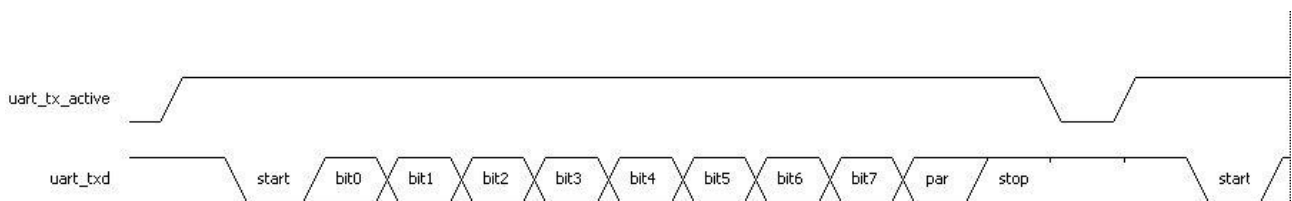

Figure 5-2 UART Transmit Waveform

Baud rate (default = 9600 baud), flow control settings (default = RTS/CTS), number of data bits (default=8), parity (default is no parity) and number of stop bits (default=1) are all configurable from the Android application. Please refer to [http://www.ftdichip.com/Support/Documents/ProgramGuides.htm/FT311 Android Programmers Guide.pdf](http://www.ftdichip.com/Support/Documents/ProgramGuides.htm/FT311_Android_Programmers_Guide.pdf) for further details.

uart_tx_active is transmit enable, this output may be used in RS485 designs to control the transmit of the line driver.

5.2.1 UART Mode Signal Descriptions

The UART signals are fixed on the I/O pins. Table 5.1 UART Interface, details the pins for each of the UART signals.

Pin No	Name	Type	Description
23	uart_txd	Output	Transmit asynchronous data output
24	uart_rxd	Input	Receive asynchronous data input
25	uart_rts#	Output	Request to send control output
26	uart_cts#	Input	Clear to send control input
29	uart_tx_active	output	Transmit enable (typically used for RS485 designs)

Table 5.1 UART Interface

5.3 Pulse Width Modulation

FT311D provides 4 Pulse Width Modulation (PWM) outputs. These can be used to generate PWM signals which can be used to control motors, DC/DC converters, AC/DC supplies, etc. Further information is available in an Application Note AN_140 - [Vinculum-II PWM Example](#).

The features of the PWM module are as follows:

- 4 PWM outputs
- Variable frequency
- Variable duty cycle

5.4 I2C

I²C (Inter Integrated Circuit) is a multi-master serial bus invented by Philips. I²C uses two bi-directional open-drain wires called serial data (SDA) and serial clock (SCL). Common I²C bus speeds are the 100 kbit/s standard mode (SM), 400 kbit/s fast mode (FM), 1 Mbit/s Fast mode plus (FM+), and 3.4 Mbit/s High Speed mode (HS)

An I²C bus node can operate either as a master or a slave:

- Master node – issues the clock and addresses slaves
- Slave node – receives the clock line and address.

FT311D provides an I2C master interface for connection to other I2C Slave interfaces up to 125kbit/s.

The master is initially in master transmit mode by sending a start bit followed by the 7-bit address of the slave it wishes to communicate with, which is finally followed by a single bit representing whether to write(0) to, or read(1) from the slave.

If the slave exists on the bus then it will respond with an ACK bit (active low for acknowledged) for that address. The master then continues in either transmit or receive mode (according to the read/write bit it sent), and the slave continues in its complementary mode (receive or transmit, respectively).

The address and the data bytes are sent most significant bit first. The start bit is indicated by a high-to-low transition of SDA with SCL high; the stop bit is indicated by a low-to-high transition of SDA with SCL high.

If the master has to write to the slave then it repeatedly sends a byte with the slave sending an ACK bit. (In this situation, the master is in master transmit mode and the slave is in slave receive mode.)

If the master has to read from the slave then it repeatedly receives a byte from the slave, the master sending an ACK bit after every byte but the last one. (In this situation, the master is in master receive mode and the slave is in slave transmit mode.)

The master then ends transmission with a stop bit, or it may send another START bit if it wishes to retain control of the bus for another transfer (a "combined message").

I²C defines three basic types of message, each of which begins with a START and ends with a STOP:

- Single message where a master writes data to a slave;
- Single message where a master reads data from a slave;
- Combined messages, where a master issues at least two reads and/or writes to one or more slaves

In a combined message, each read or write begins with a START and the slave address. After the first START, these are also called repeated START bits; repeated START bits are not preceded by STOP bits, which is how slaves know the next transfer is part of the same message.

Please refer to the I²C specification for more information on the protocol.

5.5 Serial Peripheral Interface – SPI Modes

The Serial Peripheral Interface Bus is an industry standard communications interface. Devices communicate in Master / Slave mode, with the Master initiating the data transfer.

FT311D has one master module and one slave module. Both the SPI master and slave module has four signals – clock, slave select, MOSI (master out – slave in) and MISO (master in – slave out). Table 5.2 lists how the signals are named in each module.

Module	Signal Name	Type	Description
SPI Slave	spi_s_clk	Input	Clock input
	spi_s_ss#	Input	Active low slave select input
	spi_s_mosi	Input	Master out serial in
	spi_s_miso	Output	Master in slave out
SPI Master	spi_m_clk	Output	Clock output – master
	spi_m_mosi	Output	Master out slave in - master
	spi_m_miso	Input	Master in slave out - master
	spi_m_ss_0#	Output	Active low slave select 0 from master to slave 0

Table 5.2 SPI Signal Names

The SPI slave protocol by default does not support any form of handshaking. It is simply transferring 8 bit data.

5.5.1 SPI Clock Phase Modes

SPI interface has 4 unique modes of clock phase (CPHA) and clock polarity (CPOL), known as Mode 0, Mode 1, Mode 2 and Mode 3. Table 5.3 summarizes these modes and available interface and **Figure 5-3** is the function timing diagram.

For CPOL = 0, the base (inactive) level of SCLK is 0.

In this mode:

- When CPHA = 0, data is clocked in on the rising edge of SCLK, and data is clocked out on the falling edge of SCLK.
- When CPHA = 1, data is clocked in on the falling edge of SCLK, and data is clocked out on the rising edge of SCLK

For CPOL =1, the base (inactive) level of SCLK is 1.

In this mode:

- When CPHA = 0, data is clocked in on the falling edge of SCLK, and data is clocked out on the rising edge of SCLK
- When CPHA =1, data is clocked in on the rising edge of SCLK, and data is clocked out on the falling edge of SCLK.

Mode	CPOL	CPHA
0	0	0
1	0	1
2	1	0
3	1	1

Table 5.3 - Clock Phase/Polarity Modes

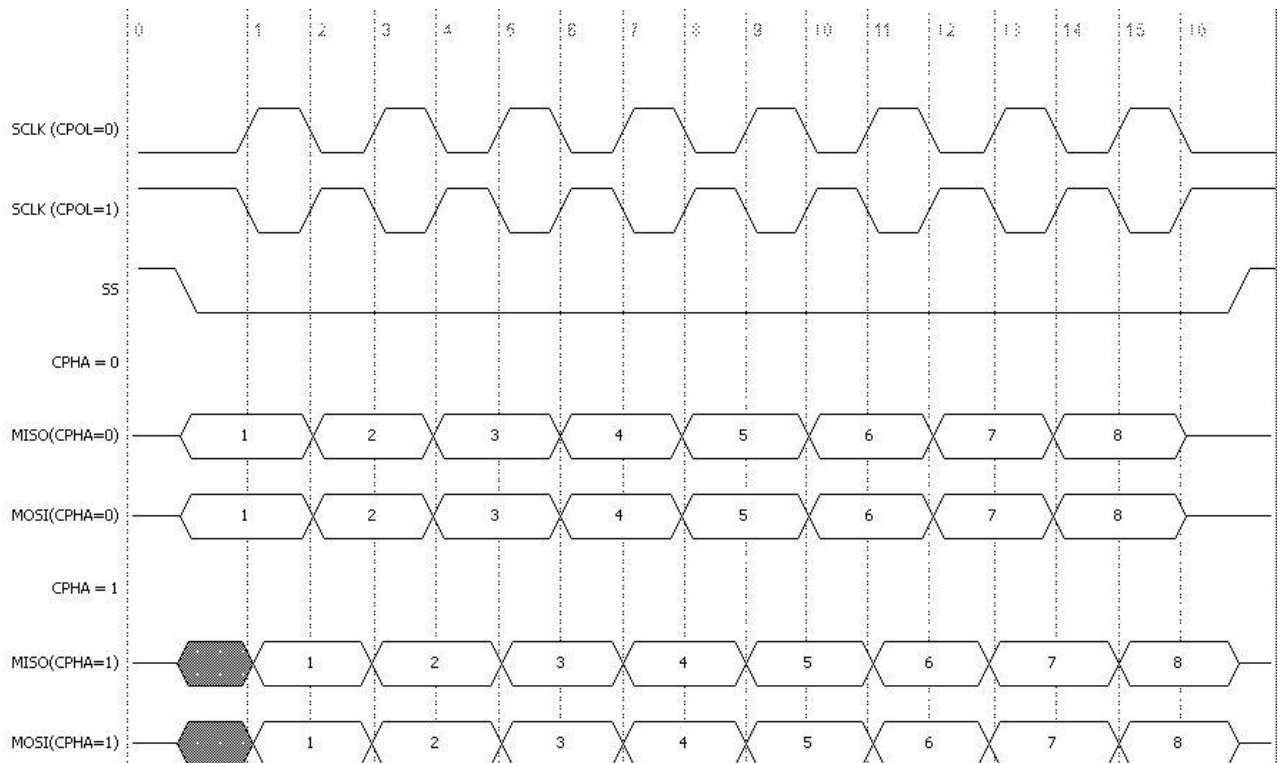

Figure 5-3 - SPI CPOL CPHA Function

5.5.2 Serial Peripheral Interface – Slave

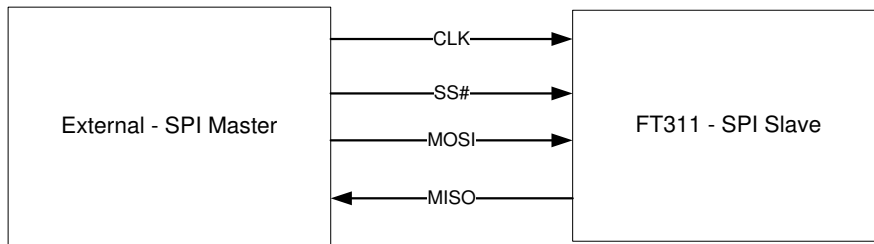

Figure 5-4 SPI Slave block diagram

FT311D has an SPI Slave module that uses four wire interfaces: MOSI, MISO, CLK and SS#. An SPI transfer can only be initiated by the SPI Master and begins with the slave select signal being asserted. This is followed by a data byte being clocked out with the master supplying CLK. The master always supplies the first byte, which is called a command byte. After this the desired number of data bytes are transferred before the transaction is terminated by the master de-asserting slave select. An SPI Master is able to abort a transfer at any time by de-asserting its SS# output. This will cause the Slave to end its current transfer and return to idle state.

5.5.2.1 SPI Slave Signal Descriptions

Pin No	Name	Type	Description
29	spi_s0_clk	Input	Slave clock input
30	spi_s0_mosi	Input	Master Out Slave In Synchronous data from master to slave
31	spi_s0_miso	Output	Master In Slave Out Synchronous data from slave to master
26	spi_s0_ss#	Input	Slave select

Table 5.4 Data and Control Bus Signal Mode Options - SPI Slave Interface

5.5.3 Serial Peripheral Interface – SPI Master

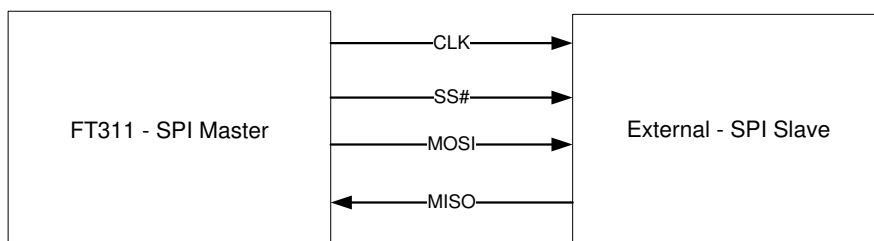

Figure 5-5 SPI Master block diagram

The SPI Master interface is used to interface to applications such as Real time clocks and audio codecs. The SPI Master provides the following features:

- Synchronous serial data link.
- Full and half duplex data transmission.
- Serial clock with programmable frequency, polarity and phase.
- One slave select output.

5.5.3.1 SPI Master Signal Descriptions.

Table 5.5 shows the SPI master signals and the pins

Pin No	Name	Type	Description
29	spi_m_clk	Output	SPI master clock input
30	spi_m_mosi	Output	Master Out Slave In Synchronous data from master to slave
31	spi_m_miso	Input	Master In Slave Out Synchronous data from slave to master
26	spi_m_ss_0#	Output	Active low slave select 0 from master to slave

Table 5.5 SPI Master Signal Names

The main purpose of the SPI Master block is to transfer data between an external SPI interface and the FT311D.

An SPI master interface transfer can only be initiated by the SPI Master and begins with the slave select signal being asserted. This is followed by a data byte being clocked out with the master supplying SCLK. The master typically supplies the first byte, which is called a command byte. After this the desired number of data bytes are transferred before the transaction is terminated by the master de-asserting slave select. However the FT311D is simply a data pipe and no command is required by the FT311D itself. Any command protocol would be defined by the Android application.

The SPI Master will transmit on MOSI as well as receive on MISO during every data stage.

Figure 5-6 Typical SPI Master Timing and Table 5.6 SPI Master Timing show an example of this.

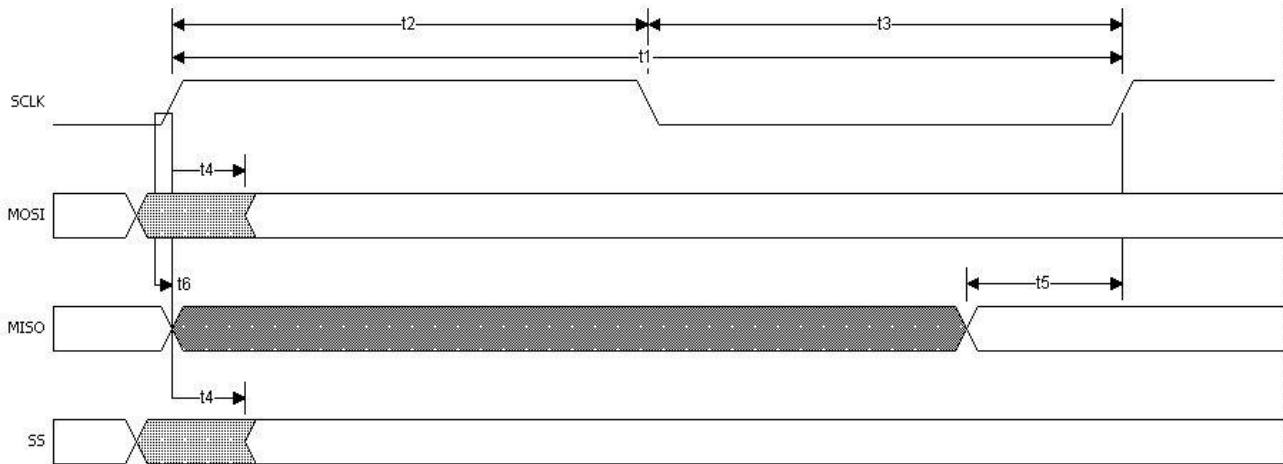

Figure 5-6 Typical SPI Master Timing

Time	Description	Minimum	Typical	Maximum	Unit
t1	SCLK period	39.68	41.67		ns
t2	SCLK high period	19.84	20.84	21.93	ns
t3	SCLK low period	19.84	20.84	21.93	ns
t4	SCLK driving edge to MOSI/SS	-1.5		3	ns
t5	MISO setup time to sample SCLK edge			6.5	ns
t6	MISO hold time from sample SCLK edge	0			ns

Table 5.6 SPI Master Timing

6 USB Error Detection

Pin 32 (IOBUS7) of the device is provided to indicate a problem has occurred with the USB connection. Typical errors include USB Device Not Supported, which would occur if the USB port was connected to a non-Android class device port e.g. the FT311D is not designed to host memory sticks or printers etc. USB Device Not Responding and Hub not supported would be reported also if connected to a hub. The signal states are as follows:

Pin state	Definition
Logic 0	Device connected to USB and functional
Logic 1	Device not connected
One 50ms logic 0 pulse	Device not responding. This pulse occurs at plug-in and then the signal returns to logic 1. This then repeats at a 1 second interval.
Two 50ms logic 0 pulses	Device not supported. These pulses occur at plug-in and then the signal returns to logic 1. This then repeats at a 1 second interval.
Three 50ms logic 0 pulses	Hub not supported. These pulses occur at plug-in and then the signal returns to logic 1. This then repeats at a 1 second interval.

Table 6.1 Error Detection

7 Absolute Maximum Ratings

The absolute maximum ratings for FT311D are shown in Table 7.1. These are in accordance with the Absolute Maximum Rating System (IEC 60134). Exceeding these may cause permanent damage to the device.

Parameter	Value	Unit
Storage Temperature	-65°C to 150°C	Degrees C
Floor Life (Out of Bag) At Factory Ambient (30°C / 60% Relative Humidity)	168 Hours (IPC/JEDEC J-STD-033A MSL Level 3 Compliant)*	Hours
Ambient Temperature (Power Applied)	-40°C to 85°C	Degrees C.
Vcc Supply Voltage	0 to +3.63	V
VCC_IO	0 to +3.63	V
VCC_PLL_IN	0 to + 1.98	V
DC Input Voltage - USBDP and USBDM	-0.5 to +(Vcc +0.5)	V
DC Input Voltage - High Impedance Bidirectional	-0.5 to +5.00	V
DC Input Voltage - All other Inputs	-0.5 to +(Vcc +0.5)	V
DC Output Current - Outputs	4	mA
DC Output Current - Low Impedance Bidirectional	4	mA

Table 7.1 Absolute Maximum Ratings

- * If devices are stored out of the packaging beyond this time limit the devices should be baked before use. The devices should be ramped up to a temperature of 125°C and baked for up to 17 hours.

7.1 DC Characteristics

DC Characteristics (Ambient Temperature -40°C to +125°C)

Parameter	Description	Minimum	Typical	Maximum	Units	Conditions
Vcc1	VCC Operating Supply Voltage	2.97	3.3	3.63	V	

Vcc2	VCCIO Operating Supply Voltage	2.97	3.3	3.63	V	
VCC_PLL	VCC_PLL Operating Supply Voltage	1.62	1.8	1.98	V	
Icc1	Operating Supply Current 48MHz		25		mA	Normal Operation
Icc2	Operating Supply Current		128		μA	USB Suspend

Table 7.2 Operating Voltage and Current

Parameter	Description	Minimum	Typical	Maximum	Units	Conditions
Voh	Output Voltage High	2.4			V	I source = 8mA
Vol	Output Voltage Low			0.4	V	I sink = 8mA
Vin	Input Switching Threshold		1.5		V	

Table 7.3 I/O Pin Characteristics

Parameter	Description	Minimum	Typical	Maximum	Units	Conditions
UVoh	I/O Pins Static Output (High)	2.8			V	
UVol	I/O Pins Static Output (Low)			0.3	V	
UVse	Single Ended Rx Threshold	0.8		2.0	V	
UCom	Differential Common Mode	0.8		2.5	V	
UVdif	Differential Input Sensitivity	0.2			V	
UDrvZ	Driver Output Impedance	3	6	9	Ohms	

Table 7.4 USB I/O Pin (USB DP, USB DM) Characteristics

Parameter	Description	Minimum	Typical	Maximum	Units	Conditions
V _{CK}	Power supply of internal core cells and I/O to core interface	1.62	1.8	1.98	V	1.8V power supply
V _{CC18IO}	Power supply of 1.8V OSC pad	1.62	1.8	1.98	V	1.8V power supply
T _J	Operating junction temperature	-40	25	125	°C	
I _{in}	Input leakage current	-10	±1	10	μA	I _{in} = V _{CC18IO} or 0V
I _{oz}	Tri-state output leakage current	-10	±1	10	μA	

Table 7.5 Crystal Oscillator 1.8 Volts DC Characteristics

7.2 ESD and Latch-up Specifications

Description	Specification
Human Body Mode (HBM)	± 2000V
Machine mode (MM)	± 200V
Charged Device Mode (CDM)	± 500V
Latch-up	> ± 200mA

Table 7.6 ESD and Latch-up Specifications

8 Application Examples

The following sections illustrate possible applications of the FT311D.

8.1 USB to GPIO Converter

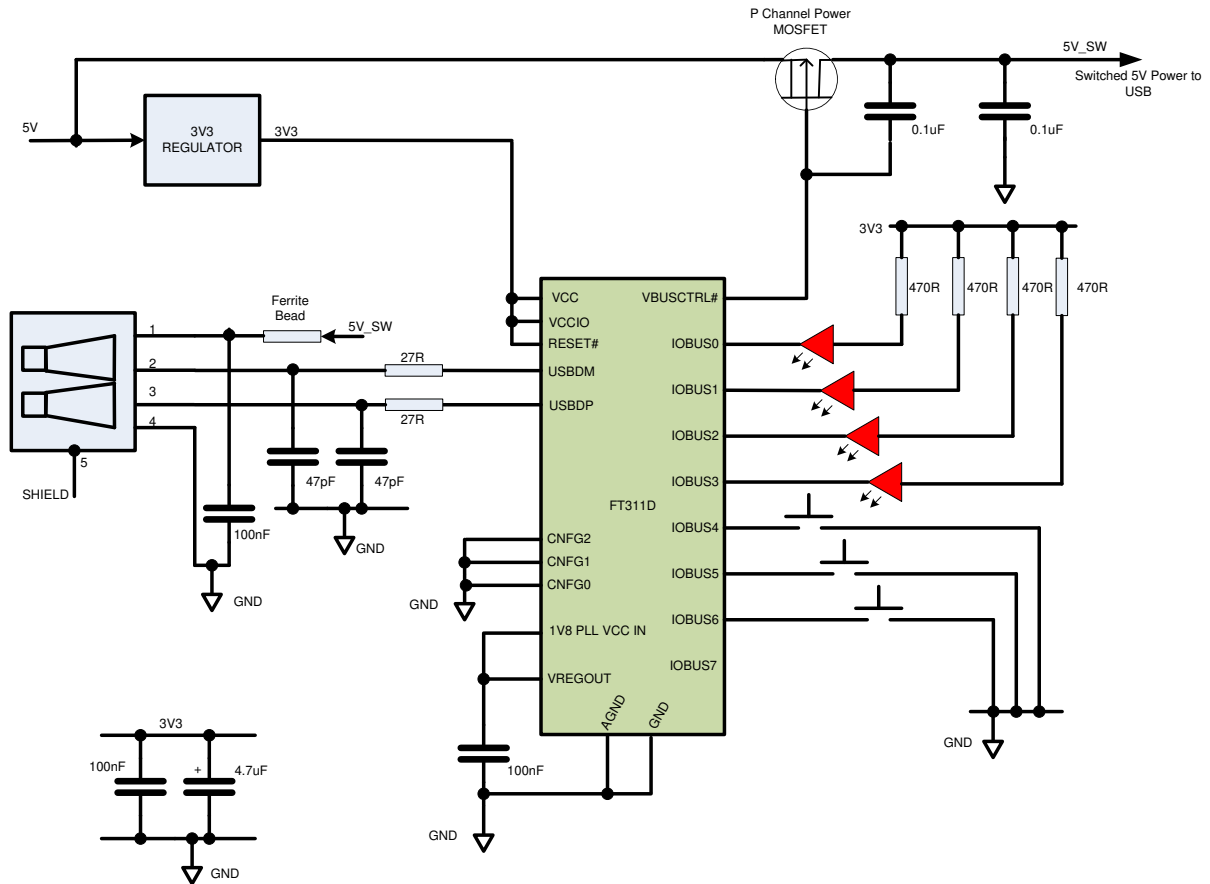

Figure 8.1 Application Example showing USB to GPIO Converter

This example shows the CNFGx pins set for mode 000 – GPIO.

IOBUS0-3 are configured as outputs by the Android application to control the LEDs.

IOBUS4-6 pins are configured as inputs to allow the buttons to control actions in the Android application.

Power to the USB port is enabled by the VBUSCTRL# signal

8.2 USB to UART Converter

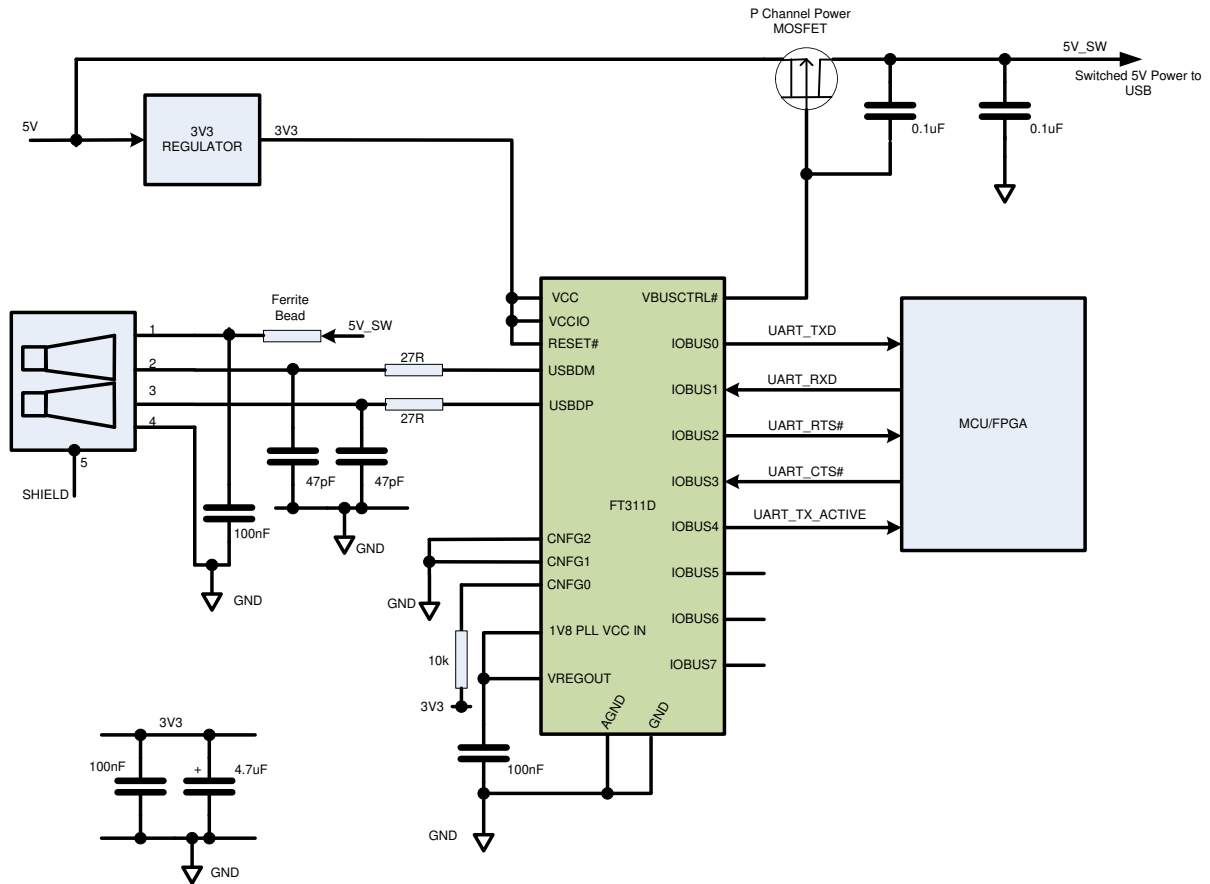

Figure 8.2 Application Example showing USB to UART Converter

This example shows the CNFGx pins set for mode 001 - UART.

The UART signals are at 3V3 level and may be used to drive directly into a FPGA or MCU with a 3V3 interface, or could be level shifted with an RS232, RS422 or RS485 transceiver. The UART_TX_ACTIVE signal is used mostly with RS485 transceivers to enable the transmit drivers.

The unused pins may be left unterminated.

Power to the USB port is enabled by the VBUSCTRL# signal

8.3 USB to PWM Converter

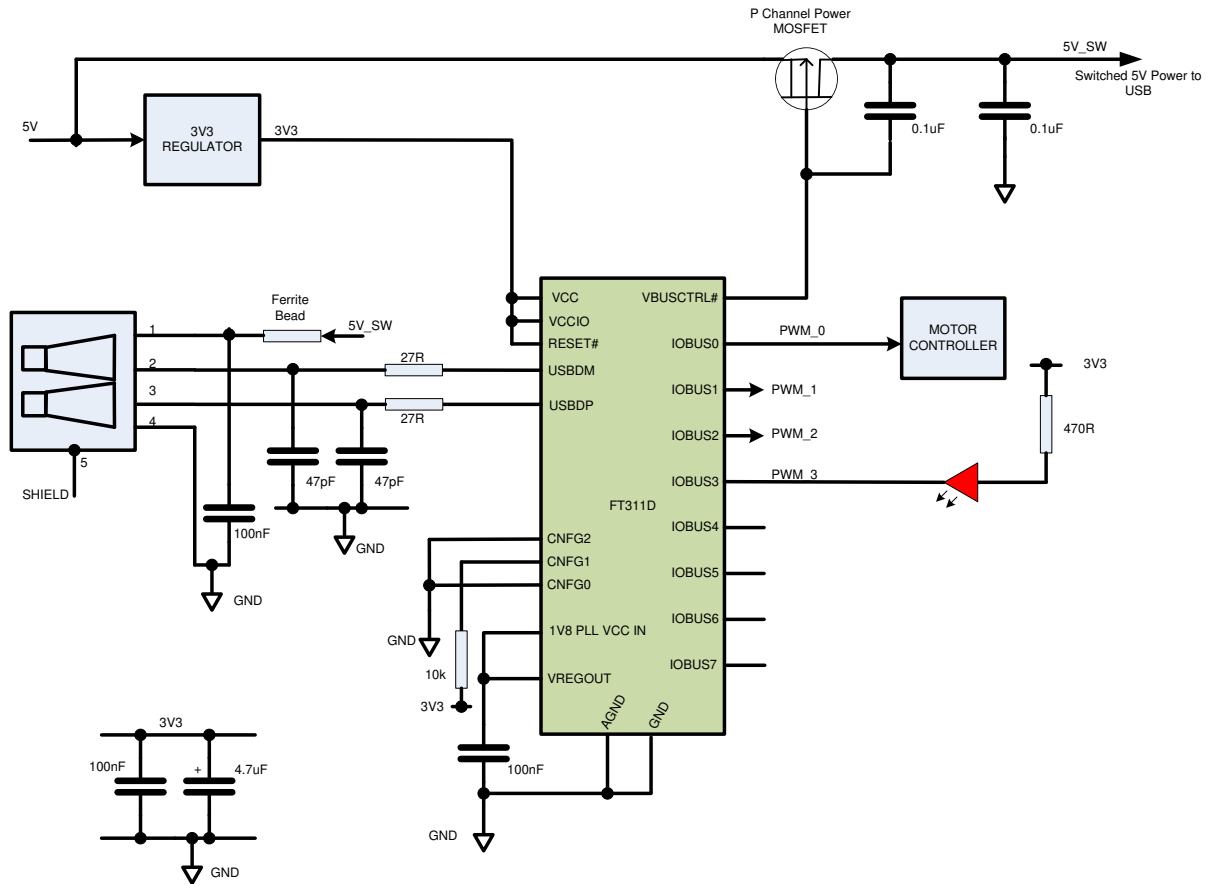

Figure 8.3 Application Example showing USB to PWM Converter

This example shows the CNFGx pins set for mode 010 – Pulse Width Modulation (PWM).

PWM channel 0 has been wired to a motor controller. This is typical of applications with robotic arms or moving machinery.

PWM channel 3 has been connected to an LED. This allows the LED to either flash or by altering the PWM switching frequency the controller can act as a “dimmer switch” to the LED.

The unused channels may be left unterminated.

Power to the USB port is enabled by the VBUSCTRL# signal