



Chipsmall Limited consists of a professional team with an average of over 10 year of expertise in the distribution of electronic components. Based in Hongkong, we have already established firm and mutual-benefit business relationships with customers from,Europe,America and south Asia,supplying obsolete and hard-to-find components to meet their specific needs.

With the principle of "Quality Parts,Customers Priority,Honest Operation,and Considerate Service",our business mainly focus on the distribution of electronic components. Line cards we deal with include Microchip,ALPS,ROHM,Xilinx,Pulse,ON,Everlight and Freescale. Main products comprise IC,Modules,Potentiometer,IC Socket,Relay,Connector.Our parts cover such applications as commercial,industrial, and automotives areas.

We are looking forward to setting up business relationship with you and hope to provide you with the best service and solution. Let us make a better world for our industry!



## Contact us

Tel: +86-755-8981 8866 Fax: +86-755-8427 6832

Email & Skype: info@chipsmall.com Web: www.chipsmall.com

Address: A1208, Overseas Decoration Building, #122 Zhenhua RD., Futian, Shenzhen, China



## FT825-12S480mA Design Report

|               |   |
|---------------|---|
| Title         | 18 Watts Isolated PSR LED Driver with High PF   |
| Specification | Input Voltage: 90~264Vac; 50/60Hz<br>Output Voltage: 40V_dc<br>Output Current: 480mA_dc |
| Application   | Power Driver for LED T8 Tube  |
| Author        | FMD Application Engineering Department  |
| Date          | 2012-10-22  |
| Reversion     | 2.0   |

### FEATURES

- Ultra-thin (less than 10mm) design;
  - The LED driver can be assembled at the back side of LED Display Boards, to get well-distributed LED light.
- Highly energy efficient
  - >87%@115Vac input; >88%@230Vac input
- High PF value
  - >0.93, 90~264Vac input
- Minimum BOM, PCB Size minimized, highly cost-competitive
  - Length of Printed Circuit Board is 216mm
- Integrated protection and reliability features
  - LED Open / Short-circuited Protection with auto recovery
  - Cycle by Cycle Current Limiting Protection
- No over-shoot for LED output current during start-up, high reliability and long lifetime.
- ON/OFF test passed ( Input 264Vac, 4S ON/ 4S OFF, endured 10000 times)
- Meets IEC 61000-4-5 Surge, IEC 61000-3-2 Class C harmonics requirements
- Meet EMI EN55015 B & FCC Part 18 Class B standard

**Contents**

|          |   |            |
|----------|---|------------|
| <b>1</b> | <b>Brief Introduction.....</b>  | <b>3</b>   |
| <b>2</b> | <b>Power Supply Specification.....</b>                                  | <b>4</b>   |
| <b>3</b> | <b>Circuit Diagram.....</b>   | <b>5</b>   |
| <b>4</b> | <b>PCB Layout .....</b>   | <b>6</b>   |
| <b>5</b> | <b>Bill of Materials.....</b>   | <b>7-8</b> |
| <b>6</b> | <b>Transformer Specification.....</b>                                   | <b>9</b>   |
| <b>7</b> | <b>Performance Test Data.....</b>                                       | <b>10</b>  |
| 7.1      | Input Voltage vs Output Current/ Power Factor/ THD/ Efficiency.....     | 10-12      |
| 7.2      | Output Voltage vs Output Current .....                                  | 13         |
| 7.3      | Temperature Rise.....   | 14         |
| <b>8</b> | <b>Key Waveforms .....</b>  | <b>15</b>  |
| 8.1      | Line Voltage and Current.....   | 15         |
| 8.2      | Power MOSFET Vds(p-p) and Ids(p-p) Under Working.....                   | 15         |
| 8.3      | Power MOSFET Vds(p-p) and Ids(p-p) At Start-up.....                     | 15         |
| 8.4      | Power MOSFET Vds(p-p) and Ids(p-p) While Output is Short-circuited..... | 16         |
| 8.5      | Output Voltage and Current with Full-load.....                          | 16         |
| 8.6      | Output Voltage and Current While Output is Short-circuited.....         | 16         |
| 8.7      | Output Voltage with No-Load (LED Open).....                             | 17         |
| 8.8      | Output Voltage and Current At Start-up.....                             | 17         |
| <b>9</b> | <b>EMI.....</b>   | <b>18</b>  |
| 9.1      | Conducted EMI Measurement.....  | 18-21      |
| 9.2      | Radiated EMI measurement.....   | 22-25      |

## 1 Brief Introduction

The FT825-12S480mA LED driver is an isolated PSR solution, utilizing Fly back topology that works in Boundary Conduction Mode (BCM) with Power Factor Correction (PFC) function. It works under universal AC voltage from 90V to 264V and provides output voltage 25~44Vdc & output current 0.48A for LED strings.

Few components are used in the FT825-12S480mA LED driver; it increases the power density and reduces the total material cost, in contrast to conventional single stage PFC solution with opto-coupler and secondary CC/CV circuit. Meanwhile, the PSR controller IC FT825 is combined with optimized system design, which guarantees the LED driver system working in BCM to enhance efficiency for the LED driver.

The design target is to keep the LED driver ultra-thin and highly energy efficient. It facilitates the assembly of the end products LED T8 Tubes while keeping the temperature rise of all components within an acceptable range.



Figure 1. PCB Assembly (Top View)



Figure 2. PCBA Assembly (Bottom View)



Figure 3. PCBA Height (<10mm)

## 2 Power Supply Specification

The table below represents the minimum acceptable performance of the design.  
Actual performance is listed in the results section.

| Description  | Symbol   | Min.  | Typical            | Max.      | Unit        | Remark   |
|--|--|---|--------------------|-----------|-------------|--|
| <b>Input</b><br>Voltage<br>Frequency   | V <sub>in</sub><br>f <sub>LINE</sub>                     | 90<br>47  | 115/230<br>50/60   | 264<br>64 | Vac<br>Hz   | 2 Wires, no P.E.<br>Class II Equipment                 |
| <b>Output</b><br>Output Voltage Output<br>Current Continuous<br>Output Power | V <sub>out</sub><br>I <sub>out</sub><br>P <sub>out</sub> | 25  | 40<br>0.48<br>19.2 | 42        | V<br>A<br>W |  |
| <b>Efficiency</b><br>Full Load   | $\eta$   | 87  |                    |           | %           | Measured at<br>115/230Vac input                        |
| <b>Environmental</b><br>Conducted EMI<br>Radiated EMI<br>Safety              |  | Meet CISPR 15B/EN55015B<br>FCC Part 15 Class B / EN55015<br>Meet IEC60950 |                    |           |             |  |
| Power Factor   |  | 0.93  |                    |           |             | Measured at 12S<br>480mA rating and<br>90~264Vac input |
| Total Harmonic Distortion  | THD  |   |                    | 20        | %           | Measured at 12S<br>480mA rating and<br>90~264Vac input |
| PCBA Dimension   |  | 216X17.5X10   |                    |           | mm          |  |
| Ambient Temperature  | T <sub>AMB</sub>   |   | 60                 |           | °C          | Natural Ventilation<br>Sea Level                       |

### 3 Circuit Diagram

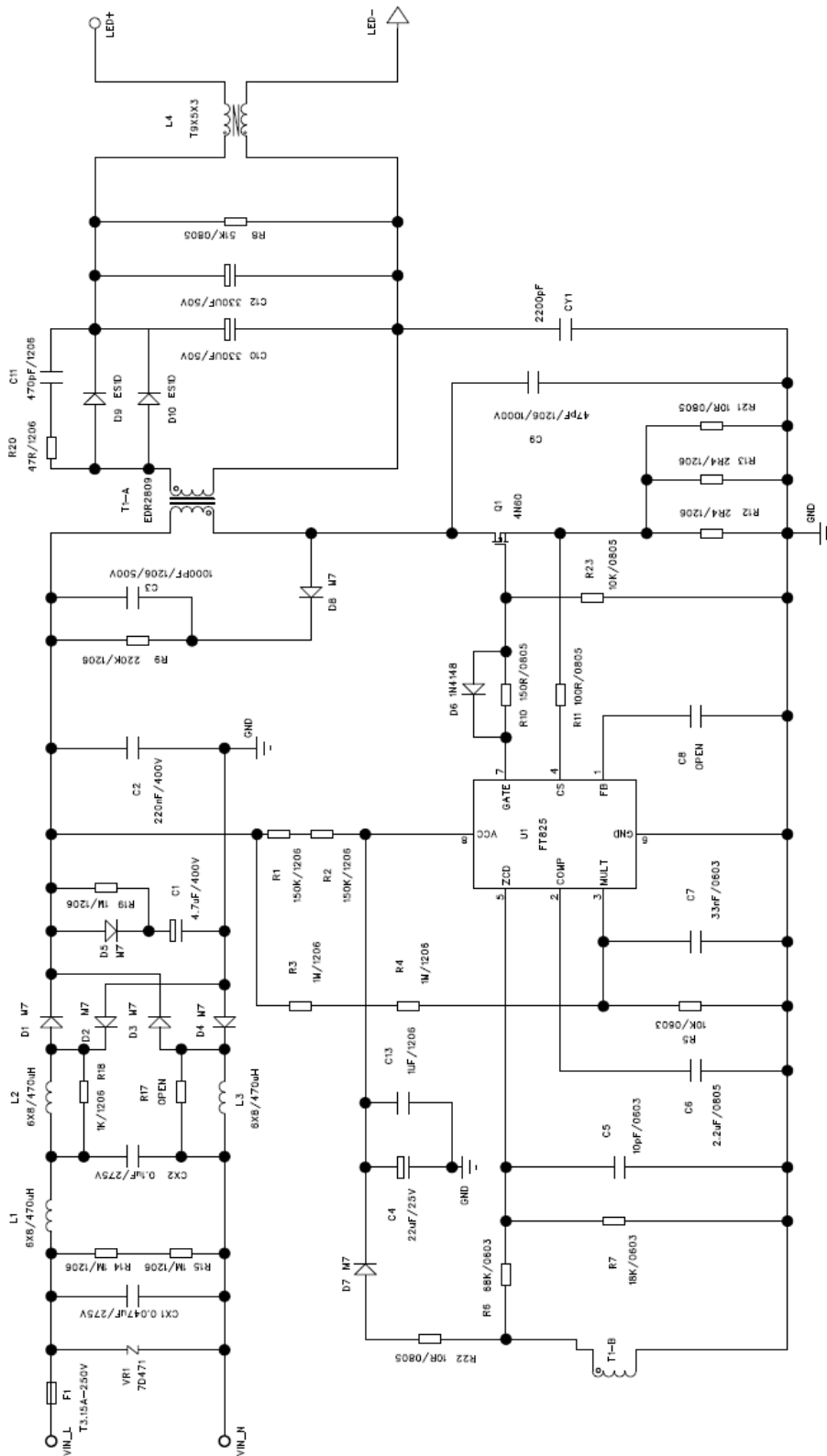


Figure 4. Circuit Diagram

#### 4 PCB Layout

- Double-sided PCB, Material FR-4; copper foil 10Z
- SMD and discrete components are assembled on the same Layer (Top View)



Figure 5. PCB Layout (Top View)

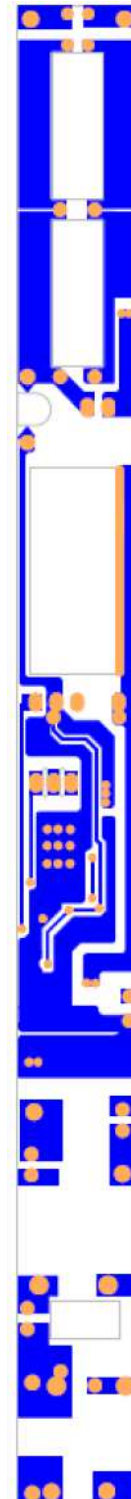
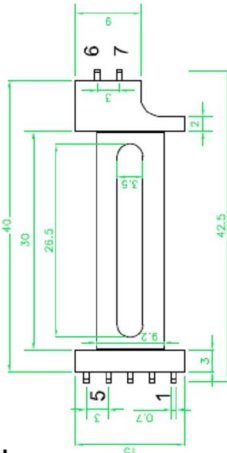


Figure 6. PCB Layout (Bottom View)

6 Transformer Specification

1. Dimension of Bobbin:

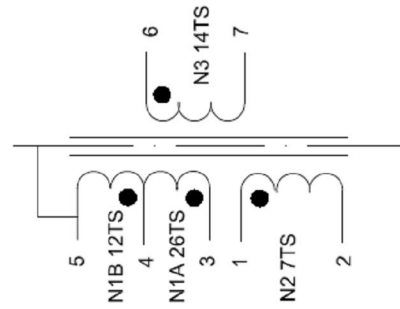
Bottom View:  
Unit: mm



2. Manufacturing Requirement:

- a. All windings shall be wound as per right Inner Windings Diagram.
- b. Transformer finish-goods shall be vacuummed before dipping varnish.
- c. Bobbin: EDR2809-7PIN.Ferrite Core: EDR2809,Material PC40 or equivalent ;
- d. Air gap is obtained by smashing center leg of cores.
- e. Pin 4 length shall be kept less than 1.2 mm after transformer finish-goods assembly.
- f. Having core connect to Pin 5 via one copper wire, then wrapped around the transformer with polymer tape.
- g. All units are mm.

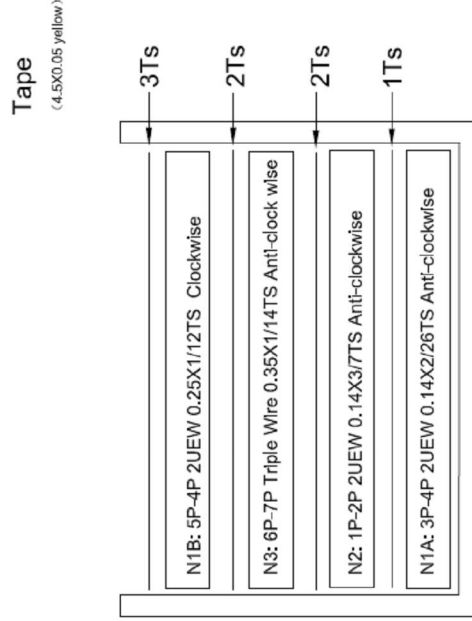
3. Winding Diagram



4. Electrical Specification:

- 1) L(N1 3P-5P)=670uH ± 7%(1KHz, 1V, SER)
- 2) HI-POT: N1 N2/N3:3.6KVAC 5mA 3Sec;
- 3) Leakage Inductance (5-3) : LN1<50uH (1KHz, 1V, SER), other windings shall be short(N2,N3)

5. Inner Windings Diagram



|                              |          |              |                    |
|------------------------------|----------|--------------|--------------------|
| TITLE: EDR2809-7Pin          | DRAWING  | Xiangbin.shu | DATE: Dec-24, 2012 |
| MODEL NO.: FT825-12S480mA-T1 | CHECKED  |              | DATE:              |
|                              | APPROVED |              | DATE:              |



## 7 Performance Test Data

All measurement data are obtained under ambient temperature.

### 7.1 Input Voltage/ Output Current/ PF/ THD/ Efficiency

| Vin (Vac) | Vout (V) | Vripple (V) | Iout (mA) | Iripple (mA) | PFC   | THD(%) | Iin(mA) | Pin(W) | Eff.(%) |
|-----------|----------|-------------|-----------|--------------|-------|--------|---------|--------|---------|
| 90        | 40       | 2.40        | 483       | 210          | 0.988 | 11.84  | 255.0   | 22.560 | 85.64   |
| 110       | 40       | 2.36        | 484       | 212          | 0.988 | 12.99  | 204.7   | 22.191 | 87.24   |
| 130       | 40       | 2.36        | 485       | 208          | 0.987 | 13.73  | 171.7   | 21.997 | 88.19   |
| 150       | 40       | 2.32        | 485       | 208          | 0.987 | 14.15  | 147.9   | 21.895 | 88.60   |
| 170       | 40       | 2.32        | 485       | 206          | 0.986 | 14.78  | 130.3   | 21.840 | 88.83   |
| 190       | 40       | 2.32        | 485       | 204          | 0.983 | 15.59  | 116.9   | 21.841 | 88.82   |
| 210       | 40       | 2.32        | 484       | 202          | 0.978 | 16.24  | 106.7   | 21.876 | 88.50   |
| 230       | 40       | 2.32        | 485       | 204          | 0.971 | 16.85  | 98.5    | 21.955 | 88.36   |
| 250       | 40       | 2.32        | 485       | 202          | 0.960 | 17.35  | 92.0    | 22.075 | 87.88   |
| 264       | 40       | 2.28        | 486       | 200          | 0.953 | 17.70  | 88.4    | 22.179 | 87.65   |

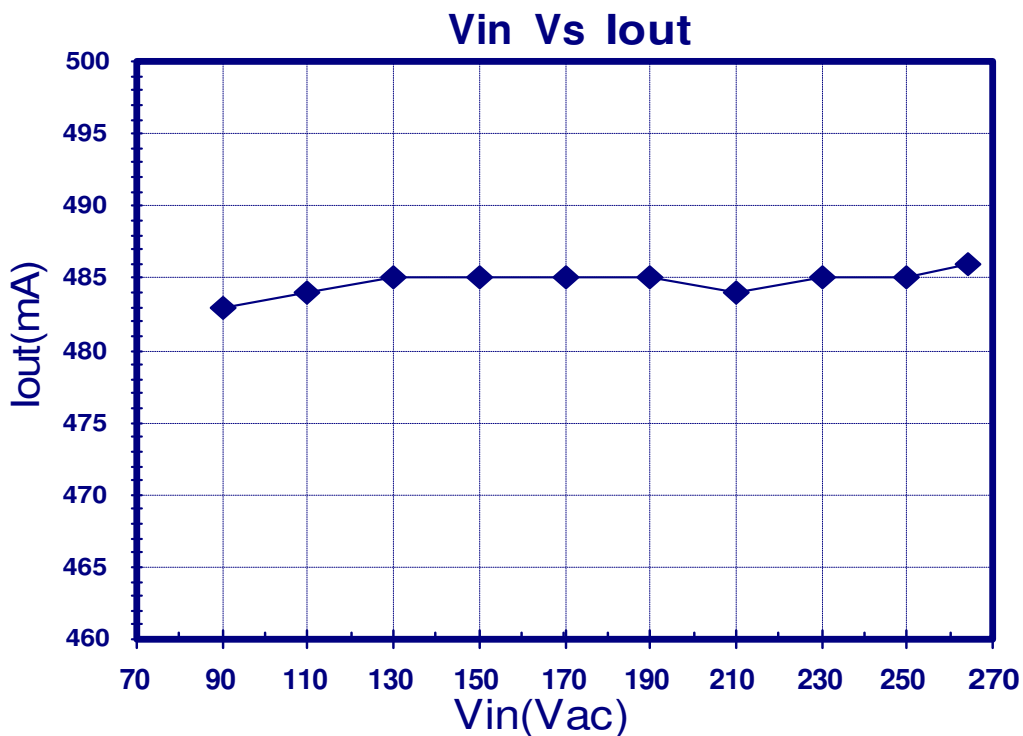


Figure 7. I<sub>o</sub> vs V<sub>in</sub>(ac) @ T<sub>a</sub>=25°C

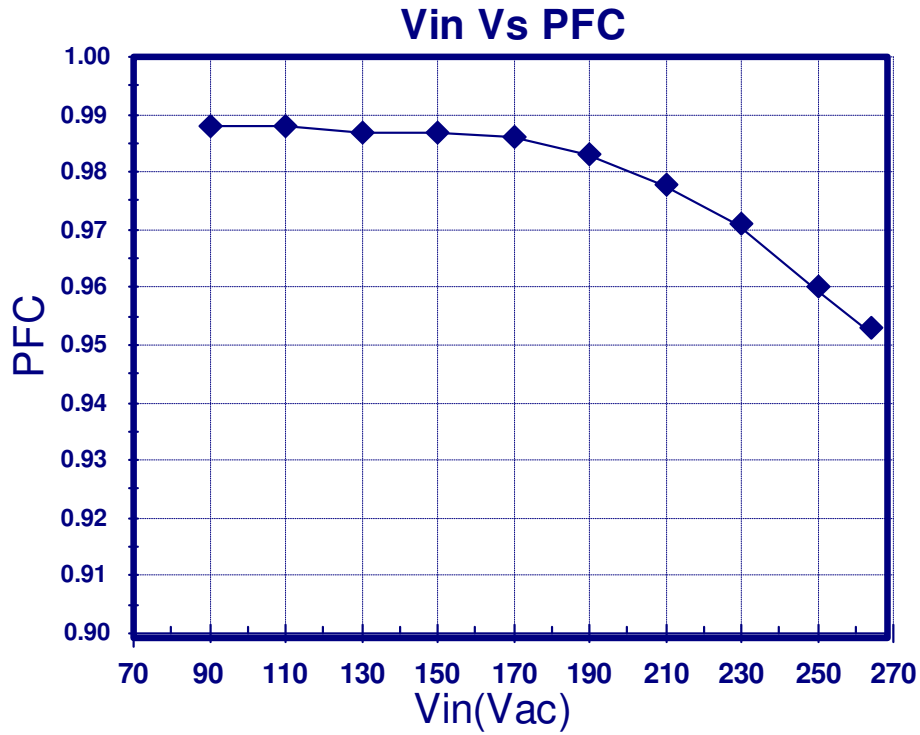


Figure 8. PF vs Vin(ac) @ Ta=25°C

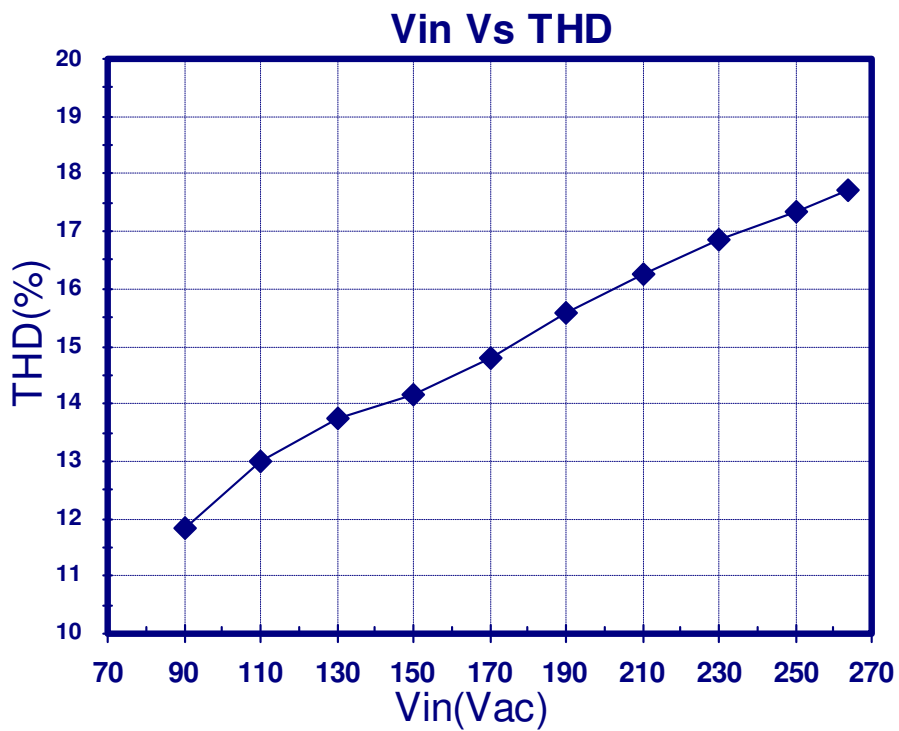


Figure 9. THD vs Vin(ac) @ Ta=25°C

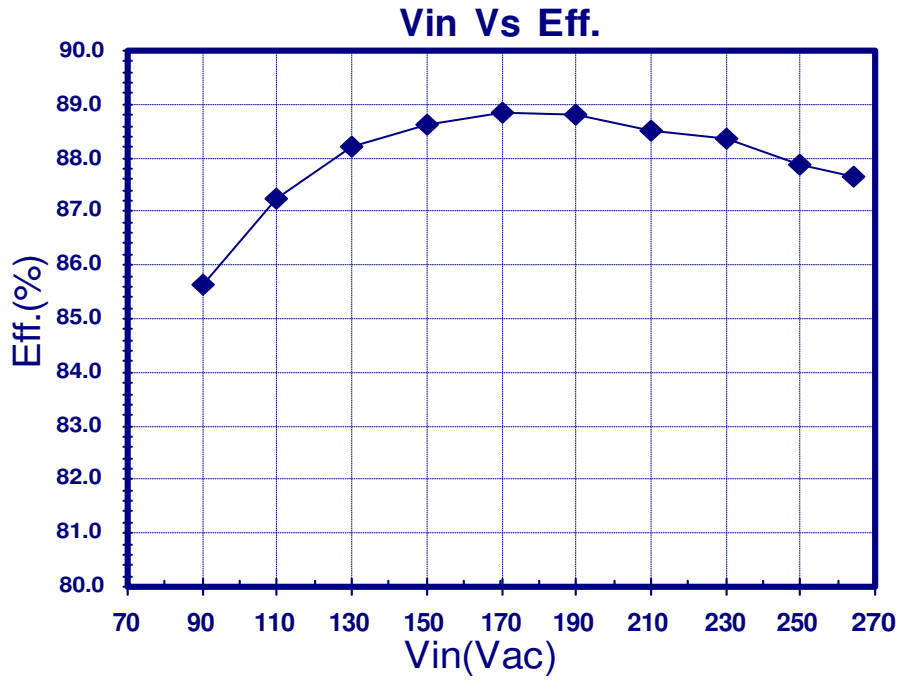


Figure 10. Efficiency vs Vin(ac) @ Ta=25°C

7.2 Output Voltage and Output Current

| Vin=90Vac |          | Vin=264Vac |          |
|-----------|----------|------------|----------|
| Vout(V)   | Iout(mA) | Vout(V)    | Iout(mA) |
| 50.2      | 0        | 50.3       | 0        |
| 46.0      | 481      | 46.0       | 483      |
| 45.0      | 481      | 45.0       | 483      |
| 42.0      | 482      | 42.0       | 485      |
| 40.0      | 483      | 40.0       | 486      |
| 35.0      | 484      | 35.0       | 491      |
| 30.0      | 487      | 30.0       | 495      |
| 25.0      | 491      | 25.0       | 500      |
| 20.0      | 494      | 20.0       | 504      |
| 19.5      | 495      | 19.5       | 504      |

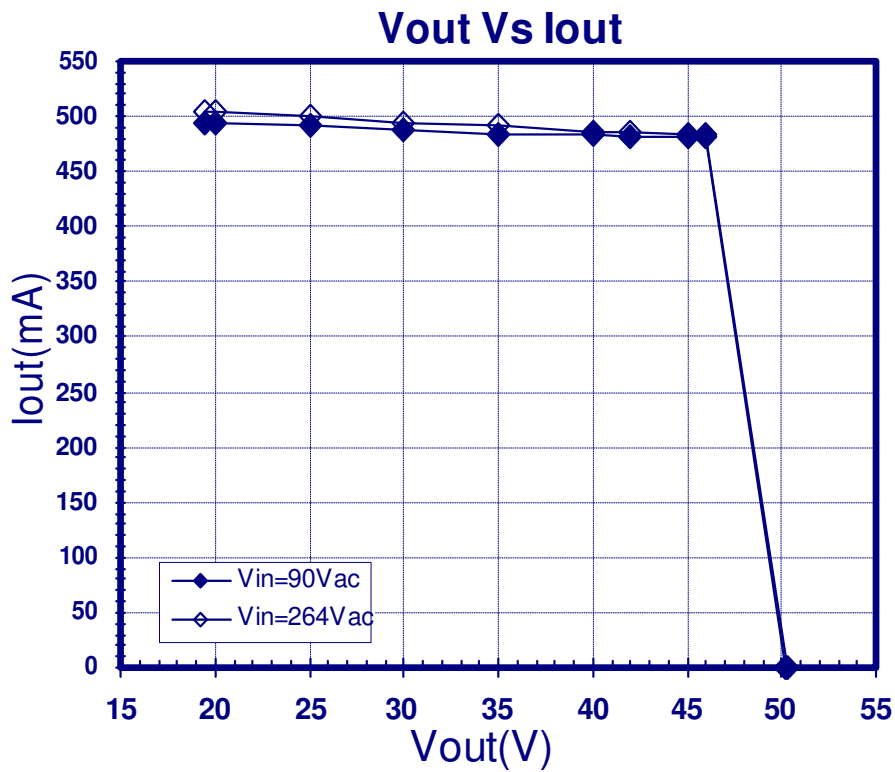


Figure 11. Iout vs Vout @ Ta=25°C

**7.3 Temperature Rise**

It is measured after EUT running 30minutes and under room temperature.

Test Conditions:

Vin=90Vac, Full-load

Vin=115Vac, Full-load

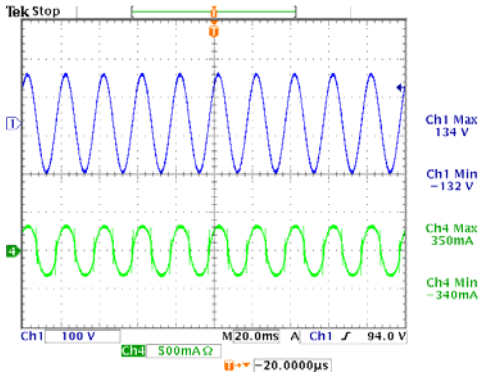
Vin=230Vac, Full-load

Vin=264Vac, Full-load

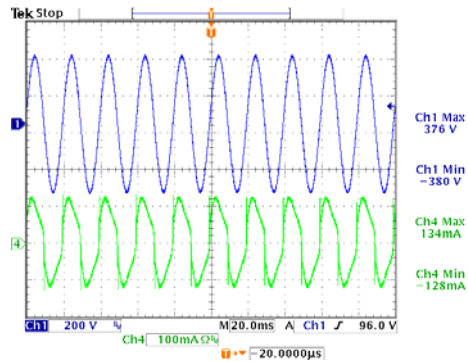
| Part        | Temperature (°C) |             |             |             | Temperature Rise (°C) |        |        |        |
|-------------|------------------|-------------|-------------|-------------|-----------------------|--------|--------|--------|
|             | 90Vac            | 115Vac      | 230Vac      | 264Vac      | 90Vac                 | 115Vac | 230Vac | 264Vac |
| <b>U1</b>   | 50.6             | 48.0        | 47.6        | 49.8        | 21.8                  | 19.4   | 18.8   | 21.3   |
| <b>Q1</b>   | 63.5             | 55.9        | 52.0        | 55.1        | 34.7                  | 27.3   | 23.2   | 26.6   |
| <b>T1-W</b> | 49.3             | 48.3        | 46.6        | 47.4        | 20.5                  | 19.7   | 17.8   | 18.9   |
| <b>T1-C</b> | 55.9             | 53.5        | 51.7        | 52.9        | 27.1                  | 24.9   | 22.9   | 24.4   |
| <b>D9</b>   | 52.3             | 52.5        | 55.5        | 56.6        | 23.5                  | 23.9   | 26.7   | 28.1   |
| <b>D10</b>  | 63.1             | 62.9        | 65.6        | 67.0        | 34.3                  | 34.3   | 36.8   | 38.5   |
| <b>C10</b>  | 39.9             | 40.4        | 42.1        | 42.9        | 11.1                  | 11.8   | 13.3   | 14.4   |
| <b>C12</b>  | 35.1             | 35.2        | 37.0        | 37.7        | 6.3                   | 6.6    | 8.2    | 9.2    |
| <b>D7</b>   | 61.8             | 58.0        | 55.5        | 58.0        | 33.0                  | 29.4   | 26.7   | 29.5   |
| <b>D8</b>   | 54.2             | 50.4        | 48.3        | 49.9        | 25.4                  | 21.8   | 19.5   | 21.4   |
| <b>Ta</b>   | <b>28.8</b>      | <b>28.6</b> | <b>28.8</b> | <b>28.5</b> | -                     | -      | -      | -      |

## 8 Key Waveforms

### 8.1 Line Voltage and Current

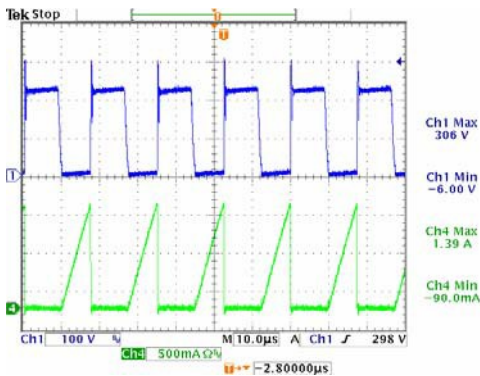


**Figure 12. 90Vac, Full load**  
Channel 1: Vin, 100V/Div  
Channel 4: Iin, 500mA/Div

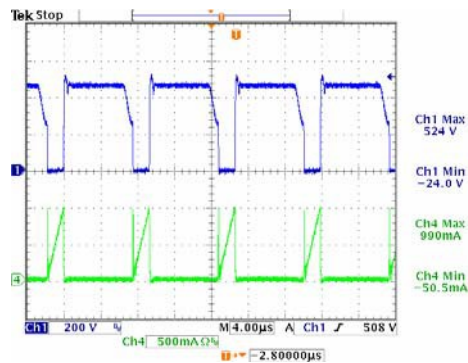


**Figure 13. 264Vac, Full load**  
Channel 1: Vin, 100V/Div  
Channel 4: Iin, 500mA/Div

### 8.2 Power MOSFET Vds(p-p) and Ids(p-p)

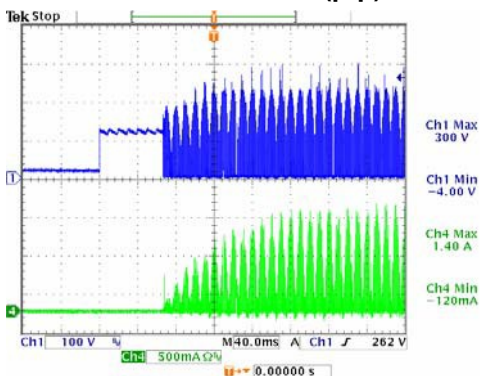


**Figure 14. 90Vac, Full load**  
Channel 1: Vds, 100V/Div  
Channel 4: Id, 500mA/Div

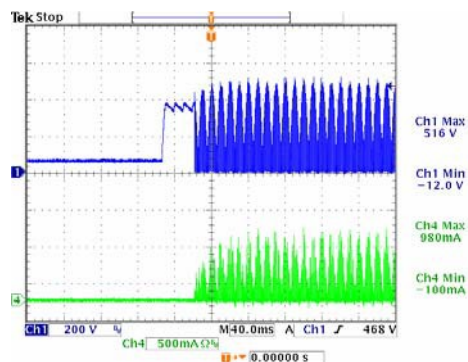


**Figure 15. 264Vac, Full load**  
Channel 1: Vds, 200V/Div  
Channel 4: Id, 500mA/Div

### 8.3 Power MOSFET Vds(p-p) and Ids(p-p) At Start-up

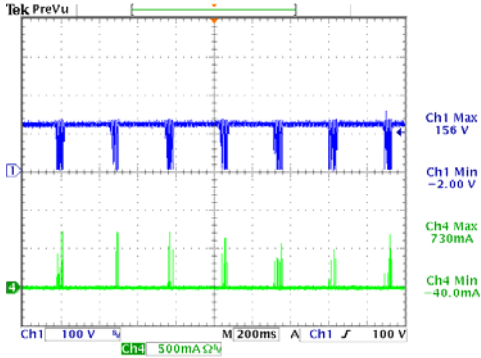


**Figure 16. 90Vac, Full load**  
Channel 1: Vds, 100V/Div  
Channel 4: Id, 500mA/Div

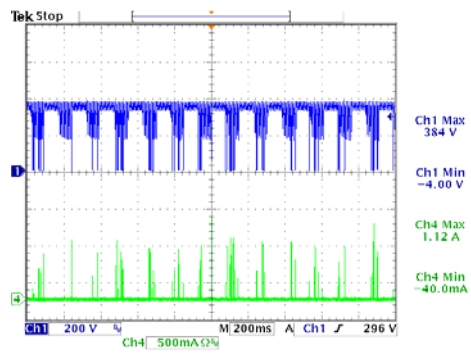


**Figure 17. 264Vac, Full load**  
Channel 1: Vds, 200V/Div  
Channel 4: Id, 500mA/Div

**8.4 Power MOSFET Vds(p-p) and Ids(p-p) While Output is Short-circuited**

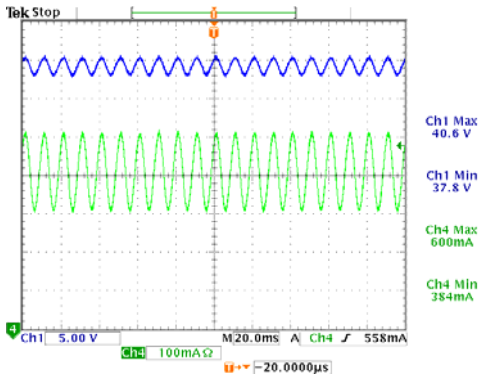


**Figure 18. 90Vac, Full load**  
Channel 1: Vds, 100V/Div  
Channel 4: Id, 500mA/Div

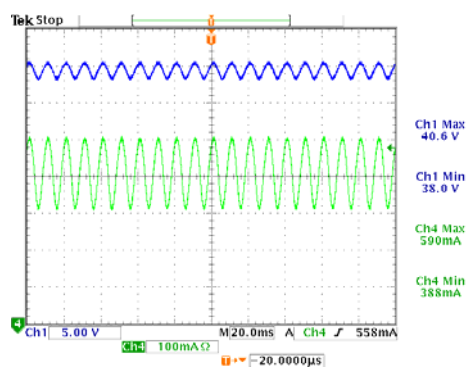


**Figure 19. 264Vac, Full load**  
Channel 1: Vds, 200V/Div  
Channel 4: Id, 500mA/Div

**8.5 Output Voltage and Current with Full-load**

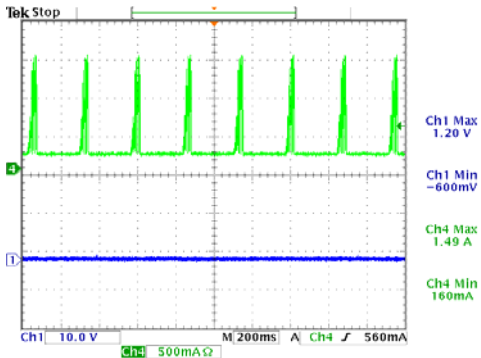


**Figure 20. 90Vac, Full load**  
Channel 1: Vout, 5V/Div  
Channel 4: Iout, 100mA/Div

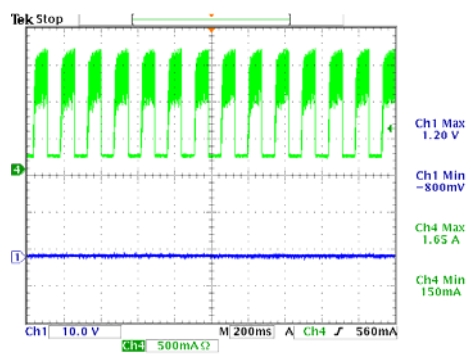


**Figure 21. 264Vac, Full load**  
Channel 1: Vout, 5V/Div  
Channel 4: Iout, 100mA/Div

**8.6 Output Voltage and Current While Output is Short-circuited**

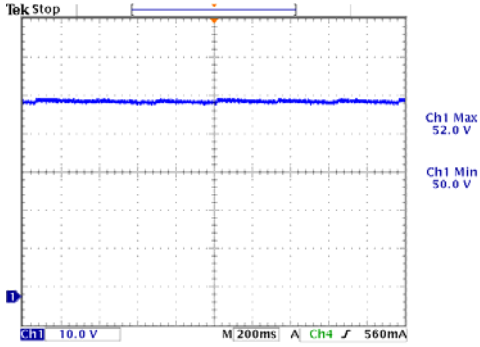


**Figure 22. 90Vac, Full load**  
Channel 1: Vout, 10V/Div  
Channel 4: Iout, 500mA/Div

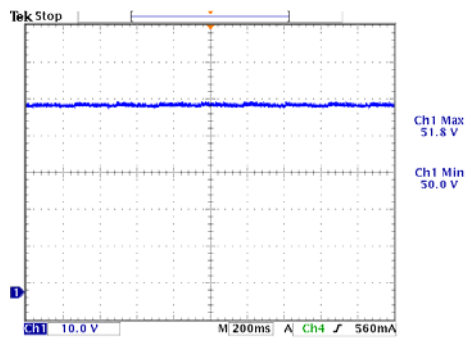


**Figure 23. 264Vac, Full load**  
Channel 1: Vout, 10V/Div  
Channel 4: Iout, 500mA/Div

**8.7 Output Voltage and Current with No-load (LED Open)**

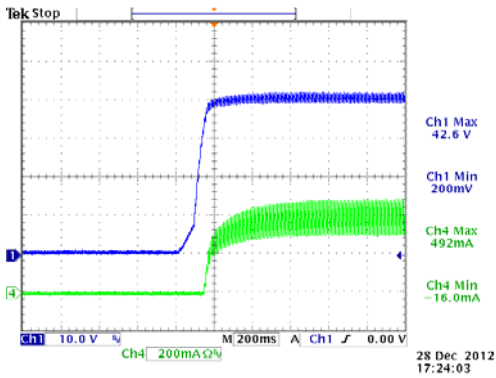


**Figure 24. 90Vac, No load**  
Channel 1: Vout, 10V/Div

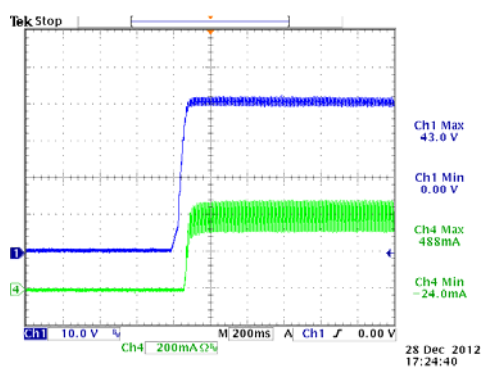


**Figure 25. 264Vac, No load**  
Channel 1: Vout, 10V/格

**8.8 Output Voltage and Current At Start-up**



**Figure 26. 90Vac, Full load**  
Channel 1: Vout, 10V/Div  
Channel 4: Iout, 200mA/Div



**Figure 27. 264Vac, Full load**  
Channel 1: Vout, 10V/Div  
Channel 4: Iout, 200mA/Div



**Fremont Micro Devices (SZ) Limited**

#5-8, 10/F, Changhong Building, Ke-Ji Nan 12 Road, Nanshan District, Shenzhen

Tel: (86 755) 86117811

Fax: (86 755) 86117810

**Fremont Micro Devices (Hong Kong) Limited**

#16, 16/F, Blk B, Veristrong Industrial Centre, 34-36 Au Pui Wan Street, Fotan, Shatin, Hong Kong

Tel: (852) 27811186

Fax: (852) 27811144

**Fremont Micro Devices (USA), Inc.**

42982 Osgood Road Fremont, CA 94539

Tel: (1-510) 668-1321

Fax: (1-510) 226-9918

Web Site: <http://www.fremontmicro.com/>

\* Information furnished is believed to be accurate and reliable. However, Fremont Micro Devices, Incorporated (BVI) assumes no responsibility for the consequences of use of such information or for any infringement of patents of other rights of third parties which may result from its use. No license is granted by implication or otherwise under any patent rights of Fremont Micro Devices, Incorporated (BVI). Specifications mentioned in this publication are subject to change without notice. This publication supersedes and replaces all information previously supplied. Fremont Micro Devices, Incorporated (BVI) products are not authorized for use as critical components in life support devices or systems without express written approval of Fremont Micro Devices, Incorporated (BVI). The FMD logo is a registered trademark of Fremont Micro Devices, Incorporated (BVI). All other names are the property of their respective owners.