



Chipsmall Limited consists of a professional team with an average of over 10 year of expertise in the distribution of electronic components. Based in Hongkong, we have already established firm and mutual-benefit business relationships with customers from,Europe,America and south Asia,supplying obsolete and hard-to-find components to meet their specific needs.

With the principle of “Quality Parts,Customers Priority,Honest Operation,and Considerate Service”,our business mainly focus on the distribution of electronic components. Line cards we deal with include Microchip,ALPS,ROHM,Xilinx,Pulse,ON,Everlight and Freescale. Main products comprise IC,Modules,Potentiometer,IC Socket,Relay,Connector.Our parts cover such applications as commercial,industrial, and automotives areas.

We are looking forward to setting up business relationship with you and hope to provide you with the best service and solution. Let us make a better world for our industry!



Contact us

Tel: +86-755-8981 8866 Fax: +86-755-8427 6832

Email & Skype: info@chipsmall.com Web: www.chipsmall.com

Address: A1208, Overseas Decoration Building, #122 Zhenhua RD., Futian, Shenzhen, China



- ⊕ REPRESENTS A CRITICAL DIMENSION.
- MAXIMUM CUT FLASH: .010 [0.25]
- MINIMUM PUSHOUT FORCE: 1 LB
- SHEAR TAILS TO DIMENSION SHOWN.
- MAXIMUM BURR: .003 [0.08]
- MAXIMUM COPLANARITY:
 - 05 THRU -49 = .004 [0.10]
 - 50 THRU -64 = .006 [0.15]
 - 65 THRU -90 = .009 [0.22]
- FOR -XX POSITION ASSEMBLY USE -XX POSITION BODY EXCEPT AS LISTED IN TABLE 2.
- IF -A CALLED OUT ON ASSEMBLY, USE -A ON END OF BODY CALLOUT. USE FTE-190-0X-G-DV-SA FOR STOCK THAT WILL BE CUT FOR STAKED -A ORDERS. USE FTE-190-0X-G-DV FOR ORDERS NOT REQUIRING STAKED -A OPTION.
- MAXIMUM ATTACHED FLASH ALLOWED ON POST SIDE ONLY: .02 [0.5]
- DURING CUT PROCESS, WALL MUST BE A MINIMUM OF .004" OR COMPLETELY REMOVED.
- IF RETENTION IS BELOW SPECIFICATION, A SUBSTITUTION OF FTE-90-D FOR FTE-90-D-A IS ACCEPTABLE.

FTE-1XX-XX-X-DV-XX-XX

No OF POSITIONS

-05 THRU -90
(PER ROW)

LEAD STYLE

- 01: .075 POST
(USE T-1S29-04-X-2 FOR HAND FILL,
T-1S29-02-X-2 FOR MACHINE FILL).
- 02: .175 POST
(USE T-1S29-04-X-2 FOR HAND FILL,
T-1S29-02-X-2 FOR MACHINE FILL).
- 03: .120 POST
(USE T-1S29-04-X-2 FOR HAND FILL,
T-1S29-02-X-2 FOR MACHINE FILL).

PLATING SPEC

-G: 10μ" GOLD IN CONTACT AREA,
3μ" GOLD ON TAIL

OPTIONS

- P: PICK AND PLACE PAD (SEE FIG 2, SHT 2)
(ONLY AVAILABLE FOR 08-90 POSITIONS)
(USE PPP-37)
(USE PPP-37-NT FOR TAPE & REEL)
- TR: TAPE & REEL PACKAGING
(USE PPP-37-NT ONLY)
- A: ALIGNMENT PIN (MOLDED OR STAKED)
[SAMTEC DISCRETION ON WHICH
-A PIN USED]
(MOLDED 4 POS MIN, SEE FIG 6, SHT 2)
(USE FTE-90-D-XX)
(STAKED 7 POS MIN, SEE FIG 5, SHT 2)
(USE FTE-90-D-A)
- M: METAL PICK & PLACE PAD
USE MPP-17-5 (SEE FIG 9 - SHT 3)
(10 POS MIN, AVAILABLE IN -01 STYLE ONLY)

FLEX SHROUD OPTIONS

- (STYLE -01 ONLY)
- ES: END SHROUD
(SAMTEC DISCRETION ON WHICH -ES USED)
(SEE FIG 3, SHT 2 FOR SNAPPED-ON,
11 POSITIONS MIN)
(SEE FIG 8, SHT 2 FOR MOLDED,
5 POSITIONS PER ROW MIN, SEE TABLE 2)
- EC: END SHROUD WITH LOCKING CLIPS
(SEE FIG 7, SHT 2)
(11 POSITIONS MIN)
- EP: END SHROUD WITH GUIDE POSTS
(SEE FIG 4, SHT 2)
(11 POSITIONS MIN)

ROW SPECIFICATION

-DV: DOUBLE ROW VERTICAL
(USE FTE-90-D-A)

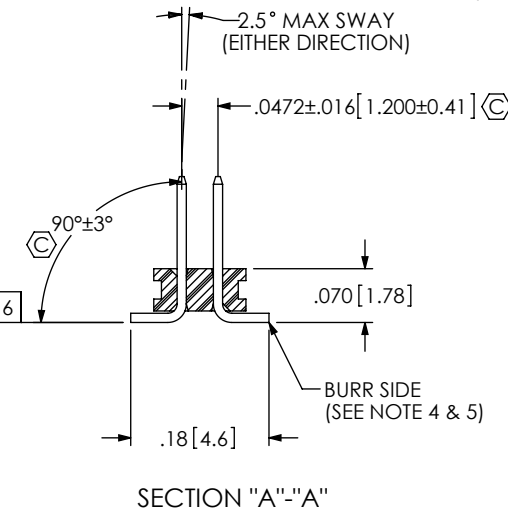
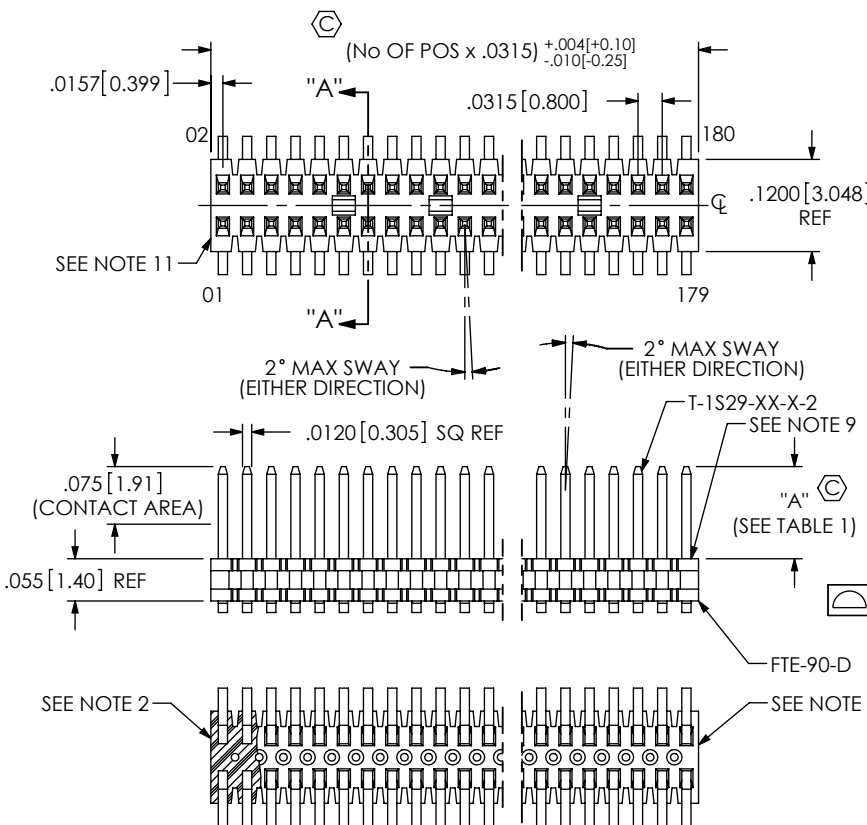

LEAD STYLE	"A"
-01	.075
-02	.175
-03	.120

ASSEMBLY	BODY
FTE-1XX-01-G-DV-ES-XX (SEE NOTE 7 AND 8)	FTE-90-D-ES-XX-X (SEE NOTE 7 AND 8)
FTE-115-01-G-DV-ES-XX (SEE NOTE 8)	FTE-85-D-ES-15-X (SEE NOTE 8)
FTE-120-01-G-DV-ES-A-XX	FTE-85-D-ES-20-A
FTE-120-01-G-DV-ES-XX	* FTE-90-D-ES-20

UNLESS OTHERWISE SPECIFIED, DIMENSIONS ARE IN INCHES.
TOLERANCES ARE:
DECIMALS ANGLES
X: ±.1 [2.5]
.XX: ±.01 [0.3] 2°
.XXX: ±.005 [0.13]
.XXXX: ±.0020 [0.051]

PROPRIETARY NOTE
THIS DOCUMENT CONTAINS CONFIDENTIAL AND PROPRIETARY INFORMATION AND ALL DESIGN, MANUFACTURING, REPRODUCTION, USE, PATENT RIGHTS AND SALES RIGHTS ARE EXPRESSLY RESERVED BY SAMTEC, INC. THIS DOCUMENT SHALL NOT BE DISCLOSED, IN WHOLE OR PART, TO ANY UNAUTHORIZED PERSON OR ENTITY NOR REPRODUCED, TRANSFERRED OR INCORPORATED IN ANY OTHER PROJECT IN ANY MANNER WITHOUT THE EXPRESS WRITTEN CONSENT OF SAMTEC, INC.

MATERIAL: DO NOT SCALE DRAWING SHEET SCALE: 4:1
INSULATOR: BLACK, LCP, UL 94 VO
TERMINAL: PHOS BRONZE

F:\DWG\MISC\MKTG\FTE-1XX-XX-X-DV-XX-XX-MKT.SLDDRW



520 PARK EAST BLVD, NEW ALBANY, IN 47150
PHONE: 812-944-6733 FAX: 812-948-5047
e-Mail: info@SAMTEC.com code 53322

DESCRIPTION:
.8MM x 1.2MM C.L. TERMINAL STRIP ASSM.
DWG. NO. **FTE-1XX-XX-X-DV-XX-XX**
BY: DEAN P 9/01/2009 SHEET 1 OF 3

REVISION BF

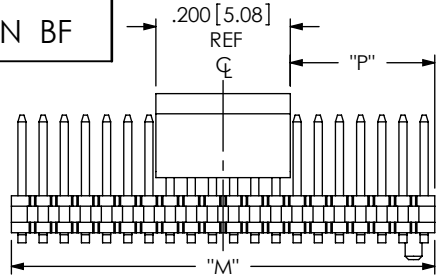

FIG 2
-P OPTION

(DIFFERENT AS SHOWN, OTHERWISE SAME AS FIG 1)

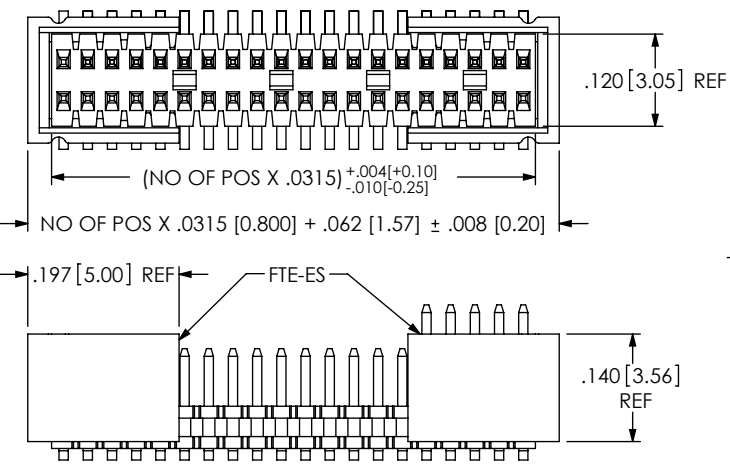
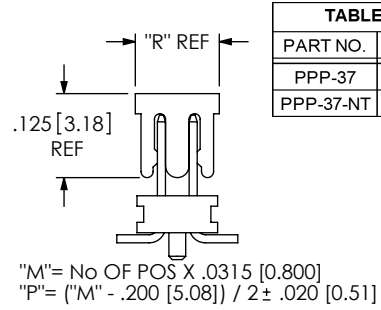

FIG 3

-ES OPTION (SNAPPED ON) (11 POS MIN)
(DIFFERENT AS SHOWN, OTHERWISE SAME AS FIG 1)

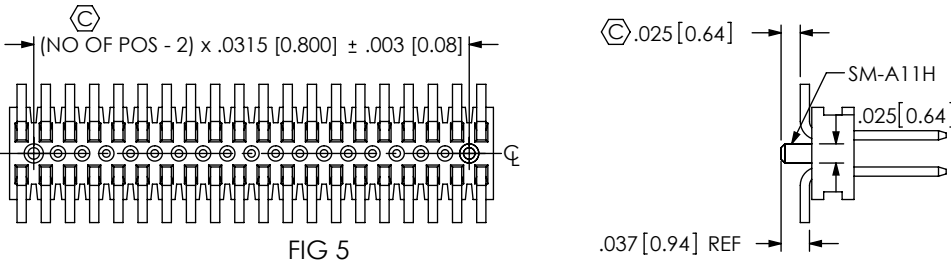

FIG 5

-A OPTION (STAKED) (7 POS MIN)
(DIFFERENT AS SHOWN OTHERWISE SAME AS FIG 1)

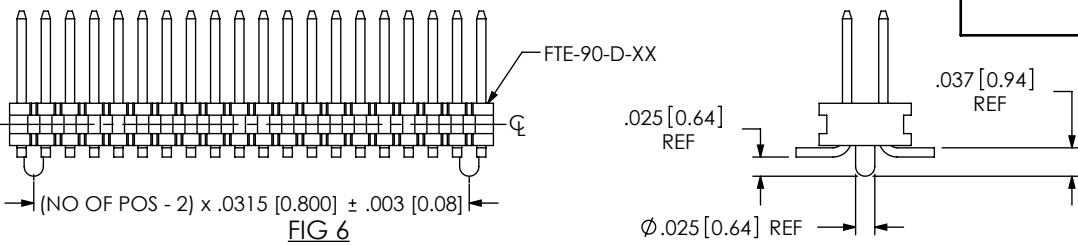

FIG 6

-A OPTION (MOLDED) (4 POS MIN)
(DIFFERENT AS SHOWN OTHERWISE SAME AS FIG 1)

TABLE 3	
PART NO.	"R"
PPP-37	.125
PPP-37-NT	.190

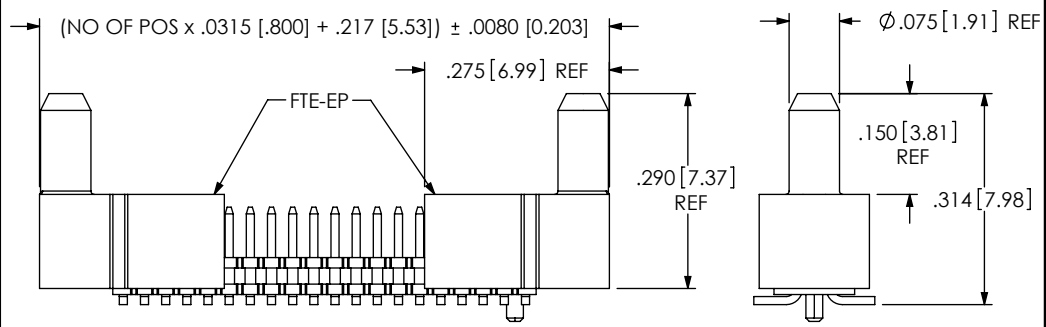

FIG 4
-EP OPTION

(DIFFERENT AS SHOWN, OTHERWISE SAME AS FIG 1)

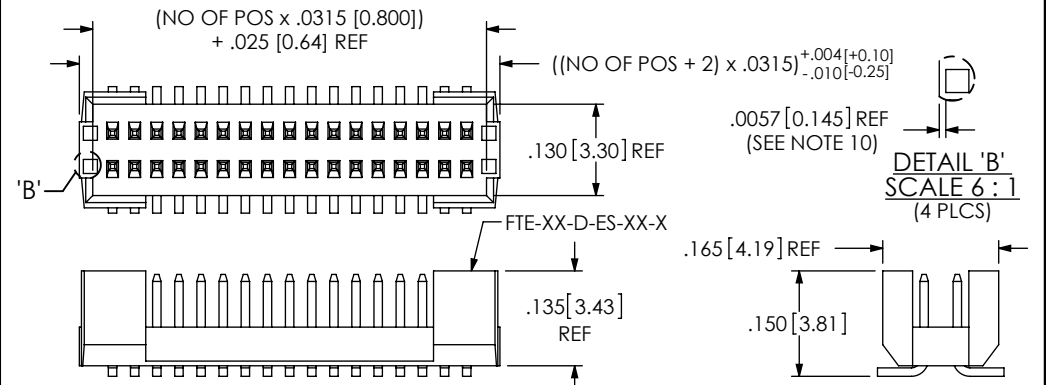

FIG 8

-ES OPTION (MOLDED) (5 POS MIN)
(DIFFERENT AS SHOWN, OTHERWISE SAME AS FIG 1)

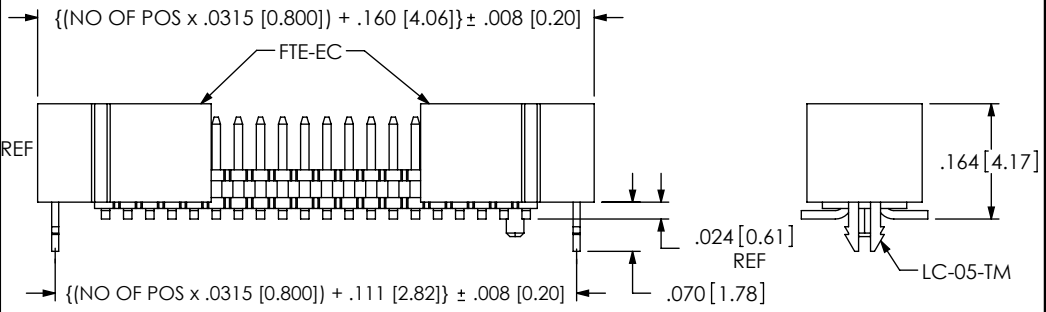

FIG 7

-EC OPTION
(DIFFERENT AS SHOWN, OTHERWISE SAME AS FIG 1)

PROPRIETARY NOTE
THIS DOCUMENT CONTAINS CONFIDENTIAL AND PROPRIETARY INFORMATION AND ALL DESIGN, MANUFACTURING, REPRODUCTION, USE, PATENT RIGHTS AND SALES RIGHTS ARE EXPRESSLY RESERVED BY SAMTEC, INC. THIS DOCUMENT SHALL NOT BE DISCLOSED, IN WHOLE OR PART, TO ANY UNAUTHORIZED PERSON OR ENTITY NOR REPRODUCED, TRANSFERRED OR INCORPORATED IN ANY OTHER PROJECT IN ANY MANNER WITHOUT THE EXPRESS WRITTEN CONSENT OF SAMTEC, INC.

DO NOT SCALE DRAWING
SHEET SCALE: 4:1



520 PARK EAST BLVD. NEW ALBANY, IN 47150
PHONE: 812-944-6733 FAX: 812-948-5047
e-Mail info@SAMTEC.com code 55322

DESCRIPTION:
.8MM x 1.2MM C.L. TERMINAL STRIP ASSM.

DWG. NO. FTE-1XX-XX-X-DV-XX-XX

BY: DEAN P 9/01/2009 SHEET 2 OF 3

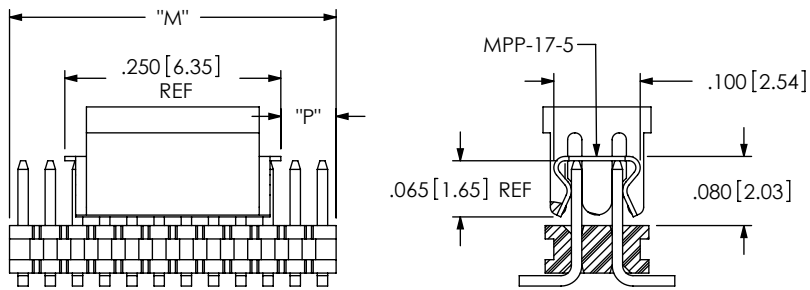

"M" = No OF POSITIONS x .0315 [0.800]

"P" = { ("M" - .250 [6.35]) / 2 } ±.020 [0.51]

FIG 9
-M OPTION
(DIFFERENT AS SHOWN, OTHERWISE SAME AS FIG 1)

PACKAGING TABLE

LEAD STYLE	OPTIONS	TUBE	PLUG
-01	NONE, -A	PT-FTE001-DV-P	TP-09
-02	NONE, -A	PT-FTE001-DV-P	TP-09
-03	NONE, -A	PT-FTE001-DV-P	TP-09
-01	-EC, -EC-P -EC-M, -ES-P, -ES-M, -ES-A-P	PT-1-24-01-37	TP-24
-01	-EP, -EP-M, -EP-P	PT-1-24-01-09	TP-24
-01, -02, -03	-P, -A-P	PT-FTE001-DV-P	TP-09
-01	-M, -AM	PT-FTE001-DV-P	TP-09
-01	-ES-A, -ES	PT-1-24-13-09	TP-24

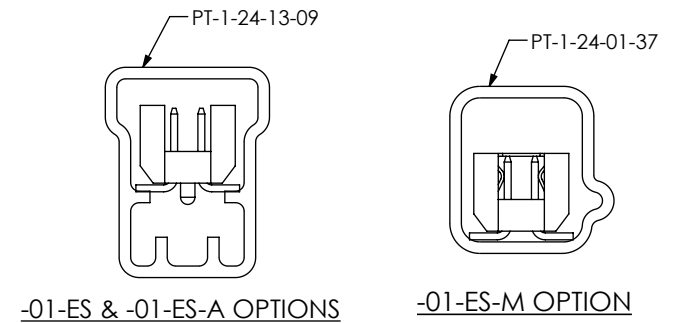
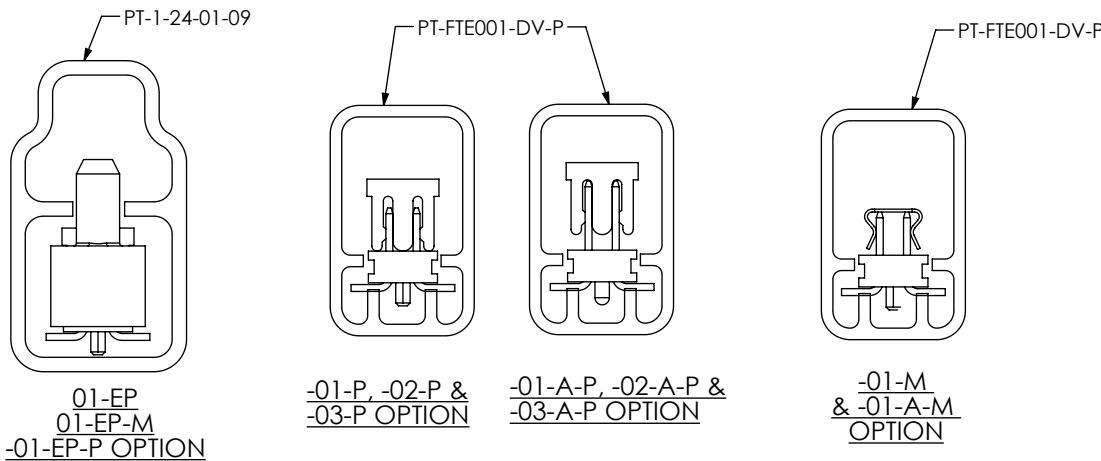
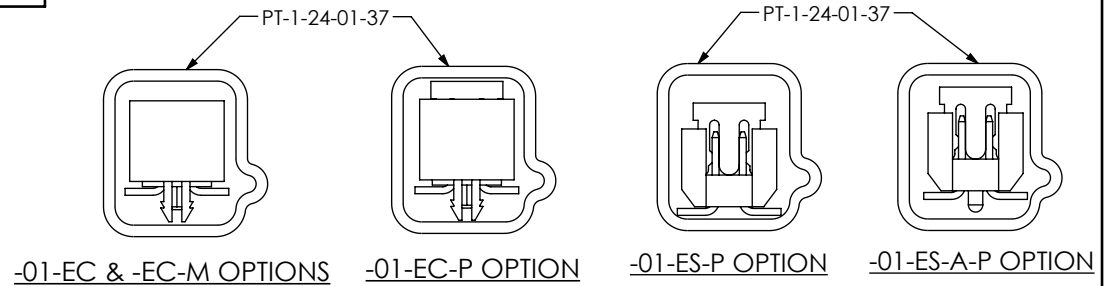
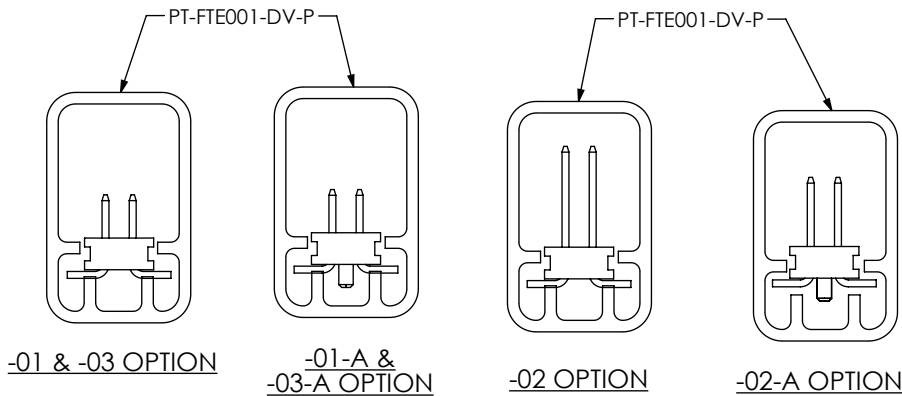

PROPRIETARY NOTE
THIS DOCUMENT CONTAINS CONFIDENTIAL AND PROPRIETARY INFORMATION AND ALL DESIGN, MANUFACTURING, REPRODUCTION, USE, PATENT RIGHTS AND SALES RIGHTS ARE EXPRESSLY RESERVED BY SAMTEC, INC. THIS DOCUMENT SHALL NOT BE DISCLOSED, IN WHOLE OR PART, TO ANY UNAUTHORIZED PERSON OR ENTITY NOR REPRODUCED, TRANSFERRED OR INCORPORATED IN ANY OTHER PROJECT IN ANY MANNER WITHOUT THE EXPRESS WRITTEN CONSENT OF SAMTEC, INC.

DO NOT SCALE DRAWING
SHEET SCALE: 4:1



520 PARK EAST BLVD, NEW ALBANY, IN 47150
PHONE: 812-944-6733 FAX: 812-948-5047
e-Mail info@SAMTEC.com code 55322

DESCRIPTION:
.8MM x 1.2MM C.L. TERMINAL STRIP ASSM.
DWG. NO. **FTE-1XX-XX-X-DV-XX-XX**

BY: DEAN P 9/01/2009 SHEET 3 OF 3