



Chipsmall Limited consists of a professional team with an average of over 10 year of expertise in the distribution of electronic components. Based in Hongkong, we have already established firm and mutual-benefit business relationships with customers from,Europe,America and south Asia,supplying obsolete and hard-to-find components to meet their specific needs.

With the principle of “Quality Parts,Customers Priority,Honest Operation,and Considerate Service”,our business mainly focus on the distribution of electronic components. Line cards we deal with include Microchip,ALPS,ROHM,Xilinx,Pulse,ON,Everlight and Freescale. Main products comprise IC,Modules,Potentiometer,IC Socket,Relay,Connector.Our parts cover such applications as commercial,industrial, and automotives areas.

We are looking forward to setting up business relationship with you and hope to provide you with the best service and solution. Let us make a better world for our industry!



Contact us

Tel: +86-755-8981 8866 Fax: +86-755-8427 6832

Email & Skype: info@chipsmall.com Web: www.chipsmall.com

Address: A1208, Overseas Decoration Building, #122 Zhenhua RD., Futian, Shenzhen, China



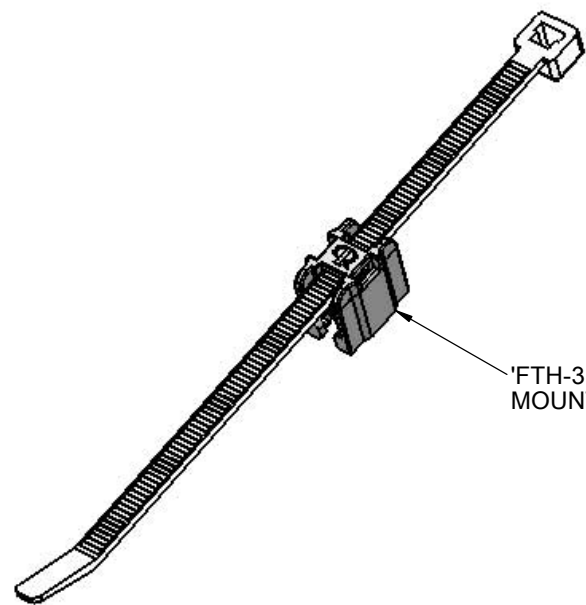

'FTH-31-01' WITH CABLE TIE MOUNTED ALONG PANEL

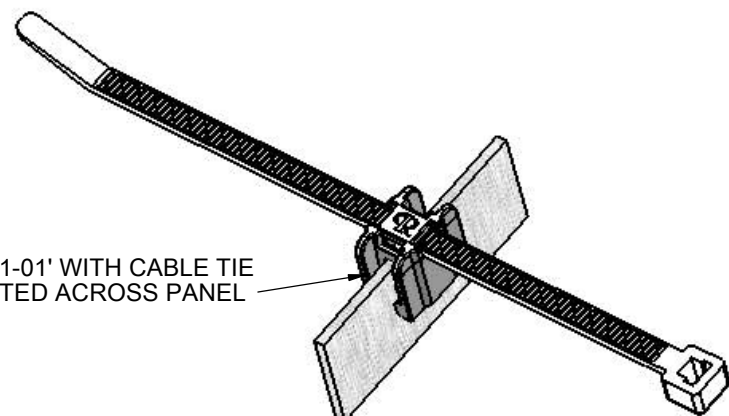

'FTH-31-01' WITH CABLE TIE MOUNTED ACROSS PANEL

MATERIAL: METAL CLIP: STAINLESS STEEL TYPE '2B' BRIGHT FINISH, (RMS-365) GRADE 304(1.4301 THICK), HOUSING: NYLON 6/6 UL94 V-2 (RMS-01)* COLOR: BLACK

PART NUMBER	PANEL THICKNESS	RETENTION FORCE	CABLE TIES ACCEPTED
FTH-31-01	0.8 - 3[.03 - .12]	TO STEEL PANEL: Minimum 25N 0.8 [0.03] Panel Minimum 45N 3 [0.12] Panel TO PLASTIC PANEL: Minimum 150N 2.4 - 3 [0.09 - 0.12]	WIT/WITA-30,-40,-50,

CAN BE ASSEMBLED WITH CABLE TIES BY SPECIAL ORDER

*HOUSING ALSO AVAILABLE IN NYLON 6/6 UL94 V-0 (RMS-19) AND NYLON 6/6 UL94 V-2 HEAT STABILIZED (RMS-47) BY SPECIAL ORDER. TO ORDER REPLACE -01 WITH -19 OR -47 RESPECTIVELY.

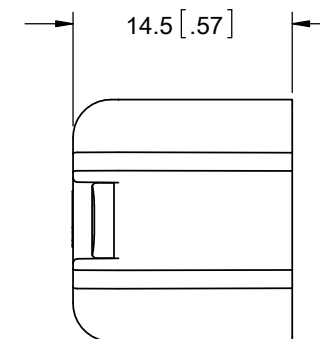
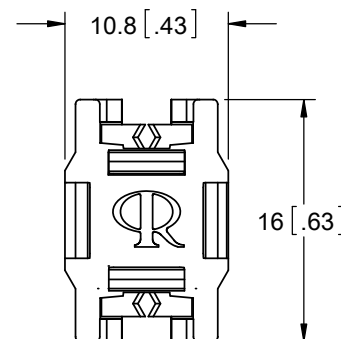
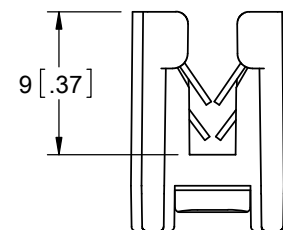

NOTES:
1. NOT SUPPLIED WITH CABLE TIES- TO BE ORDERED SEPARATELY

REV.	DESCRIPTION	ENGR.	DATE
A	RELEASED FOR PRODUCTION, CO 200654	SK	09/15/11

TITLE: EDGE CLIP TIE HOLDER							
CREATED USING SOLIDWORKS	FILE #: FTH-31	DWN: SK	APP: SK	FINAL			
TOLERANCES UNLESS NOTED ±0.25 ANG.=±1°	SHEET: 1 OF 1	SHEET SIZE: B	DT: 05/17/11	CHKD: DZ	PART #		PRINT TYPE
RE: RICHCO, INC		RICHCO, INC. WWW.RICHCO-INC.COM		SEE TABLE		CA	