



Chipsmall Limited consists of a professional team with an average of over 10 year of expertise in the distribution of electronic components. Based in Hongkong, we have already established firm and mutual-benefit business relationships with customers from,Europe,America and south Asia,supplying obsolete and hard-to-find components to meet their specific needs.

With the principle of “Quality Parts,Customers Priority,Honest Operation,and Considerate Service”,our business mainly focus on the distribution of electronic components. Line cards we deal with include Microchip,ALPS,ROHM,Xilinx,Pulse,ON,Everlight and Freescale. Main products comprise IC,Modules,Potentiometer,IC Socket,Relay,Connector.Our parts cover such applications as commercial,industrial, and automotives areas.

We are looking forward to setting up business relationship with you and hope to provide you with the best service and solution. Let us make a better world for our industry!



Contact us

Tel: +86-755-8981 8866 Fax: +86-755-8427 6832

Email & Skype: info@chipsmall.com Web: www.chipsmall.com

Address: A1208, Overseas Decoration Building, #122 Zhenhua RD., Futian, Shenzhen, China



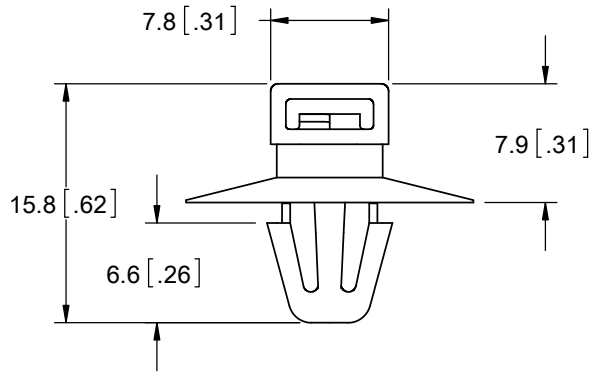
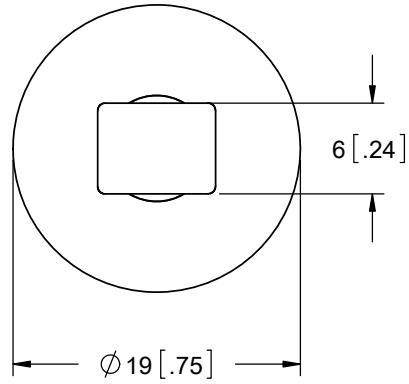
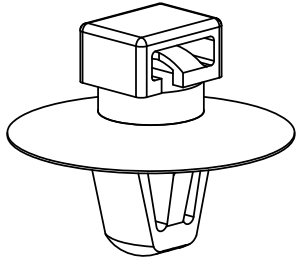

MATERIAL: NYLON 6/6 UL94 V-2 (RMS-01)

PART NUMBER	COLOR	PANEL HOLE ϕ	PANEL THICKNESS	CABLE TIE ACCEPTED
FTH-33-01	NATURAL	6.4[.251]	1.4 - 2[.055-.078]	WIT / WITA-40, -50

NOTES:

1. ALTERNATE UNITS FOR REFERENCE ONLY
2. OTHER COLORS AND MATERIALS AVAILABLE BY SPECIAL ORDER

TITLE: FLAT TIE HOLDER, CUPPED BASE					UNITS= mm [IN]	
CREATED USING SOLIDWORKS	FILE #: FTH-33	DWN: SK	APP: -	FINAL		
TOLERANCES UNLESS NOTED ± 0.25 ANG. $\pm 1^\circ$	SHEET: 1 OF 1	SHEET SIZE: A	DT: 05/17/11	CHKD: -	PART #	PRINT TYPE
A	RELEASED FOR PRODUCTION, CO 200654	SK	09/15/11	SEE TABLE		CA
REV.	DESCRIPTION	ENGR.	DATE	RICHCO, INC. WWW.RICHCO-INC.COM		