



Chipsmall Limited consists of a professional team with an average of over 10 year of expertise in the distribution of electronic components. Based in Hongkong, we have already established firm and mutual-benefit business relationships with customers from,Europe,America and south Asia,supplying obsolete and hard-to-find components to meet their specific needs.

With the principle of “Quality Parts,Customers Priority,Honest Operation,and Considerate Service”,our business mainly focus on the distribution of electronic components. Line cards we deal with include Microchip,ALPS,ROHM,Xilinx,Pulse,ON,Everlight and Freescale. Main products comprise IC,Modules,Potentiometer,IC Socket,Relay,Connector.Our parts cover such applications as commercial,industrial, and automotives areas.

We are looking forward to setting up business relationship with you and hope to provide you with the best service and solution. Let us make a better world for our industry!



Contact us

Tel: +86-755-8981 8866 Fax: +86-755-8427 6832

Email & Skype: info@chipsmall.com Web: www.chipsmall.com

Address: A1208, Overseas Decoration Building, #122 Zhenhua RD., Futian, Shenzhen, China



PART NO.	MATERIAL	COLOR	ADHESIVE
FTH-4-01	NYLON 6/6 (RMS-01)	NATURAL	NONE
FTH-4A-RT			ACRYLIC TAPE (RMS-15), WHITE LINER

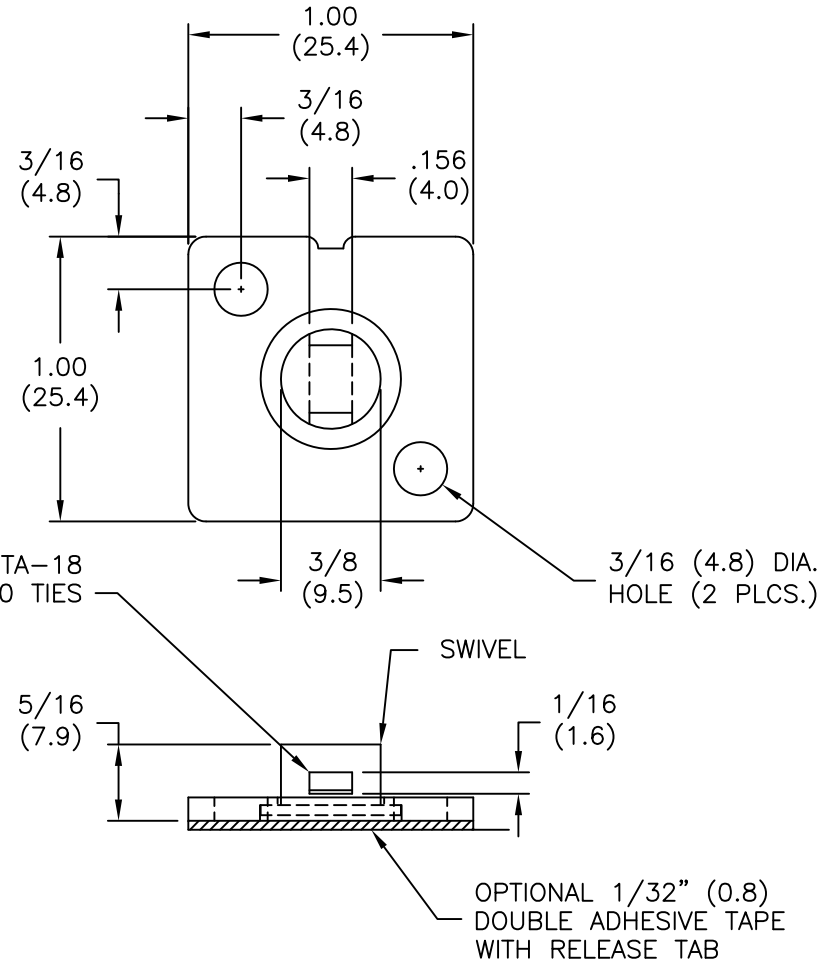

NOTES:

- UV STABILIZED NYLON 6/6, (RMS-46).
COLOR: BLACK,
ACRYLIC ADHESIVE TAPE (RMS-15), WHITE LINER,
AVAILABLE BY SPECIAL ORDER ONLY;
TO ORDER USE P/N FTH-4A-RT-UVB
OR FTH-4-UVB (WITHOUT TAPE).
- PACKAGING QUANTITIES ARE REFLECTED AS THE SUFFIX "-LETTER".
EXAMPLE: FTH-4-01-M FOR 1000 PCS.
-C = 100 PCS
-M = 1000 PCS

I	ADDED NOTE 2. SEE CO 200661	SK 05.12.11
H	SEE CO 200570 FOR CHANGES	SK 08.04.10
G	SEE ECN #1124 FOR CHANGES	SK 01.24.06
F	COMPLETELY RE-DRAWN & CHANGED FILE#	SM 10.18.01
E	REMOVED TABLE & CHANGED NOTE 3.	SM 01.31.01
D	DIM C UPDATED TO 5/16 (7.9)	MB. 9.18.00
C	RUBBER TAPE (RMS-102) ADDED	J.L. 8.22.00
B	MAT'L NOTES ADDED	J.L.1.4.00
A	CONVERTED TO ACAD	PB 06.29.94
REV	DESCRIPTION	ENGR DATE

TITLE: FLAT TIE HOLDER		DWG IN IN (MM)	FINAL	PRINT TYPE
FILE #	FTH-4	DWN: P.B.	APP:	CA
MAT'L:	SEE NOTES	DT: 06-29-94	DT:	
RE:	RICHCO, INC.	RICHCO INC. PO BOX 804238, CHICAGO, 60680 (773) 539-4060		
PART #		SEE TABLE		