



Chipsmall Limited consists of a professional team with an average of over 10 year of expertise in the distribution of electronic components. Based in Hongkong, we have already established firm and mutual-benefit business relationships with customers from,Europe,America and south Asia,supplying obsolete and hard-to-find components to meet their specific needs.

With the principle of "Quality Parts,Customers Priority,Honest Operation,and Considerate Service",our business mainly focus on the distribution of electronic components. Line cards we deal with include Microchip,ALPS,ROHM,Xilinx,Pulse,ON,Everlight and Freescale. Main products comprise IC,Modules,Potentiometer,IC Socket,Relay,Connector.Our parts cover such applications as commercial,industrial, and automotives areas.

We are looking forward to setting up business relationship with you and hope to provide you with the best service and solution. Let us make a better world for our industry!



Contact us

Tel: +86-755-8981 8866 Fax: +86-755-8427 6832

Email & Skype: info@chipsmall.com Web: www.chipsmall.com

Address: A1208, Overseas Decoration Building, #122 Zhenhua RD., Futian, Shenzhen, China



PART NO.	MATERIAL	COLOR	ADHESIVE
FTH-5-01	UL94 V-2 NYLON 6/6 (RMS-01)	NATURAL	NONE
FTH-5A-RT			1/32" THICK ACRYLIC TAPE (RMS-15), WHITE LINER W/ RELEASE TAB
FTH-5A1-RT			1/32" THICK RUBBER TAPE (RMS-102), BLUE LINER W/ RELEASE TAB
FTH-5-DHB			.04" THICK HIGH BOND ACRYLIC TAPE (RMS-500), RED LINER, NO RELEASE TAB
FTH-5-UVB	UVB STABILIZED NYLON (RMS-46)	BLACK	NONE
FTH-5A-RT-UVB			1/32" THICK ACRYLIC TAPE (RMS-15), WHITE LINER WITH RELEASE TAB
*FTH-5A1-RT-UVB			1/32" THICK RUBBER TAPE (RMS-102), BLUE LINER WITH RELEASE TAB

*AVAILABLE BY SPECIAL ORDER ONLY

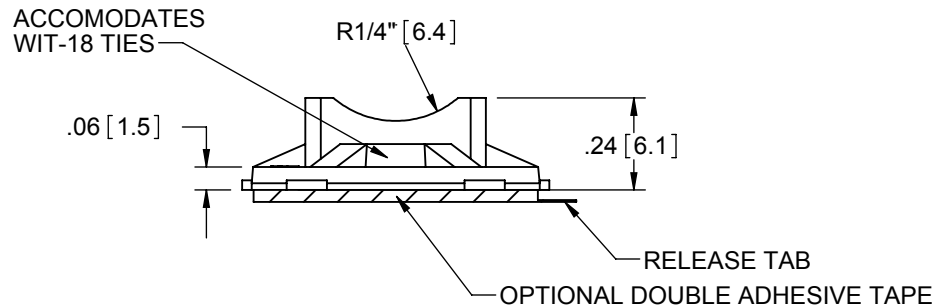
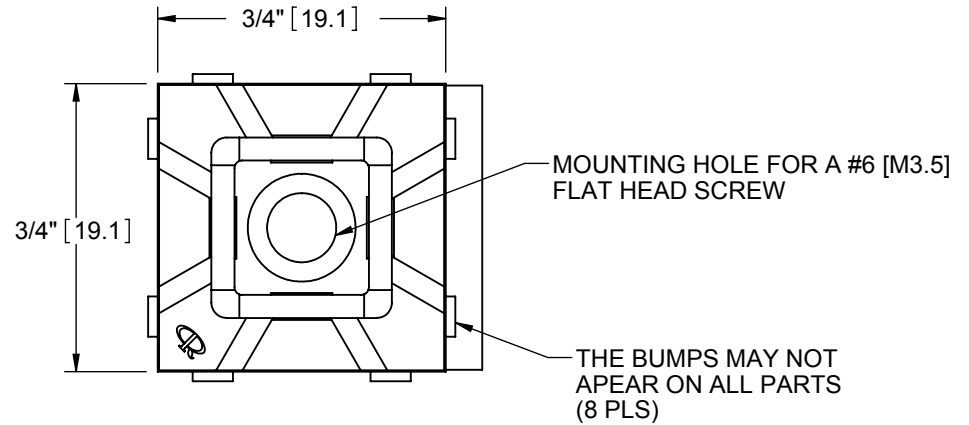
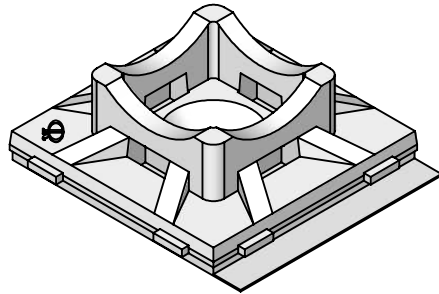

NOTES:
 1. UL94 V-0 NYLON 6/6 (RMS-19) MATERIAL AVAILABLE BY SPECIAL ORDER ONLY
 COLOR NATURAL.
 2. PACKAGING QUANTITIES ARE REFLECTED AS THE SUFFIX "-LETTER"
 EXAMPLE: FTH-5-01-M FOR 1000 PCS PER BAG.
 -C = 100 PCS
 -M = 1000 PCS

K	ADDED FTH-5-DHB, ECN # 1429	DZ	04/05/2017	TITLE: FLAT TIE HOLDER					UNITS: INCH [mm]
J	ADDED NOTE 2. SEE CO 200661 FOR CHANGES	SK	05/12/2011	FILE #: FTH-5	DWN: SK	APP: -	FINAL		
I	SEE CO 200570 FOR CHANGES	SK	08/04/2010	SHEET: 1 OF 1	SHEET SIZE: A	DT: 03/10/2005	CHKD: -	PART #	
H	SEE CO 200248 FOR CHANGES	SK	10/30/2008	RE: -			ESSENTRA	SEE TABLE	
G	SEE ECN #1124 FOR CHANGES	SK	01/24/2006			COMPONENTS		PRINT TYPE	
F	SEE ECN #962 FOR CHANGES	SK	03/10/2005					CA	
-	SEE ENGINEERING FOR REV. A-E	-	----						
REV.	DESCRIPTION	ENGR.	DATE						