



Chipsmall Limited consists of a professional team with an average of over 10 year of expertise in the distribution of electronic components. Based in Hongkong, we have already established firm and mutual-benefit business relationships with customers from,Europe,America and south Asia,supplying obsolete and hard-to-find components to meet their specific needs.

With the principle of “Quality Parts,Customers Priority,Honest Operation,and Considerate Service”,our business mainly focus on the distribution of electronic components. Line cards we deal with include Microchip,ALPS,ROHM,Xilinx,Pulse,ON,Everlight and Freescale. Main products comprise IC,Modules,Potentiometer,IC Socket,Relay,Connector.Our parts cover such applications as commercial,industrial, and automotives areas.

We are looking forward to setting up business relationship with you and hope to provide you with the best service and solution. Let us make a better world for our industry!



## Contact us

Tel: +86-755-8981 8866 Fax: +86-755-8427 6832

Email & Skype: info@chipsmall.com Web: www.chipsmall.com

Address: A1208, Overseas Decoration Building, #122 Zhenhua RD., Futian, Shenzhen, China



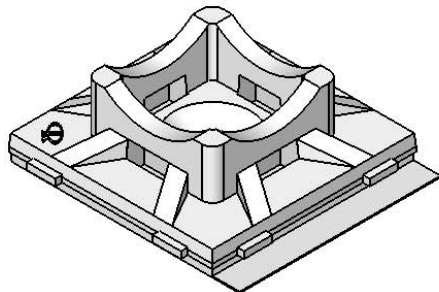

PART NO.	MATERIAL	COLOR	ADHESIVE
FTH-5-01	NYLON 6/6 (RMS-01)	NATURAL	NONE
FTH-5A-RT			ACRYLIC TAPE (RMS-15), WHITE LINER
FTH-5A1-RT			RUBBER TAPE (RMS-102), BLUE LINER
FTH-5-UVB	UVB STABILIZED NYLON (RMS-46)	BLACK	NONE
FTH-5A-RT-UVB			ACRYLIC TAPE (RMS-15), WHITE LINER
*FTH-5A1-RT-UVB			RUBBER TAPE (RMS-102), BLUE LINER

\*AVAILABLE BY SPECIAL ORDER ONLY

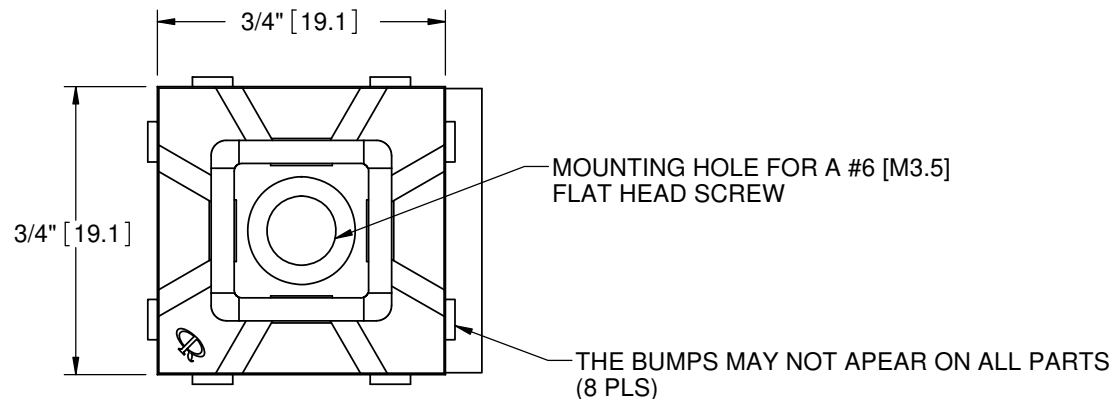

ACCOMODATES WIT-18 TIES

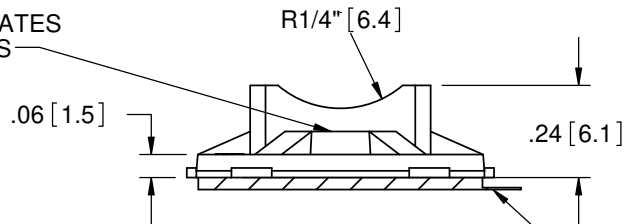

NOTES:

- MATERIAL: FLAME RETARDANT NYLON 6/6 (RMS-19)  
COLOR NATURAL.  
AVAILABLE BY SPECIAL ORDER ONLY.
- PACKAGING QUANTITIES ARE REFLECTED AS THE SUFFIX "-LETTER"  
EXAMPLE: FTH-5-01-M FOR 1000 PCS PER BAG.  
-C = 100 PCS  
-M= 1000 PCS

REV.			TITLE: FLAT TIE HOLDER				DWG IN IN [MM]		PRINT TYPE	
J	ADDED NOTE 2. SEE CO 200661 FOR CHANGES	SK 05.12.11	FILE #: FTH-5		DWN: SK	APP: -	FINAL			
I	SEE CO 200570 FOR CHANGES	SK 08/04/10	SHEET: 1 OF 1		SHEET SIZE: A	DT: 03/10/05	CHKD: -	<b>SEE TABLE</b>		
H	SEE CO 200248 FOR CHANGES	SK 10/30/08	RE: RICHCO, INC.		RICHCO, INC.		<b>CA</b>			
G	SEE ECN #1124 FOR CHANGES	SK 01/24/06	ENG@RICHCO-INC.COM		(773) 539-4060					
F	SEE ECN #962 FOR CHANGES	SK 03/10/05	TOLERANCES UNLESS NOTED							
-	SEE ENGINEERING FOR REV. A-E	-	.XX=±.010							
REV.	DESCRIPTION	ENGR. DATE	.XXX=±.005							
			FRAC.=±1/64							
			ANG.=±1°							