



Chipsmall Limited consists of a professional team with an average of over 10 year of expertise in the distribution of electronic components. Based in Hongkong, we have already established firm and mutual-benefit business relationships with customers from,Europe,America and south Asia,supplying obsolete and hard-to-find components to meet their specific needs.

With the principle of “Quality Parts,Customers Priority,Honest Operation,and Considerate Service”,our business mainly focus on the distribution of electronic components. Line cards we deal with include Microchip,ALPS,ROHM,Xilinx,Pulse,ON,Everlight and Freescale. Main products comprise IC,Modules,Potentiometer,IC Socket,Relay,Connector.Our parts cover such applications as commercial,industrial, and automotives areas.

We are looking forward to setting up business relationship with you and hope to provide you with the best service and solution. Let us make a better world for our industry!



Contact us

Tel: +86-755-8981 8866 Fax: +86-755-8427 6832

Email & Skype: info@chipsmall.com Web: www.chipsmall.com

Address: A1208, Overseas Decoration Building, #122 Zhenhua RD., Futian, Shenzhen, China



Product Specification

Short-Wavelength GBIC Transceiver

FTL-8519-3D

Product Features

- Up to 1.25Gb/s bi-directional data links
- 850nm VCSEL Laser Transmitter
- Optional Digital Diagnostics Functions
- Extended Operating Temperature Range (-10°C to +85°C)
- Compatible with 3.3V & 5V Systems
- Hot-Pluggable (complies with GBIC specification Rev. 5.5)
- Fully metallic enclosure for low EMI
- Low power dissipation
- RoHS compliant and Lead Free



Applications

- 1.0625Gb/s Fibre Channel
- 1.25 Gigabit Ethernet

Finisar's FTL-8519-3D 850nm GBIC transceivers comply with GBIC Specification Revision 5.5¹. They are compatible with the Gigabit Ethernet as specified in IEEE Std 802.3², Fibre Channel FC-PH, PH2, PH3³ and FC-PI-2 Rev. 10.0⁴. They are RoHS compliant and lead-free per Directive 2002/95/EC⁵ and Finisar Application Note AN-2038⁶.

Product Selection

Part Number	Digital Diagnostics?
FTL-8519-3D	No
FTL-8519-3D-DD	Yes

I. Pin Out

Pin Name	Pin #	Sequence
RX_LOS	1	2
GND	2	2
GND	3	2
MOD_DEF(0)	4	2
MOD_DEF(1)	5	2
MOD_DEF(2)	6	2
TX_DISABLE	7	2
GND	8	2
GND	9	2
TX_FAULT (not supported)	10	2
GND	11	1
-RX_DAT	12	1
+RX_DAT	13	1
GND	14	1
V _{CC}	15	2
V _{CC}	16	2
GND	17	1
+TX_DAT	18	1
-TX_DAT	19	1
GND	20	1

Table 1. GBIC to host connector pin assignment

“Sequence” indicates the order in which pins make contact when the device is hot plugged. Also see “Table 3: Signal Definitions” in the GBIC Specification Revision 5.5.¹

II. Electrical Power Interface

Finisar FTL-8519-3D GBICs have an extended power supply voltage range of 3.15 V to 5.5 V as described in Table 2. They are compatible with both 3.3V and 5 V systems.

+5/3.3 Volt Electrical Power Interface						
Parameter	Symbol	Min	Typ	Max	Units	Notes/Conditions
Supply Current	I_s		190	300	mA	
Surge Current	I_{surge}			330	mA	Hot plug
Absolute Supply Voltage	V_{max}	-0.3		6	V	Not to be applied continuously
Operating Supply Voltage	V_{cc}	3.15	3.3, 5.0	5.5	V	

Table 2. Electrical power interface

III. Low Speed Signals

RX_LOS, and TX_DISABLE are TTL signals as described in Table 3. MOD_DEF(1) (SCL) and MOD_DEF(2) (SDA), are open drain CMOS signals (see section VI, “Serial Communication Protocol”). Both MOD_DEF(1) and MOD_DEF(2) must be pulled up to host_Vcc. If host_Vcc is 3.3V, then they must be pulled to 3.3V. If host_Vcc is 5V, do not pull the MOD_DEF pins to 5V.

For more detailed information, see sections 5.3.1 – 5.3.8 in the GBIC Specification Rev. 5.5¹.

Low Speed Signals, Electronic Characteristics						
Parameter	Symbol	Min	Max	Units	Notes/Conditions	
GBIC Output LOW	V_{OL}	0	0.5	V	4.7k to 10k pull-up to host_Vcc, measured at host side of connector	
GBIC Output HIGH	V_{OH}	host_Vcc - 0.5	host_Vcc + 0.3	V	4.7k to 10k pull-up to host_Vcc, measured at host side of connector	
GBIC Input LOW	V_{IL}	0	0.8	V	4.7k to 10k pull-up to Vcc, measured at GBIC side of connector*	
GBIC Input HIGH	V_{IH}	2	Vcc + 0.3	V	4.7k to 10k pull-up to Vcc, measured at GBIC side of connector*	

*Note V_{IH} and V_{IL} are the same for both 5V and 3.3V operation

Table 3. Low speed signals – electronic characteristics

Low Speed Signal Parameters						
Parameter	Symbol	Min	Typ	Max	Units	Notes/Conditions
RX_LOS Assert Level	--	-30			dBm	
RX_LOS Deassert Level	--			-19	dBm	
RX_LOS Hysteresis	--	0.5			dB	
RX_LOS Assert Delay	t_loss_on		44	100	μsec	From detection of loss of signal to assertion of RX_LOS
RX_LOS Negate Delay	t_loss_off		44	100	μsec	From detection of presence of signal to negation of RX_LOS
TX_DISABLE Assert Time	t_off			10	μsec	Rising edge of TX_DISABLE to fall of output signal below 10% of nominal
TX_DISABLE Negate Time	t_on			1000	μsec	Falling edge of TX_DISABLE to rise of output signal above 90% of nominal
TX_DISABLE Reset Time	t_reset	10			μsec	TX_DISABLE HIGH before TX_DISABLE set LOW

Table 4. Low speed signal parameters

IV. High Speed Electrical Interface

All high-speed PECL signals are AC-coupled internally.

High Speed Electrical Interface						
Parameter	Symbol	Min	Typ	Max	Units	Notes/Conditions
Data Input Voltage	V _{in}	650		2000	mV	PECL differential peak - peak
Data Output Voltage	V _{out}	370		2000	mV	PECL differential peak - peak
PECL rise/fall	t _r ,t _f			260	psec	20%-80% differential
Bit Error Rate	BER			10 ⁻¹²		PRBS 2 ⁷ - 1 test data pattern
Tx Input Impedance	Z _{in}		75		ohm	
Rx Output Impedance	Z _{out}		75		ohm	

Table 5. High-speed electrical interface

V. Optical Parameters

Optical Parameters						
Parameter	Symbol	Min	Typ	Max	Units	Notes/Conditions
Transmitter Center Wavelength	λ_c	820	850	860	nm	
Transmitter Spectral Width (RMS)	$\Delta\lambda$		0.5	0.85	nm	RMS
Transmitter Optical Output Power	P_{out}	-9.5		-3.5	dBm	Average Power
Transmitter Extinction Ratio	OMI	9			dB	
Relative Intensity Noise	RIN			-117	dB/Hz	
Transmitter Eye Opening	--	60			%	Conforms to IEEE 802.3 and Fibre Channel Eye Masks
Total Transmitter Jitter	TJ_{TX}			180	ps	Peak to peak, filtered
Transmitter Rise/Fall Time	Tr/Tf			210	ps	Unfiltered 20%-80%
Optical Input Wavelength	λ_{in}	770		860	nm	
Optical Receiver Sensitivity	R_{XSENS}			-19	dBm	BER < 10^{-12} w/ PRBS $2^7 - 1$ test data pattern @ 1.25Gb/s
Average Received Power	R_{XMAX}			0	dBm	
Max Reflectivity				-14	dB	
Total Receiver Jitter	TJ_{RX}			180	ps	Peak to peak, filtered in loopback

Table 6. Optical parameters**VI. General Specifications**

General						
Parameter	Symbol	Min	Typ	Max	Units	Notes/Conditions
Data Rate	BR		1.25, 1.0625		Gb/sec	Fibre Channel, IEEE 802.3 Compatible. Rate tolerance = ± 100 ppm
Fiber Length	L			550	m	50 μ m 500MHz-km Fiber
Fiber Length	L			275	m	62.5 μ m 200MHz-km Fiber

Table 7. General specifications

VII. Environmental Specifications

Note that the GBIC Specification requires an ambient temperature range of 0 to 50°C. Finisar GBICs have an extended range from –10°C to +85°C case temperature as specified in Table 8.

Environment						
Parameter	Symbol	Min	Typ	Max	Units	Notes/Conditions
Operating Temp	T _{op}	-10		85	°C	Case Temperature
Relative Humidity	RH	0		85	%	Non Condensing
Storage Temp	T _{sto}	-40		85	°C	
Eye Safety	--					CDRH and IEC-825 Class 1 Laser Product

Table 8. Environmental Specifications

VIII. Serial Communication Protocol

All Finisar optical GBICs implement serial identification features described for ‘Module Definition “4”’ as outlined in Annex D of the GBIC Specification¹. These GBICs use an Atmel AT24C01A 128 byte E²PROM at address A0H. For details on interfacing with the E²PROM, see the Atmel data sheet titled “AT24C01A/02/04/08/16 2-Wire Serial CMOS E²PROM.”⁷

The FTL-8519-3D also supports extended diagnostic features as described in Finisar Applications Note AN-2030, “Digital Diagnostic Monitoring Interface for Optical Transceivers”⁸, and additional information is available in SFF standard titled: “Digital Diagnostic Monitoring Interface for Optical Transceivers”⁹ (SFF-8472 Rev. 9.3). A controller IC that monitors system parameters such as laser current, module temperature, transmitter power, and received power is accessible at address A2H.

I2C clock speed, digital diagnostic accuracy and digital diagnostic range can be found in the table below. Values in the table represent the worst-case values over temperature, voltage, and life.

Parameter	Symbol	Min	Typ	Max	Units	Notes/Conditions
I ² C Clock Speed		0		100,000	Hz	Bus can be driven blind
Accuracy						
Internal Transceiver Temperature	DD _{Temperature}	-3		+3	°C	Measured at controller IC
Internal Transceiver Supply Voltage	DD _{Voltage}	-3		+3	%	Measured at controller IC
Tx Bias Current	DD _{Bias}	-10		+10	%	
Tx Output Power	DD _{TxPower}	-3		+3	dB	100% tested in production tested at room temp to ±2 dB
Received Average Power	DD _{RxPower}	-3		+3	dB	100% tested in production tested at room temp to ±2 dB
Range						
Internal Transceiver Temperature	DD _{Temperature}	-40		100	°C	
Internal Transceiver Supply Voltage	DD _{Voltage}	3.0		6.0	V	
Tx Bias Current	DD _{Bias}	0		15	mA	
Tx Output Power	DD _{TxPower}	-12		-2	dBm	
Received Average Power	DD _{RxPower}	-20		1	dBm	

Table 9. Digital Diagnostic Accuracy and Range Limits**X. Mechanical Specifications**

Finisar GBICs are compatible with the mechanical specifications outlined in the GBIC Specification Revision 5.5, Section 6¹.

Insertion, Extraction, and Retention Forces						
Parameter	Symbol	Min	Typ	Max	Units	Notes/Conditions
GBIC insertion	F _I	0		20	Newtons	~4.5 lbs
GBIC extraction	F _E	0		15	Newtons	~3.3 lbs
GBIC retention	F _R	130		N/A	Newtons	Straight out ~29.3 lbs

Table 10. Insertion, extraction, and retention forces

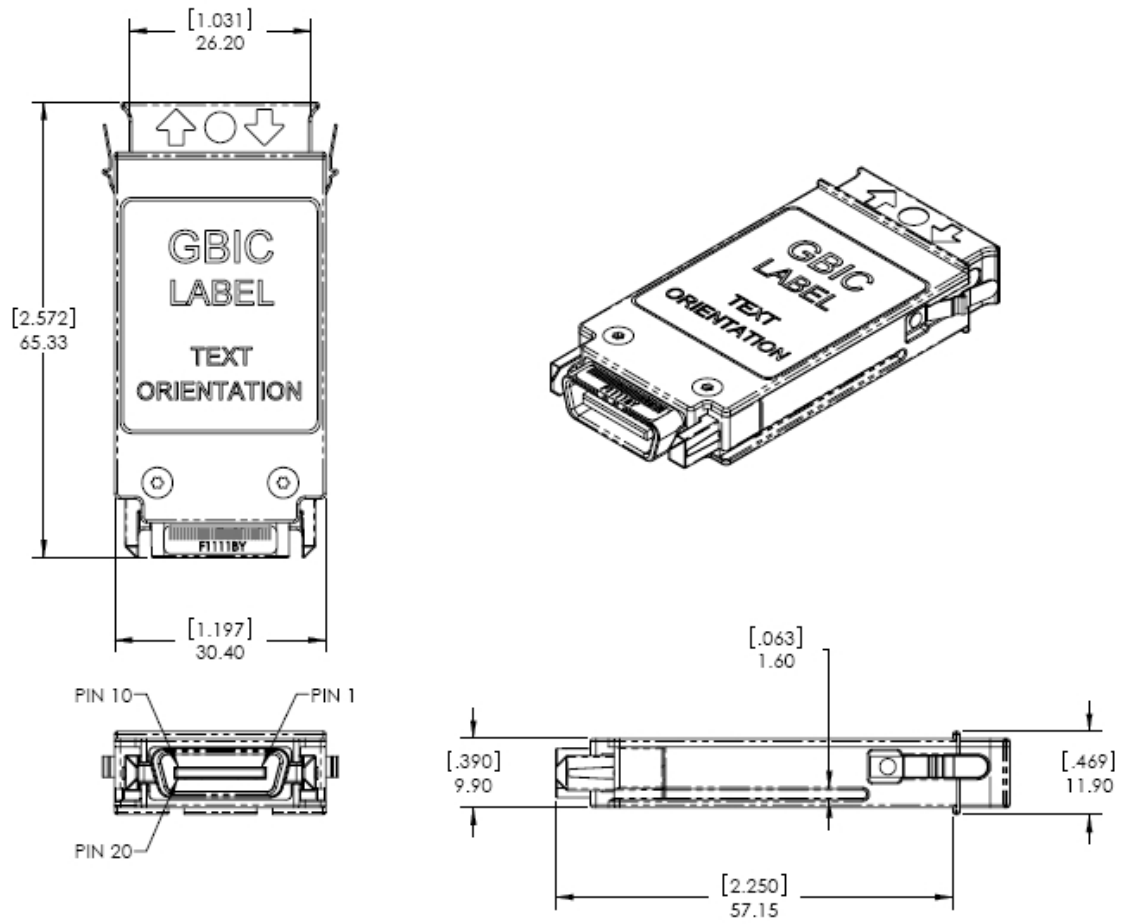

Figure 1. GBIC Outline Drawing

XI. References

1. “Gigabit Interface Converter (GBIC) Revision 5.5”. Sun Microsystems Computer Company et. al., September 27, 2000. <http://playground.sun.com/pub/OEmod/>
2. IEEE Std 802.3. IEEE Standards Department, 2002.
3. “Fibre Channel Physical and Signaling Interface (FC-PH, FC-PH2, FC-PH3)”. American National Standard for Information Systems.
4. Fibre Channel Draft Physical Interface Specification (FC-PI-2 Rev. 10.0). American National Standard for Information Systems.
5. Directive 2002/95/EC of the European Council Parliament and of the Council, “on the restriction of the use of certain hazardous substances in electrical and electronic equipment.” January 27, 2003.
6. “Application Note AN-2038: Finisar Implementation of RoHS Compliant Transceivers”, Finisar Corporation, March 2005.
7. “AT24C01A/02/04/08/16 2-Wire Serial CMOS E²PROM”. Atmel Corporation. www.Atmel.com
8. “Application Note AN-2030: Digital Diagnostic Monitoring Interface for Optical Transceivers”, Finisar Corporation, April 2002.
9. “Digital Diagnostics Monitoring Interface for Optical Transceivers”. SFF Document Number SFF-8472, Revision 9.3.

XI. For More Information

Finisar Corporation
1389 Moffett Park Drive
Sunnyvale, CA 94089-1134
Tel. 1-408-548-1000
Fax 1-408-541-6138
sales@finisar.com
www.finisar.com