



Chipsmall Limited consists of a professional team with an average of over 10 year of expertise in the distribution of electronic components. Based in Hongkong, we have already established firm and mutual-benefit business relationships with customers from,Europe,America and south Asia,supplying obsolete and hard-to-find components to meet their specific needs.

With the principle of “Quality Parts,Customers Priority,Honest Operation,and Considerate Service”,our business mainly focus on the distribution of electronic components. Line cards we deal with include Microchip,ALPS,ROHM,Xilinx,Pulse,ON,Everlight and Freescale. Main products comprise IC,Modules,Potentiometer,IC Socket,Relay,Connector.Our parts cover such applications as commercial,industrial, and automotives areas.

We are looking forward to setting up business relationship with you and hope to provide you with the best service and solution. Let us make a better world for our industry!



Contact us

Tel: +86-755-8981 8866 Fax: +86-755-8427 6832

Email & Skype: info@chipsmall.com Web: www.chipsmall.com

Address: A1208, Overseas Decoration Building, #122 Zhenhua RD., Futian, Shenzhen, China



Preliminary Product Specification

4x10GBASE-LR QSFP+ Optical Transceiver Module

FTL4P1QE1C

PRODUCT FEATURES

- Hot-pluggable QSFP+ form factor
- Supports 4 independent streams of 10GBASE-LR
- Power dissipation < 2.5W
- RoHS-6 compliant
- Commercial case temperature range 0°C to 70°C
- Single 3.3V power supply
- Maximum link length of 10km on Single Mode Fiber (SMF)
- XLPP electrical interface
- MPO12 receptacle
- Built-in digital diagnostic functions, including Tx/Rx power monitoring

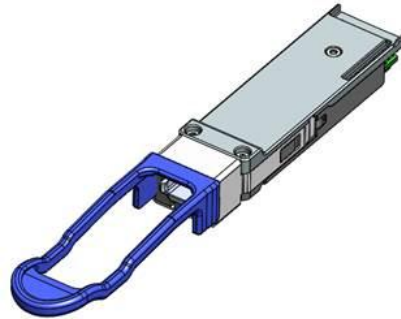

APPLICATIONS

- 10GBASE-LR/LW 10G Ethernet

Finisar's FTL4P1QE1C QSFP+ transceiver modules are designed for use in high density 10 Gigabit Ethernet links over single mode fiber. They are compliant with the QSFP+ MSA^{1,2} and IEEE 802.3ae 10GBASE-LR/LW³. Digital diagnostics functions are available via an I2C interface, as specified by the QSFP+ MSA. The transceiver is RoHS compliant per Directive 2011/65/EU⁴ and Finisar Application Note AN-2038⁵.

PRODUCT SELECTION

FTL4P1QE1C

- 4: 4 channel module
- P1: Parallel single mode
- Q: QSFP+ form factor
- E: 10GBASE-LR/LW compliant optical interface
- 1: First generation product
- C: Commercial temperature rate

I. Pin Descriptions

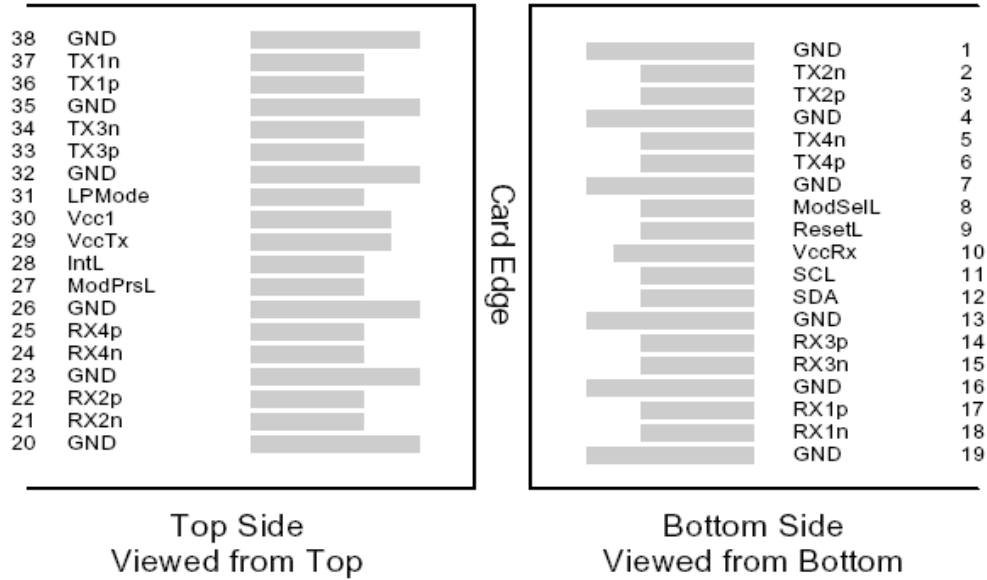

Figure 1 – QSFP+ MSA-compliant 38-pin connector

Pin	Symbol	Name/Description	Notes
1	GND	Ground	1
2	Tx2n	Transmitter Inverted Data Input	
3	Tx2p	Transmitter Non-Inverted Data Input	
4	GND	Ground	1
5	Tx4n	Transmitter Inverted Data Input	
6	Tx4p	Transmitter Non-Inverted Data Input	
7	GND	Ground	1
8	ModSelL	Module Select	
9	ResetL	Module Reset	
10	Vcc Rx	+3.3 V Power supply receiver	
11	SCL	2-wire serial interface clock	
12	SDA	2-wire serial interface data	
13	GND	Ground	1
14	Rx3p	Receiver Non-Inverted Data Output	
15	Rx3n	Receiver Inverted Data Output	
16	GND	Ground	1
17	Rx1p	Receiver Non-Inverted Data Output	
18	Rx1n	Receiver Inverted Data Output	
19	GND	Ground	1
20	GND	Ground	1
21	Rx2n	Receiver Inverted Data Output	
22	Rx2p	Receiver Non-Inverted Data Output	
23	GND	Ground	1
24	Rx4n	Receiver Inverted Data Output	
25	Rx4p	Receiver Non-Inverted Data Output	

26	GND	Ground	1
27	ModPrsL	Module Present	
28	IntL	Interrupt	
29	Vcc Tx	+3.3 V Power supply transmitter	
30	Vcc1	+3.3 V Power Supply	
31	LPMode	Low Power Mode	
32	GND	Ground	1
33	Tx3p	Transmitter Non-Inverted Data Input	
34	Tx3n	Transmitter Inverted Data Input	
35	GND	Ground	1
36	Tx1p	Transmitter Non-Inverted Data Input	
37	Tx1n	Transmitter Inverted Data Input	
38	GND	Ground	1

Notes

1. Circuit ground is internally isolated from chassis ground.

II. General Product Characteristics

Parameter	Value	Unit	Notes
Module Form Factor	QSFP+		
Maximum Aggregate Data Rate	41.2	Gb/s	
Maximum Data Rate per Lane	10.3125	Gb/s	
Protocols Supported	10G Ethernet		
Electrical Interface and Pin-out	38-pin edge connector		Pin-out as defined by the QSFP+ MSA
Maximum Power Consumption	2.5	Watts	
Management Interface	Serial, I2C-based, 400 kHz maximum frequency		As defined by the QSFP+ MSA

Data Rate Specifications	Symbol	Min	Typ	Max	Units	Ref.
Bit Rate per Lane	BR	9.95		10.313	Gb/sec	1
Bit Error Ratio	BER			10^{-12}		2
Link distance on SMF-28	d			10	kilometers	3

Notes:

1. Compliant with 10GBASE-LR/LW and XLPP1 per IEEE 802.3ae.
2. Tested with a PRBS $2^{31}-1$ test pattern.
3. Per 10GBASE-LR, IEEE 802.3ae.

III. Absolute Maximum Ratings

Parameter	Symbol	Min	Typ	Max	Unit	Ref.
Maximum Supply Voltage	V _{cc1} , V _{ccTx} , V _{ccRx}	-0.5		3.6	V	
Storage Temperature	T _S	-40		85	°C	
Case Operating Temperature	T _{OP}	0		70	°C	
Relative Humidity	RH	0		85	%	1
Damage Threshold, per Lane	DT	3.4			dBm	

Notes:

1. Non-condensing.

IV. Electrical Characteristics (T_{OP} = 0 to 70°C, V_{CC} = 3.1 to 3.47 Volts)

Parameter	Symbol	Min	Typ	Max	Unit	Ref.
Supply Voltage	V _{cc1} , V _{ccTx} , V _{ccRx}	3.1		3.47	V	
Supply Current	I _{cc}			????	A	
Link turn-on time						
Transmit turn-on time				2000	ms	2
Transmitter (per Lane)						
Single ended input voltage tolerance	V _{inT}	-0.3		4.0	V	
Differential data input swing	V _{in,pp}	120		1200	mV _{pp}	3
Differential input threshold			50		mV	
AC common mode input voltage tolerance (RMS)		15			mV	
Differential input return loss		Per IEEE P802.3ba, Section 86A.4.1.1			dB	4
J2 Jitter Tolerance	J _{t2}	0.17			UI	
J9 Jitter Tolerance	J _{t9}	0.29			UI	
Data Dependent Pulse Width Shrinkage	DDPWS	0.07			UI	
Eye mask coordinates {X1, X2 Y1, Y2}			0.11, 0.31 95, 350		UI mV	5
Receiver (per Lane)						
Single-ended output voltage		-0.3		4.0	V	
Differential data output swing	V _{out,pp}	200		400	mV _{pp}	6,7
		300		600		
		400		800		
		600		1200		
AC common mode output voltage (RMS)				7.5	mV	
Termination mismatch at 1 MHz				5	%	
Differential output return loss		Per IEEE P802.3ba, Section 86A.4.2.1			dB	4
Common mode output return loss		Per IEEE P802.3ba, Section 86A.4.2.2			dB	4
Output transition time, 20% to 80%		28			ps	
J2 Jitter output	J _{o2}			0.42	UI	
J9 Jitter output	J _{o9}			0.65	UI	

Eye mask coordinates #1 {X1, X2 Y1, Y2}		0.29, 0.5 150, 425	UI mV	5
Power Supply Ripple Tolerance	PSR	50	mVpp	

Notes:

1. Maximum total power value is specified across the full temperature and voltage range.
2. From power-on and end of any fault conditions.
3. After internal AC coupling. Self-biasing 100Ω differential input.
4. 10 MHz to 11.1 GHz range.
5. Hit ratio = 5 x 10E-5.
6. AC coupled with 100Ω differential output impedance.
7. Output voltage settable in four discrete ranges via I2C command.

V. Optical Characteristics (T_{OP} = 0 to 70°C, V_{CC} = 3.1 to 3.47 Volts)

Parameter	Symbol	Min	Typ	Max	Unit	Ref.
Transmitter						
Signaling Speed per Lane		9.95		10.3125	GBd	1
Lane center wavelength	λ	1260		1355		
Total Average Launch Power	P _{OUT}			8.3	dBm	
Transmit OMA per Lane	T _x OMA	-5.2		3.0	dBm	
Transmitter and Dispersion Penalty	TDP			3.2	dB	
Average Launch Power per Lane	T _x P _x	-8.2		0.5	dBm	2
Optical Extinction Ratio	ER	3.5			dB	
Sidemode Suppression ratio	SSR _{min}	30			dB	
Average launch power of OFF transmitter, per lane				-30	dBm	
Relative Intensity Noise	RIN			-128	dB/Hz	3
Tx Jitter	T _{xj}			20	dB	
Transmitter Reflectance		Per 802.3ae requirements				
Transmitter eye mask definition		Per 802.3ae requirements				
Receiver						
Signaling Speed per Lane		9.95		10.3125	GBd	4
Lane center wavelength	λ	1260		1355		
Average Receive Power per Lane	R _x P _x	-14.2		0.5	dBm	5
Receiver Sensitivity (OMA) per Lane	R _x sens			-12.6	dBm	
Stressed Receiver Sensitivity (OMA) per Lane	SRS			-10.3	dBm	
Damage Threshold per Lane	P _{MAX}			3.5	dBm	
Return Loss	R _L			-12	dB	
Receive electrical 3 dB upper cutoff frequency, per lane				12.3	GHz	
LOS De-Assert	LOS _D			-17	dBm	
LOS Assert	LOS _A	-30			dBm	
LOS Hysteresis			0.5		dB	

Notes:

1. Transmitter consists of 4 lasers operating at 9.95 or 10.3Gb/s each.
2. Minimum value is informative.
3. RIN is scaled by $10 \cdot \log(10/4)$ to maintain SNR outside of transmitter.
4. Receiver consists of 4 photodetectors operating at 9.95 or 10.3Gb/s each.
5. Minimum value is informative, equals min TxOMA with infinite ER and max channel insertion loss.

VI. Digital Diagnostic Specifications

FTL4P1QE1C transceivers can be used in host systems that require either internally or externally calibrated digital diagnostics.

Parameter	Symbol	Min	Typ	Max	Units	Ref.
Accuracy						
Internally measured transceiver temperature	$\Delta DD_{Temperature}$			3	°C	
Internally measured transceiver supply voltage	$\Delta DD_{Voltage}$			3	%	
Measured TX bias current	ΔDD_{Bias}			10	%	1
Measured TX output power	$\Delta DD_{Tx-Power}$			2	dB	
Measured RX received average optical power	$\Delta DD_{Rx-Power}$			2	dB	
Dynamic Range for Rated Accuracy						
Internally measured transceiver temperature	$DD_{Temperature}$	-5		70	°C	
Internally measured transceiver supply voltage	$DD_{Voltage}$	3.1		3.5	V	
Measured TX bias current	DD_{Bias}	10		90	mA	
Measured TX output power	$DD_{Tx-Power}$	-8.2		+0.5	dBm	
Measured RX received average optical power	$DD_{Rx-Power}$	-14.2		+0.5	dBm	
Max Reporting Range						
Internally measured transceiver temperature	$DD_{Temperature}$	-40		125	°C	
Internally measured transceiver supply voltage	$DD_{Voltage}$	2.8		4.0	V	
Measured TX bias current	DD_{Bias}	0		20	mA	
Measured TX output power	$DD_{Tx-Power}$	-10		+2	dBm	
Measured RX received average optical power	$DD_{Rx-Power}$	-22		+2	dBm	

Notes:

1. Accuracy of measured Tx bias current is 10% of the actual bias current from the laser driver to the laser.

VII. Memory Map and Control Registers

Compatible with SFF-8436 (QSFP+). Please see Finisar Application Note AN-2104⁶.

VIII. Environmental Specifications

Finisar FTL4P1QE1C transceivers have an operating temperature range from 0°C to +70°C case temperature.

Environmental Specifications	Symbol	Min	Typ	Max	Units	Ref.
Case Operating Temperature	T _{op}	0		70	°C	
Storage Temperature	T _{sto}	-40		85	°C	

IX. Regulatory Compliance

Finisar FTL4P1QE1C transceivers are RoHS-6 Compliant. Copies of certificates are available at Finisar Corporation upon request.

FTL4P1QE1C transceiver modules are Class 1 laser eye safety compliant per IEC 60825-1.

X. Mechanical Specifications

The FTL4P1Q mechanical specifications are compliant to the QSFP+ MSA transceiver module specifications.

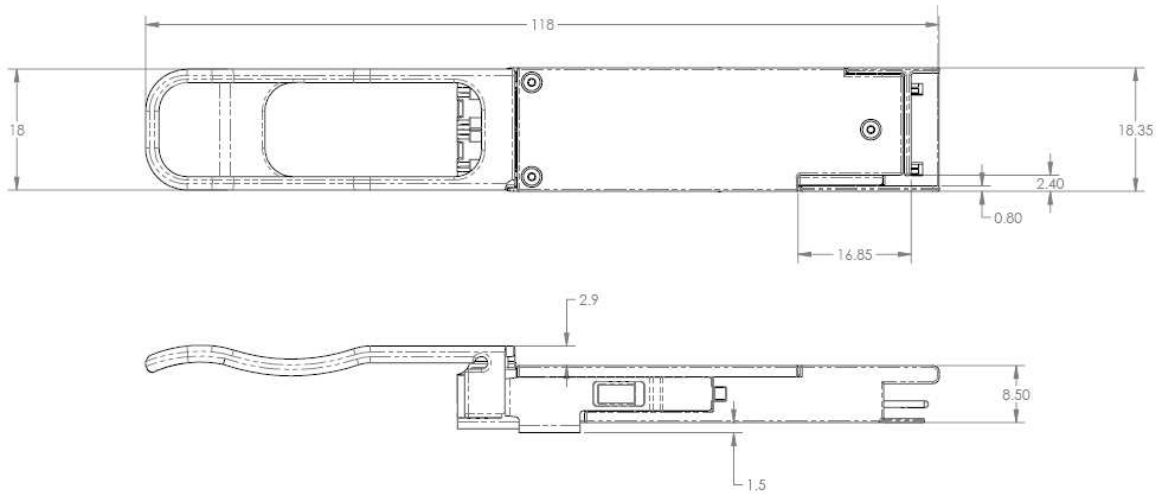

Figure 2 – FTL4P1QE1C mechanical drawing

The FTL4P1QM1C pull tab color is dark blue Pantone 2748.



Figure 3 – FTL4P1QE1C label (not to scale)

The FTL4P1QE1C optical interface accepts an 8° angled MPO connector, with lane assignments as shown in Figure 4.

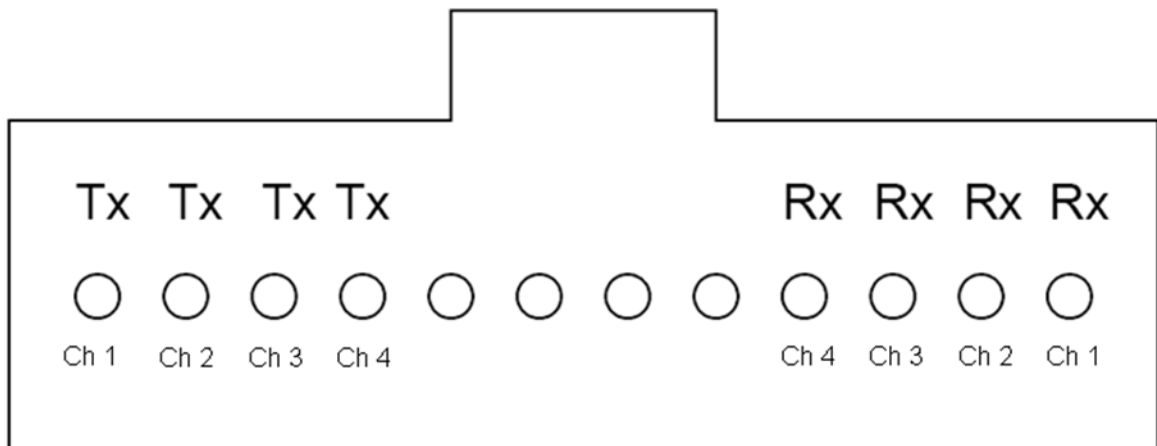

Figure 4 – FTL4P1QE1C optical lane assignment (front view of MPO receptacle)

XI. References

1. SFF-8436 – Specification for QSFP+ 10 Gbs 4x Pluggable Transceiver, Rev 4.8, October 2013.
2. SFF-8636 – Specification for Common Management Interface, Rev 1.7, January 2014.
3. 802.3-2012, IEEE Standard for Ethernet, Section 4, Clause 52, PMD Types 10GBASE-LR/LW.
4. Directive 2011/65/EU of the European Council Parliament and of the Council, “on the restriction of the use of certain hazardous substances in electrical and electronic equipment,” June 8, 2011, which supercedes the previous RoHS Directive 2002/95/EC.
5. “Application Note AN-2038: Finisar Implementation of RoHS Compliant Transceivers”, Finisar Corporation, January 21, 2005.
6. “Application Note AN-2104: QSFP+ 40G LR4 Transceiver EEPROM Mapping,” Rev. A, Finisar Corporation, June, 2013.

XII. For More Information

Finisar Corporation
1389 Moffett Park Drive
Sunnyvale, CA 94089-1133
Tel. 1-408-548-1000
Fax 1-408-541-6138
sales@finisar.com
www.finisar.com