



Chipsmall Limited consists of a professional team with an average of over 10 year of expertise in the distribution of electronic components. Based in Hongkong, we have already established firm and mutual-benefit business relationships with customers from,Europe,America and south Asia,supplying obsolete and hard-to-find components to meet their specific needs.

With the principle of “Quality Parts,Customers Priority,Honest Operation,and Considerate Service”,our business mainly focus on the distribution of electronic components. Line cards we deal with include Microchip,ALPS,ROHM,Xilinx,Pulse,ON,Everlight and Freescale. Main products comprise IC,Modules,Potentiometer,IC Socket,Relay,Connector.Our parts cover such applications as commercial,industrial, and automotives areas.

We are looking forward to setting up business relationship with you and hope to provide you with the best service and solution. Let us make a better world for our industry!



Contact us

Tel: +86-755-8981 8866 Fax: +86-755-8427 6832

Email & Skype: info@chipsmall.com Web: www.chipsmall.com

Address: A1208, Overseas Decoration Building, #122 Zhenhua RD., Futian, Shenzhen, China



I. Pin Descriptions

Pin	Symbol	Name/Description	Ref.
1	V _{EET}	Transmitter Ground (Common with Receiver Ground)	1
2	T _{FAULT}	Transmitter Fault.	2
3	T _{DIS}	Transmitter Disable. Laser output disabled on high or open.	3
4	MOD_DEF(2)	Module Definition 2. Data line for Serial ID.	4
5	MOD_DEF(1)	Module Definition 1. Clock line for Serial ID.	4
6	MOD_DEF(0)	Module Definition 0. Grounded within the module.	4
7	Rate Select	No connection required	5
8	LOS	Loss of Signal indication. Logic 0 indicates normal operation.	6
9	V _{EER}	Receiver Ground (Common with Transmitter Ground)	1
10	V _{EER}	Receiver Ground (Common with Transmitter Ground)	1
11	V _{EER}	Receiver Ground (Common with Transmitter Ground)	1
12	RD-	Receiver Inverted DATA out. AC Coupled	
13	RD+	Receiver Non-inverted DATA out. AC Coupled	
14	V _{EER}	Receiver Ground (Common with Transmitter Ground)	1
15	V _{CCR}	Receiver Power Supply	
16	V _{CCT}	Transmitter Power Supply	
17	V _{EET}	Transmitter Ground (Common with Receiver Ground)	1
18	TD+	Transmitter Non-Inverted DATA in. AC Coupled.	
19	TD-	Transmitter Inverted DATA in. AC Coupled.	
20	V _{EET}	Transmitter Ground (Common with Receiver Ground)	1

Notes:

1. Circuit ground is internally isolated from chassis ground.
2. T_{FAULT} is an open collector/drain output, which should be pulled up with a 4.7k – 10k Ohms resistor on the host board if intended for use. Pull up voltage should be between 2.0V to V_{cc} + 0.3V. A high output indicates a transmitter fault caused by either the TX bias current or the TX output power exceeding the preset alarm thresholds. A low output indicates normal operation. In the low state, the output is pulled to <0.8V.
3. Laser output disabled on T_{DIS} >2.0V or open, enabled on T_{DIS} <0.8V.
4. Should be pulled up with 4.7k - 10 kohms on host board to a voltage between 2.0V and 3.6V. MOD_DEF(0) pulls line low to indicate module is plugged in.
5. Finisar FTLF1318xxxx transceivers operate at 1x Fibre Channel and Gigabit Ethernet data rates and respective protocols without active control.
6. LOS is open collector output. Should be pulled up with 4.7k – 10 kohms on host board to a voltage between 2.0V and 3.6V. Logic 0 indicates normal operation; logic 1 indicates loss of signal.

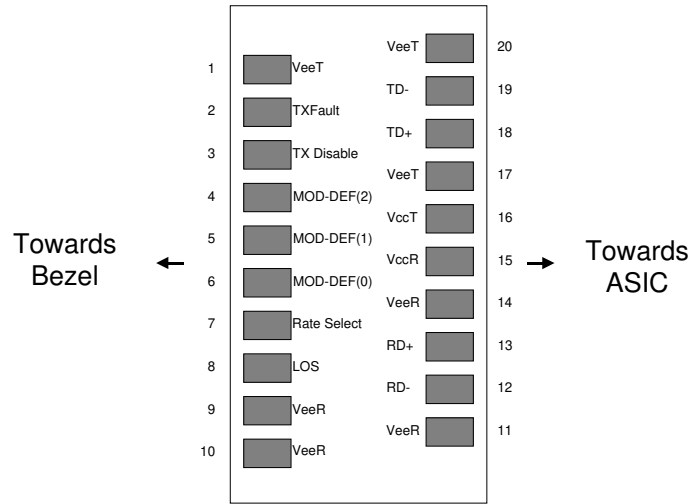

Pinout of Connector Block on Host Board

II. Absolute Maximum Ratings

Parameter	Symbol	Min	Typ	Max	Unit	Ref.
Maximum Supply Voltage	V _{CC}	-0.5		4.0	V	
Storage Temperature	T _S	-40		100	°C	
Case Operating Temperature	T _{OP}	-40		85	°C	
Relative Humidity	RH	0		85	%	1

III. Electrical Characteristics (T_{OP} = -40 to 85 °C, V_{CC} = 3.00 to 3.60 Volts)

Parameter	Symbol	Min	Typ	Max	Unit	Ref.
Supply Voltage	V _{CC}	3.00		3.60	V	
Supply Current	I _{CC}			300	mA	
Transmitter						
Input differential impedance	R _{in}		100		Ω	2
Single ended data input swing	V _{in,pp}	250		1200	mV	
Transmit Disable Voltage	V _D	V _{CC} - 1.3		V _{CC}	V	
Transmit Enable Voltage	V _{EN}	V _{EE}		V _{EE} + 0.8	V	3
Transmit Disable Assert Time				10	us	
Receiver						
Single ended data output swing	V _{out,pp}	300	400	800	mV	4
Data output rise time	t _r			300	ps	5
Data output fall time	t _f			300	ps	5
LOS Fault	V _{LOS fault}	V _{CC} - 0.5		V _{CC HOST}	V	6
LOS Normal	V _{LOS norm}	V _{EE}		V _{EE} + 0.5	V	6
Power Supply Rejection	PSR	100			mVpp	7
Deterministic Jitter Contribution	RX Δ DJ			80	ps	8
Total Jitter Contribution	RX Δ TJ			122.4	ps	

Notes:

1. Non-condensing.
2. AC coupled.
3. Or open circuit.
4. Into 100 ohm differential termination.
5. 20 – 80 %
6. LOS is LVTTTL. Logic 0 indicates normal operation; logic 1 indicates no signal detected.
7. All transceiver specifications are compliant with a power supply sinusoidal modulation of 20 Hz to 1.5 MHz up to specified value applied through the power supply filtering network shown on page 23 of the Small Form-factor Pluggable (SFP) Transceiver MultiSource Agreement (MSA), September 14, 2000.
8. Measured with DJ-free data input signal. In actual application, output DJ will be the sum of input DJ and Δ DJ.

IV. Optical Characteristics (T_{OP} = -40 to 85 °C, V_{CC} = 3.00 to 3.60 Volts)

Parameter	Symbol	Min	Typ	Max	Unit	Ref.
Transmitter						
Output Opt. Power	P _{OUT}	-9.5		-3	dBm	1
Optical Wavelength	λ	1270		1360	nm	2
Spectral Width	σ			3	nm	2
Optical Modulation Amplitude	OMA	174			μ W	2,3
Optical Rise/Fall Time	t _r / t _f		150	260	ps	4
RIN				-120	dB/Hz	
Deterministic Jitter Contribution	TX Δ DJ		20	56.5	ps	5
Total Jitter Contribution	TX Δ TJ		50	119	ps	
Optical Extinction Ratio	ER	9			dB	
Receiver						
Average Rx Sensitivity @ 1.25 Gb/s (Gigabit Ethernet)	R _{SENS2}			-19	dBm	6, 7
Average Rx Sensitivity @ 1.06 Gb/s (1X Fibre Channel)	R _{SENS1}			-21	dBm	6, 7
Stressed RX sens. = 1.25 Gb/s				-14.5	dBm	
Average Received Power	R _{XMAX}			0	dBm	
Receiver Elec. 3 dB cutoff freq.				1500	MHz	
Optical Center Wavelength	λ_C	1265		1600	nm	
Return Loss		12			dB	
LOS De-Assert	LOS _D			-19	dBm	
LOS Assert	LOS _A	-30			dBm	
LOS Hysteresis		0.5			dB	

Notes:

1. Class 1 Laser Safety per FDA/CDRH and EN (IEC) 60825 regulations.
2. Also specified to meet curves in FC-PI-4 Rev. 8.00 Figure 21, which allow trade-off between wavelength, spectral width and OMA.
3. Equivalent extinction ratio specification for Fibre Channel. Allows smaller ER at higher average power.
4. Unfiltered, 20-80%. Complies with IEEE 802.3 (Gig. E) and FC 1x eye masks when filtered.
5. Measured with DJ-free data input signal. In actual application, output DJ will be the sum of input DJ and Δ DJ.
6. Measured with conformance signals defined in FC-PI-4 Rev. 8.00 specifications.
7. Measured with PRBS 2⁷-1 at 10⁻¹² BER

V. General Specifications

Parameter	Symbol	Min	Typ	Max	Units	Ref.
Data Rate	BR	1062		1250	Mb/sec	1
Bit Error Rate	BER			10^{-12}		2
Max. Supported Link Length on 9/125 μ m SMF @ 1X Fibre Channel	L _{MAX1}		10		km	3, 4
Max. Supported Link Length on 9/125 μ m SMF @ Gigabit Ethernet	L _{MAX2}		10		km	3, 4

Notes:

1. Gigabit Ethernet and 1x Fibre Channel compliant.
2. Tested with a PRBS 2^7-1 test pattern.
3. Dispersion limited per FC-PI-4 Rev. 8.00
4. Attenuation of 0.55 dB/km is used for the link length calculations. Distances are indicative only.
Please refer to the Optical Specifications in Table IV to calculate a more accurate link budget based on specific conditions in your application.

VI. Environmental Specifications

Finisar 1310nm Industrial Temperature SFP transceivers have an operating temperature range from -40°C to +85°C case temperature.

Parameter	Symbol	Min	Typ	Max	Units	Ref.
Case Operating Temperature	T _{op}	-40		85	°C	
Storage Temperature	T _{sto}	-40		100	°C	

VII. Regulatory Compliance

Finisar transceivers are Class 1 Laser Products and comply with US FDA regulations. These products are certified by TÜV and CSA to meet the Class 1 eye safety requirements of EN (IEC) 60825 and the electrical safety requirements of EN (IEC) 60950. Copies of certificates are available at Finisar Corporation upon request.

VIII. Digital Diagnostic Functions

Finisar FTLF1318P3BTL SFP transceivers support the 2-wire serial communication protocol as defined in the SFP MSA¹. It is very closely related to the E²PROM defined in the GBIC standard, with the same electrical specifications.

The standard SFP serial ID provides access to identification information that describes the transceiver's capabilities, standard interfaces, manufacturer, and other information.

Additionally, Finisar SFP transceivers provide a unique enhanced digital diagnostic monitoring interface, which allows real-time access to device operating parameters such as transceiver temperature, laser bias current, transmitted optical power, received optical power and transceiver supply voltage. It also defines a sophisticated system of alarm and warning flags, which alerts end-users when particular operating parameters are outside of a factory set normal range.

The SFP MSA defines a 256-byte memory map in E²PROM that is accessible over a 2-wire serial interface at the 8 bit address 1010000X (A0h). The digital diagnostic monitoring interface makes use of the 8 bit address 1010001X (A2h), so the originally defined serial ID memory map remains unchanged. The interface is identical to, and is thus fully backward compatible with both the GBIC Specification and the SFP Multi Source Agreement. The complete interface is described in Finisar Application Note AN-2030: "Digital Diagnostics Monitoring Interface for SFP Optical Transceivers".

The operating and diagnostics information is monitored and reported by a Digital Diagnostics Transceiver Controller (DDTC) inside the transceiver, which is accessed through a 2-wire serial interface. When the serial protocol is activated, the serial clock signal (SCL, Mod Def 1) is generated by the host. The positive edge clocks data into the SFP transceiver into those segments of the E²PROM that are not write-protected. The negative edge clocks data from the SFP transceiver. The serial data signal (SDA, Mod Def 2) is bi-directional for serial data transfer. The host uses SDA in conjunction with SCL to mark the start and end of serial protocol activation. The memories are organized as a series of 8-bit data words that can be addressed individually or sequentially.

For more information, please see the SFP MSA documentation¹ or Finisar Application Note AN-2030.

Digital diagnostics for the FTLF1318P3BTL are internally calibrated by default.

Please note that evaluation board FDB-1018 is available with Finisar ModDEMO software that allows simple to use communication over the 2-wire serial interface.

IX. Digital Diagnostic Specifications

FTLF1318P3BTL transceivers have internally calibrated digital diagnostics.

Parameter	Symbol	Min	Typ	Max	Units	Ref.
Accuracy						
Internally measured transceiver temperature	DD _{Temperature}			±3	°C	
Internally measured transceiver supply voltage	DD _{Voltage}			±100	mV	
Measured TX bias current	DD _{Bias}			±10	%	1
Measured TX output power	DD _{Tx-Power}			±3	dB	
Measured RX received average optical power	DD _{Rx-Power}			±3	dB	
Dynamic Range for Rated Accuracy						
Internally measured transceiver temperature	DD _{Temperature}	-40		85	°C	
Internally measured transceiver supply voltage	DD _{Voltage}	3.0		3.6	V	
Measured TX bias current	DD _{Bias}	0		60	mA	
Measured TX output power	DD _{Tx-Power}	-11.5		-1	dBm	
Measured RX received average optical power	DD _{Rx-Power}	-23		2	dBm	
Max Reporting Range						
Internally measured transceiver temperature	DD _{Temperature}	-40		125	°C	
Internally measured transceiver supply voltage	DD _{Voltage}	2.8		4.0	V	
Measured TX bias current	DD _{Bias}	0		70	mA	
Measured TX output power	DD _{Tx-Power}	-12.5		0	dBm	
Measured RX received average optical power	DD _{Rx-Power}	-24		3	dBm	

Notes:

- Accuracy of Measured Tx Bias Current is 10% of the actual Bias Current from the laser driver to the laser.

X. Mechanical Specifications

Finisar’s Small Form Factor Pluggable (SFP) transceivers are compatible with the dimensions defined by the SFP Multi-Sourcing Agreement (MSA)³.

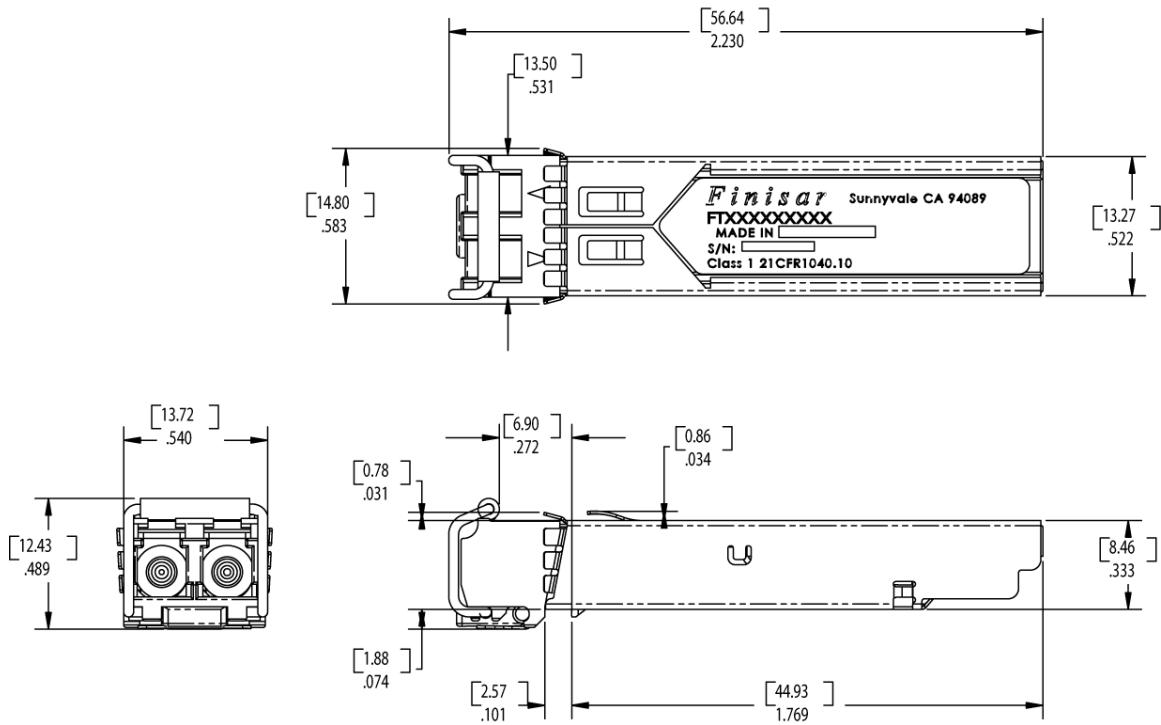

FTLF1318P3BTL

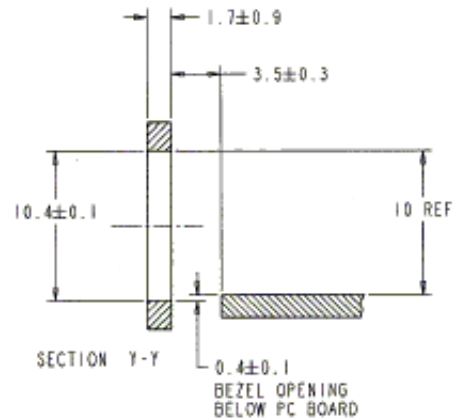
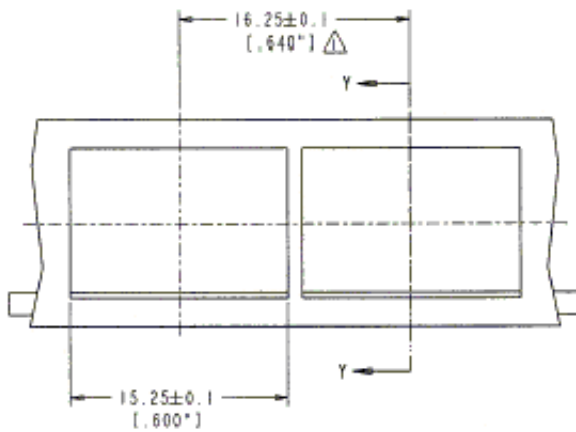
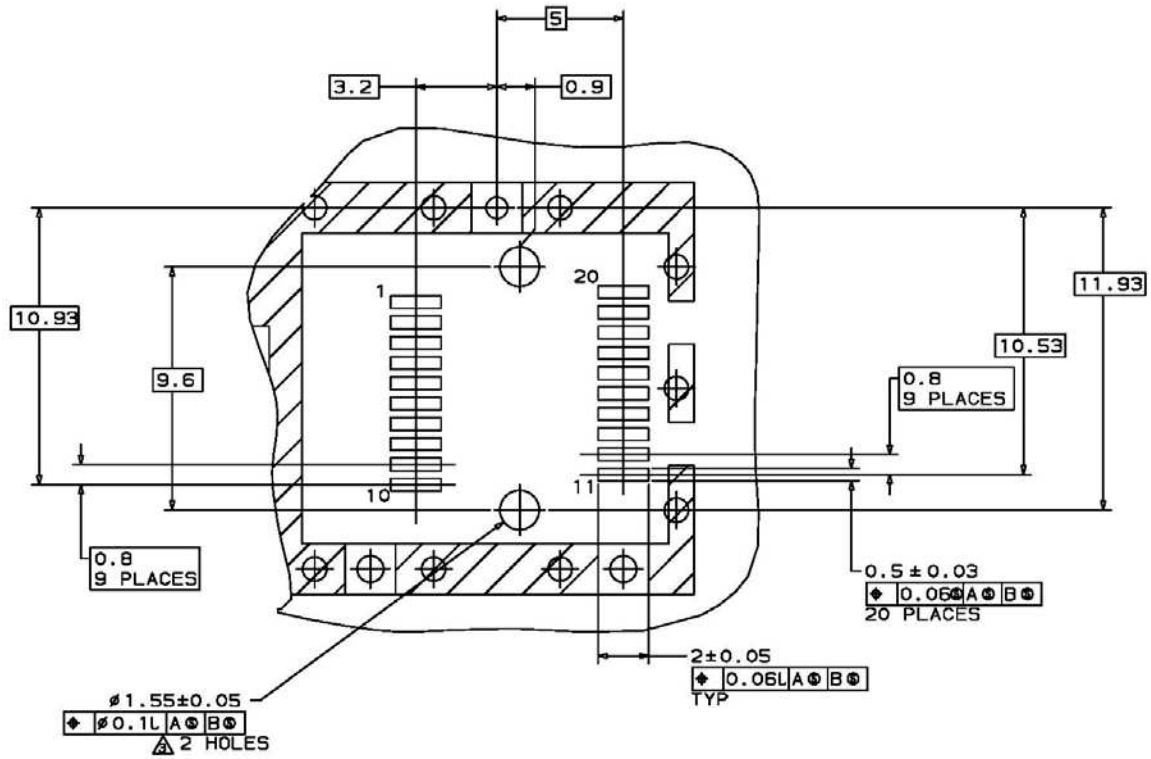

NOTES:

1. MINIMUM PITCH ILLUSTRATED, ENGLISH DIMENSIONS ARE FOR REFERENCE ONLY

2. NOT RECOMMENDED FOR PCI EXPANSION CARD APPLICATIONS

XII. References

1. IEEE Std 802.3, 2002 Edition, Clause 38, PMD Type 1000BASE-LX. IEEE Standards Department, 2002.
2. “Fibre Channel Physical and Signaling Interface (FC-PH, FC-PH2, FC-PH3)”. American National Standard for Information Systems.
3. “Fibre Channel Physical Interface-4 Specification (FC-PI-4 Rev. 8.00)”. American National Standard for Information Technology, May 21, 2008.
4. Small Form-factor Pluggable (SFP) Transceiver Multi-source Agreement (MSA), September 14, 2000.
5. Directive 2011/65/EU of the European Council Parliament and of the Council, “on the restriction of the use of certain hazardous substances in electrical and electronic equipment”. Certain products may use one or more exemptions as allowed by the Directive.

XIII. For More Information

Finisar Corporation
1389 Moffett Park Drive
Sunnyvale, CA 94089-1134
Tel. 1-408-548-1000
Fax 1-408-541-6138
sales@finisar.com
www.finisar.com