



Chipsmall Limited consists of a professional team with an average of over 10 year of expertise in the distribution of electronic components. Based in Hongkong, we have already established firm and mutual-benefit business relationships with customers from,Europe,America and south Asia,supplying obsolete and hard-to-find components to meet their specific needs.

With the principle of “Quality Parts,Customers Priority,Honest Operation,and Considerate Service”,our business mainly focus on the distribution of electronic components. Line cards we deal with include Microchip,ALPS,ROHM,Xilinx,Pulse,ON,Everlight and Freescale. Main products comprise IC,Modules,Potentiometer,IC Socket,Relay,Connector.Our parts cover such applications as commercial,industrial, and automotives areas.

We are looking forward to setting up business relationship with you and hope to provide you with the best service and solution. Let us make a better world for our industry!



Contact us

Tel: +86-755-8981 8866 Fax: +86-755-8427 6832

Email & Skype: info@chipsmall.com Web: www.chipsmall.com

Address: A1208, Overseas Decoration Building, #122 Zhenhua RD., Futian, Shenzhen, China



Product Specification

6.144 Gigabit RoHS Compliant Long-Wavelength SFP+ Transceiver

FTLF1326P3BTL

PRODUCT FEATURES

- Up to 6.144 Gb/s bi-directional data links
- Hot-pluggable SFP+ footprint
- Built-in digital diagnostic functions
- 1310nm Fabry-Perot laser transmitter
- Duplex LC connector
- RoHS compliant and Lead Free
- Up to 2 km at 6.144 Gb/s on 9/125µm SMF
- Metal enclosure, for lower EMI
- Single 3.3V power supply
- Industrial operating temperature range: -40°C to 85°C



APPLICATIONS

- 2.457 Gb/s CPRI
- 4.915 Gb/s CPRI/LTE
- 6.144 Gb/s CPRI/OBSAI/LTE

Finisar's FTLF1326P3BTL SFP+ transceivers are designed for use in Wireless basestation links up to 2 km at 4.915 and 6.144 Gb/s data rates for CPRI, OBSAI, LTE, or other Wireless applications. They are compliant with SFF-8432², SFF-8472 Rev 10.2³, CPRI Rev 4.1⁷, OBSAI Rev V4.1⁸, and applicable portions of FC-PI-4 Rev. 8.00¹; they are also compatible with 1.228 and 2.457 Gb/s data rates for CPRI and applicable portions of SFF-8431 Rev. 3.0⁴. The optical transceivers are compliant per the RoHS Directive 2011/65/EU. See Finisar Application Note AN-2038 for more details.

PRODUCT SELECTION

FTLF1326P3BTL

I. Pin Descriptions

| Pin | Symbol | Name/Description | Ref. |
|-----|--------------------|--|------|
| 1 | V _{EET} | Transmitter Ground (Common with Receiver Ground) | 1 |
| 2 | T _{FAULT} | Transmitter Fault. | 2 |
| 3 | T _{DIS} | Transmitter Disable. Laser output disabled on high or open. | 3 |
| 4 | SDA | 2-wire Serial Interface Data Line (MOD-DEF2) | 4 |
| 5 | SCA | 2-wire Serial Interface Clock (MOD-DEF1) | 4 |
| 6 | MOD_ABS | Module Absent, connected to V _{EET} or V _{EER} | 4 |
| 7 | RS0 | Rx Rate Select: Open or Low = 4.915 to 6.144 Gb/s High = 4.915 to 6.144 Gb/s | 5 |
| 8 | LOS | Loss of Signal indication. Logic 0 indicates normal operation. | 6 |
| 9 | RS1 | Tx Rate Select: Open or Low = 4.915 to 6.144 Gb/s High = 4.915 to 6.144 Gb/s | 5 |
| 10 | V _{EER} | Receiver Ground (Common with Transmitter Ground) | 1 |
| 11 | V _{EER} | Receiver Ground (Common with Transmitter Ground) | 1 |
| 12 | RD- | Receiver Inverted DATA out. AC Coupled | |
| 13 | RD+ | Receiver Non-inverted DATA out. AC Coupled | |
| 14 | V _{EER} | Receiver Ground (Common with Transmitter Ground) | 1 |
| 15 | V _{CCR} | Receiver Power Supply | |
| 16 | V _{CCT} | Transmitter Power Supply | |
| 17 | V _{EET} | Transmitter Ground (Common with Receiver Ground) | 1 |
| 18 | TD+ | Transmitter Non-Inverted DATA in. AC Coupled. | |
| 19 | TD- | Transmitter Inverted DATA in. AC Coupled. | |
| 20 | V _{EET} | Transmitter Ground (Common with Receiver Ground) | 1 |

Notes:

- Circuit ground is internally isolated from chassis ground.
- T_{FAULT} is an open collector/drain output, which should be pulled up with a 4.7k – 10k Ohms resistor on the host board if intended for use. Pull up voltage should be between 2.0V to V_{cc} + 0.3V. A high output indicates a transmitter fault caused by either the TX bias current or the TX output power exceeding the preset alarm thresholds. A low output indicates normal operation. In the low state, the output is pulled to <0.8V.
- Laser output disabled on T_{DIS} >2.0V or open, enabled on T_{DIS} <0.8V.
- Should be pulled up with 4.7k – 10kohms on host board to a voltage between 2.0V and 3.6V. MOD_ABS pulls line low to indicate module is plugged in.
- Rate select can also be set through the 2-wire bus in accordance with SFF-8472 v. 10.2. Rx Rate Select is set at Bit 3, Byte 110, Address A2h. Tx Rate Select is set at Bit 3, Byte 118, Address A2h. Note: writing a “1” selects maximum bandwidth operation. Rate select is the logic OR of the input state of Rate Select Pin and 2-wire bus.
- LOS is open collector output. Should be pulled up with 4.7k – 10kohms on host board to a voltage between 2.0V and 3.6V. Logic 0 indicates normal operation; logic 1 indicates loss of signal.

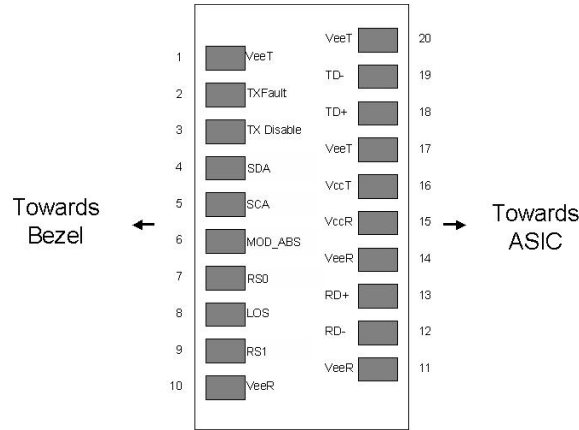

Pinout of Connector Block on Host Board

II. Absolute Maximum Ratings

| Parameter | Symbol | Min | Typ | Max | Unit | Ref. |
|----------------------------|-----------------|------|-----|-----|------|------|
| Maximum Supply Voltage | V _{CC} | -0.5 | | 4.5 | V | |
| Storage Temperature | T _S | -40 | | 100 | °C | |
| Case Operating Temperature | T _{OP} | -40 | | 85 | °C | |
| Relative Humidity | RH | 0 | | 85 | % | 1 |

III. Electrical Characteristics (T_{OP} = -40 to 85 °C, V_{CC} = 3.14 to 3.46 Volts)

| Parameter | Symbol | Min | Typ | Max | Unit | Ref. |
|---|---------------------------------|-----------------|-----|-----------------------|------|------|
| Supply Voltage | V _{CC} | 3.14 | | 3.46 | V | 2 |
| Supply Current | I _{CC} | | | 300 | mA | 2 |
| Transmitter | | | | | | |
| Input differential impedance | R _{in} | | 100 | | Ω | 3 |
| Single ended data input swing | V _{in,pp} | 90 | | 350 | mV | |
| Transmit Disable Voltage | V _D | 2 | | V _{CC} | V | |
| Transmit Enable Voltage | V _{EN} | V _{EE} | | V _{EE} + 0.8 | V | 4 |
| Receiver | | | | | | |
| Single ended data output swing | V _{out,pp} | 275 | | 425 | mV | 5 |
| Data output rise/fall time | t _r , t _f | | | 0.5 | UI | 6,7 |
| LOS Fault | V _{LOS fault} | 2 | | V _{CCHOST} | V | 8 |
| LOS Normal | V _{LOS norm} | V _{EE} | | V _{EE} +0.8 | V | 8 |
| Power Supply Rejection | PSR | 100 | | | mVpp | 9 |
| Note: Jitter values for gamma T and gamma R are controlled by TDP and stressed receiver sensitivity and comply to FC-PI-4 Rev 8.00. | | | | | | |

Notes:

1. Non-condensing.
2. Module power consumption never exceeds 1W.
3. AC coupled.
4. Or open circuit.
5. Into 100 ohm differential termination.
6. 20 – 80 %.
7. 80ps at 6.14Gb/s.
8. LOS is LVTTTL. Logic 0 indicates normal operation; logic 1 indicates no signal detected.
9. All transceiver specifications are compliant with a power supply sinusoidal modulation of 20 Hz to 1.5 MHz up to specified value applied through the power supply filtering network shown on page 23 of the Small Form-factor Pluggable (SFP) Transceiver MultiSource Agreement (MSA)⁶, September 14, 2000. The Power Supply Rejection applies for a supply voltage range of 3.14 to 3.46 V.

IV. Optical Characteristics (T_{OP} = -40 to 85 °C, V_{CC} = 3.14 to 3.46 Volts)

| Parameter | Symbol | Min | Typ | Max | Unit | Ref. |
|---|--------------------|------|------|-------|-------|------|
| Transmitter | | | | | | |
| Output Opt. Power | P _O | -8.4 | -2.5 | +0.5 | dBm | 2 |
| Optical Wavelength | λ | 1260 | | 1350 | nm | 4 |
| Spectral Width | σ | | | | nm | 4 |
| Optical Modulation Amplitude | OMA | 174 | | | μW | 4,5 |
| Transmitter and Dispersion Penalty | TDP | | | 5.2 | dB | 6 |
| RIN | | | | -128 | dB/Hz | |
| Receiver | | | | | | |
| Unstressed Receiver OMA Sensitivity, 6.144 Gb/s | R _{SENSr} | | | 0.042 | mW | 7 |
| Unstressed Receiver OMA Sensitivity, 4.915 Gb/s | R _{SENS4} | | | 0.042 | mW | 7 |
| Average Received Power | R _{XMAX} | | | +0.5 | dBm | |
| Optical Center Wavelength | λ _C | 1260 | | 1360 | nm | |
| Return Loss | | 12 | | | dB | |
| LOS De-Assert | LOS _D | | | -19 | dBm | |
| LOS Assert | LOS _A | -30 | | | dBm | |
| LOS Hysteresis | | 0.5 | | | dB | |

Notes:

1. Class 1 Laser Safety per FDA/CDRH and EN (IEC) 60825 regulations.
2. High Bandwidth Mode. Class 1 Laser Safety per FDA/CDRH and EN (IEC) 60825 regulations.
3. Low Bandwidth Mode. Class 1 Laser Safety per FDA/CDRH and EN (IEC) 60825 regulations.
4. Specified to meet curves in FC-PI-4 Rev 8.00¹ Figures 22, 24 and 25, which allow trade-off between wavelength, spectral width and OMA.
5. Equivalent extinction ratio specification for Fibre Channel. Allows smaller ER at higher average power.
6. Jitter values for gamma T and gamma R are controlled by TDP and stressed receiver sensitivity according to FC-PI-4 Rev. 8.00.
7. Measured with conformance signals defined in FC-PI-4 Rev. 8.00 specifications. Value in OMA. Measured with PRBS 2⁷-1 at 10⁻¹² BER.

V. General Specifications

| Parameter | Symbol | Min | Typ | Max | Units | Ref. |
|--|------------|-------|-----|------------|--------|------|
| Data Rate | BR | 1.228 | | 6.144 | Gb/sec | 1,2 |
| Bit Error Rate | BER | | | 10^{-12} | | 3 |
| Max. Supported Link Length on 9/125 μ m SMF, 4.915, 6.144 Gb/s | L_{MAX1} | | 2 | | km | |

Notes:

1. 4.915/6.144 Gb/s CPRI/OBSAI/LTE compliant.
2. 1.228/2.457 Gb/s compatible (data rate is supported but not optimized for Rx bandwidth).
3. Tested with a PRBS 2^7-1 test pattern.

VI. Environmental Specifications

These Finisar 1310nm Extended Temperature SFP+ transceivers have an operating temperature range from -40 to +85°C case temperature.

| Parameter | Symbol | Min | Typ | Max | Units | Ref. |
|----------------------------|-----------|-----|-----|-----|-------|------|
| Case Operating Temperature | T_{op} | -40 | | 85 | °C | |
| Storage Temperature | T_{sto} | -40 | | 100 | °C | |

VII. Regulatory Compliance

Finisar transceivers are Class 1 Laser Products and comply with US FDA regulations. These products are certified by TÜV and CSA to meet the Class 1 eye safety requirements of EN (IEC) 60825 and the electrical safety requirements of EN (IEC) 60950. Copies of certificates are available at Finisar Corporation upon request.

VIII. Digital Diagnostic Functions

Finisar FTLF1326P3BTL SFP+ transceivers support the 2-wire serial communication protocol as defined in the SFP MSA⁶. It is very closely related to the E²PROM defined in the GBIC standard, with the same electrical specifications.

The standard SFP serial ID provides access to identification information that describes the transceiver's capabilities, standard interfaces, manufacturer, and other information.

Additionally, Finisar SFP transceivers provide a unique enhanced digital diagnostic monitoring interface, which allows real-time access to device operating parameters such as transceiver temperature, laser bias current, transmitted optical power, received optical power and transceiver supply voltage. It also defines a sophisticated system of alarm and warning flags, which alerts end-users when particular operating parameters are outside of a factory set normal range.

The SFP MSA defines a 256-byte memory map in E²PROM that is accessible over a 2-wire serial interface at the 8 bit address 1010000X (A0h). The digital diagnostic monitoring interface makes use of the 8 bit address 1010001X (A2h), so the originally defined serial ID memory map remains unchanged. The interface is identical to, and is thus fully backward compatible with both the GBIC Specification and the SFP Multi Source Agreement. The complete interface is described in Finisar Application Note AN-2030: "Digital Diagnostics Monitoring Interface for SFP Optical Transceivers".

The operating and diagnostics information is monitored and reported by a Digital Diagnostics Transceiver Controller (DDTC) inside the transceiver, which is accessed through a 2-wire serial interface. When the serial protocol is activated, the serial clock signal (SCL, Mod Def 1) is generated by the host. The positive edge clocks data into the SFP transceiver into those segments of the E²PROM that are not write-protected. The negative edge clocks data from the SFP transceiver. The serial data signal (SDA, Mod Def 2) is bi-directional for serial data transfer. The host uses SDA in conjunction with SCL to mark the start and end of serial protocol activation. The memories are organized as a series of 8-bit data words that can be addressed individually or sequentially.

For more information, please see the SFP MSA documentation^{3,6} or Finisar Application Note AN-2030.

FTLF1326P3BTL transceivers can be used in host systems that require either internally or externally calibrated digital diagnostics.

Please note that evaluation board FDB-1018 is available with Finisar ModDEMO software that allows simple to use communication over the 2-wire serial interface.

IX. Mechanical Specifications

Finisar’s FTLF1326P3BTL SFP+ transceivers are compatible with the SFF-8432² specification for improved pluggable form factor.

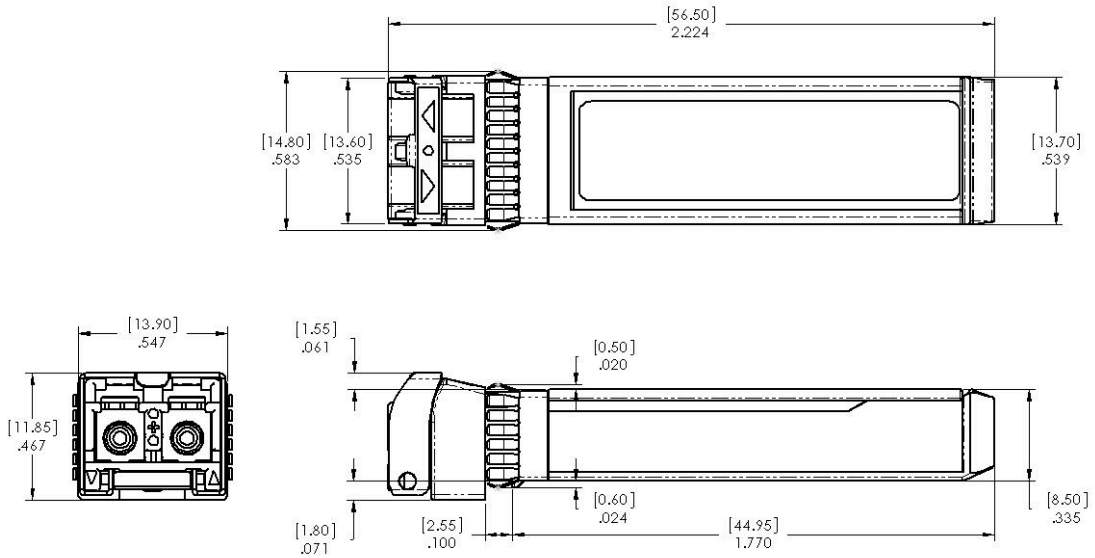

FTLF1326P3BTL

X. PCB Layout and Bezel Recommendations

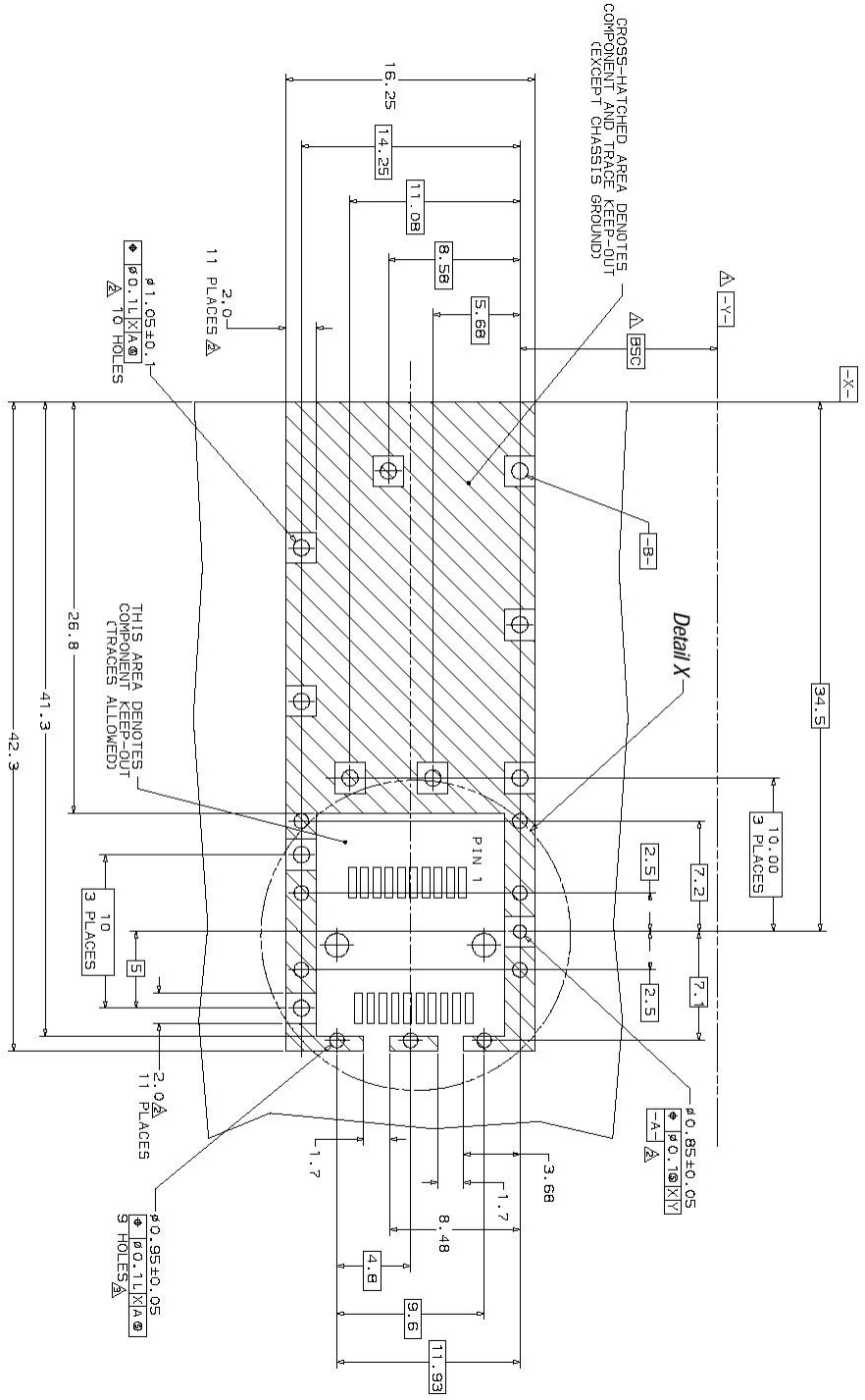

- Δ Datum and Basic Dimension Established by Customer
- ∇ Pads and Vias are Chassis Ground, 11 Places
- ∇ Through Holes are Unplated

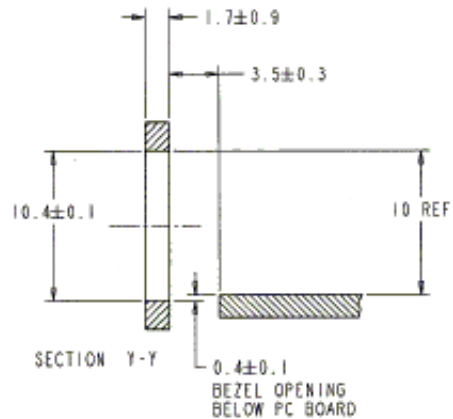
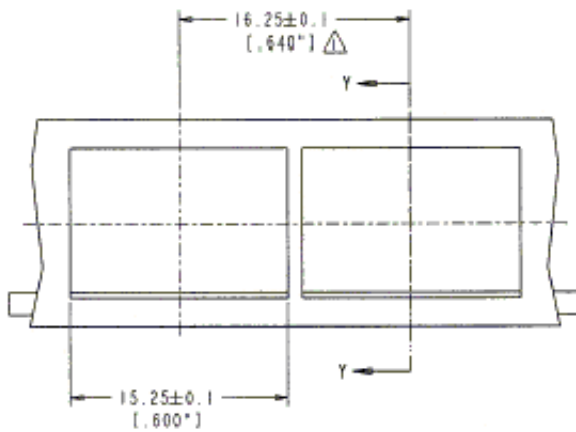
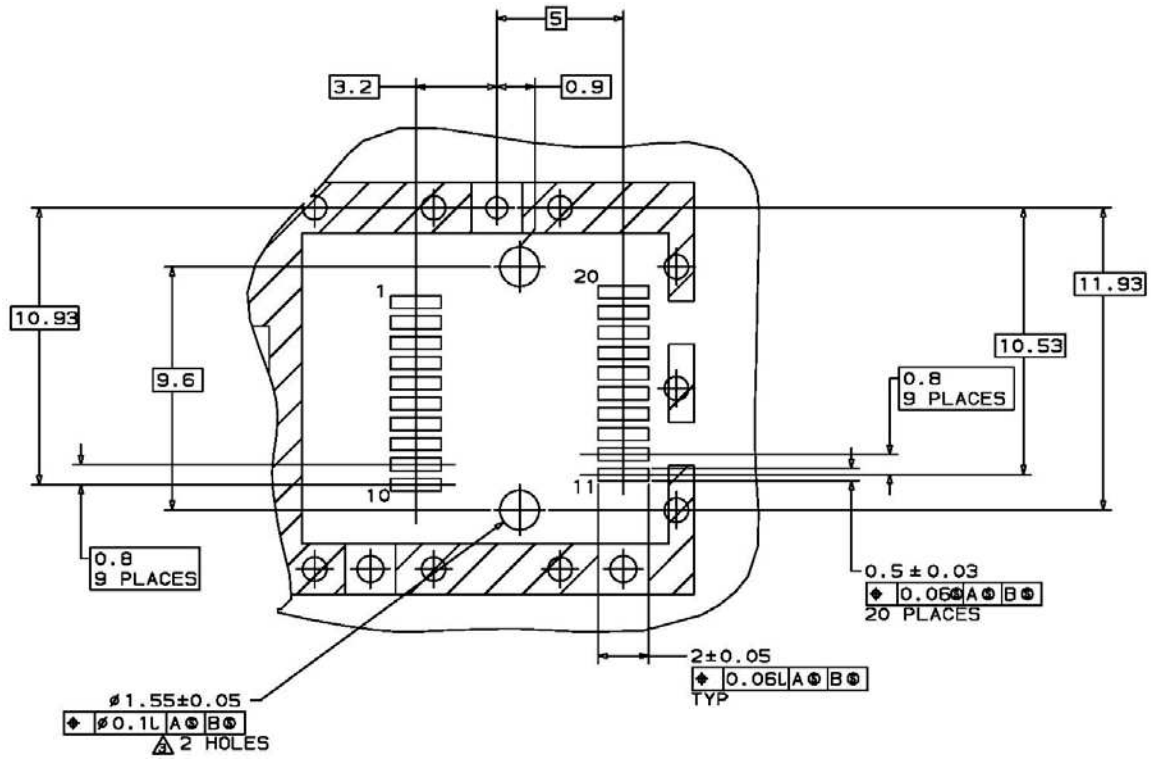

NOTES:

- 1. \triangle MINIMUM PITCH ILLUSTRATED, ENGLISH DIMENSIONS ARE FOR REFERENCE ONLY
- 2. NOT RECOMMENDED FOR PCI EXPANSION CARD APPLICATIONS

XI. References

1. “Fibre Channel Physical Interface-4 Specification (FC-PI-4 Rev. 8.00)”. American National Standard for Information Technology, May 21, 2008.
2. “Improved Pluggable Formfactor”, SFF Document Number SFF-8432, Revision 5.0, July 16, 2007.
3. “Digital Monitoring Interface for Optical Transceivers”, SFF Document Number SFF-8472, Revision 10.2, June 1, 2007.
4. “Enhanced Specification for 8.5 and 10 Gigabit Small Form Factor Pluggable Module ‘SFP+ ’”, SFF Document Number SFF-8431, Revision 3.0, May 8, 2008.
5. Directive 2011/65/EU of the European Council Parliament and of the Council, “on the restriction of the use of certain hazardous substances in electrical and electronic equipment”. Certain products may use one or more exemptions as allowed by the Directive.
6. Small Form Factor Pluggable (SFP) Transceiver Multi-source Agreement (MSA), September 14, 2000.
7. “CPRI Specification V4.1”. Common Public Radio Interface. February 18, 2009.
8. “Reference Point 3 Specification”. Open Base Station Architecture Initiative. July 2008.

XII. For More Information

Finisar Corporation
1389 Moffett Park Drive
Sunnyvale, CA 94089-1134
Tel. 1-408-548-1000
Fax 1-408-541-6138
sales@finisar.com
www.finisar.com

Data subject to change without notice.