



Chipsmall Limited consists of a professional team with an average of over 10 year of expertise in the distribution of electronic components. Based in Hongkong, we have already established firm and mutual-benefit business relationships with customers from,Europe,America and south Asia,supplying obsolete and hard-to-find components to meet their specific needs.

With the principle of “Quality Parts,Customers Priority,Honest Operation,and Considerate Service”,our business mainly focus on the distribution of electronic components. Line cards we deal with include Microchip,ALPS,ROHM,Xilinx,Pulse,ON,Everlight and Freescale. Main products comprise IC,Modules,Potentiometer,IC Socket,Relay,Connector.Our parts cover such applications as commercial,industrial, and automotives areas.

We are looking forward to setting up business relationship with you and hope to provide you with the best service and solution. Let us make a better world for our industry!



Contact us

Tel: +86-755-8981 8866 Fax: +86-755-8427 6832

Email & Skype: info@chipsmall.com Web: www.chipsmall.com

Address: A1208, Overseas Decoration Building, #122 Zhenhua RD., Futian, Shenzhen, China



Product Specification

RoHS-6 Compliant

I-Temp 40km Multi-Rate XFP Optical Transceiver

FTLX1612M3BTL

PRODUCT FEATURES

- Supports 9.95Gb/s to 11.3Gb/s bit rates
- Hot-pluggable XFP footprint
- Maximum link length of 40km
- RoHS-6 Compliant (lead-free)
- Temperature-stabilized 1550nm 800 ps/nm EML transmitter
- 3.3V and 5V power supplies required
- Duplex LC connector
- Power dissipation < 3.5W
- Built-in digital diagnostic functions
- Industrial temperature range: -40°C to 85°C
- Bail release mechanism
- Reference clock not required



APPLICATIONS

- SONET OC-192 IR-2
SDH STM S-64.2b
SONET OC-192 IR-3
SDH STM S-64.3b
ITU-T G.709
- 10GBASE-ER/EW
10GBASE-ER/EW + FEC
- 40km 10G Fibre Channel
40km 10G Fibre Channel + FEC

Finisar's industrial temperature 40km FTLX1612M3BTL Small Form Factor 10Gb/s XFP transceivers comply with the current XFP Multi-Source Agreement (MSA) Specification¹. They comply with SONET OC-192 IR-2, OC-192 IR-3, SDH STM S-64.2b, STM S-64.3b as well as with 10-Gigabit Ethernet 10GBASE-ER/EW per IEEE 802.3ae and 40km 10G Fibre Channel applications. Digital diagnostics functions are available via a 2-wire serial interface, as specified in the XFP MSA. The optical transceiver is compliant per the RoHS Directive 2011/65/EU³. See Finisar Application Note AN-2038 for more details.⁴

PRODUCT SELECTION

FTLX1612M3BTL

I. Pin Descriptions

Pin	Logic	Symbol	Name/Description	Ref.
1		GND	Module Ground	1
2		VEE5	Optional -5.2 Power Supply – Not Required	
3	LVTTL-I	Mod-Desel	Module De-select; When held low allows the module to respond to 2-wire serial interface commands	
4	LVTTL-O	$\overline{\text{Interrupt}}$	Interrupt (bar); Indicates presence of an important condition which can be read over the serial 2-wire interface	2
5	LVTTL-I	TX_DIS	Transmitter Disable; Transmitter laser source turned off	
6		VCC5	+5 Power Supply	
7		GND	Module Ground	1
8		VCC3	+3.3V Power Supply	
9		VCC3	+3.3V Power Supply	
10	LVTTL-I	SCL	Serial 2-wire interface clock	2
11	LVTTL-I/O	SDA	Serial 2-wire interface data line	2
12	LVTTL-O	Mod_Abs	Module Absent; Indicates module is not present. Grounded in the module.	2
13	LVTTL-O	Mod_NR	Module Not Ready; Finisar defines it as a logical OR between RX_LOS and Loss of Lock in TX/RX.	2
14	LVTTL-O	RX_LOS	Receiver Loss of Signal indicator	2
15		GND	Module Ground	1
16		GND	Module Ground	1
17	CML-O	RD-	Receiver inverted data output	
18	CML-O	RD+	Receiver non-inverted data output	
19		GND	Module Ground	1
20		VCC2	+1.8V Power Supply – Not Required	
21	LVTTL-I	P_Down/RST	Power Down; When high, places the module in the low power stand-by mode and on the falling edge of P_Down initiates a module reset Reset; The falling edge initiates a complete reset of the module including the 2-wire serial interface, equivalent to a power cycle.	
22		VCC2	+1.8V Power Supply – Not Required	
23		GND	Module Ground	1
24	PECL-I	RefCLK+	Reference Clock non-inverted input, AC coupled on the host board – Not required	
25	PECL-I	RefCLK-	Reference Clock inverted input, AC coupled on the host board – Not required	
26		GND	Module Ground	1
27		GND	Module Ground	1
28	CML-I	TD-	Transmitter inverted data input	
29	CML-I	TD+	Transmitter non-inverted data input	
30		GND	Module Ground	1

Notes:

1. Module circuit ground is isolated from module chassis ground within the module.
2. Open collector; should be pulled up with 4.7k – 10kohms on host board to a voltage between 3.15V and 3.6V.

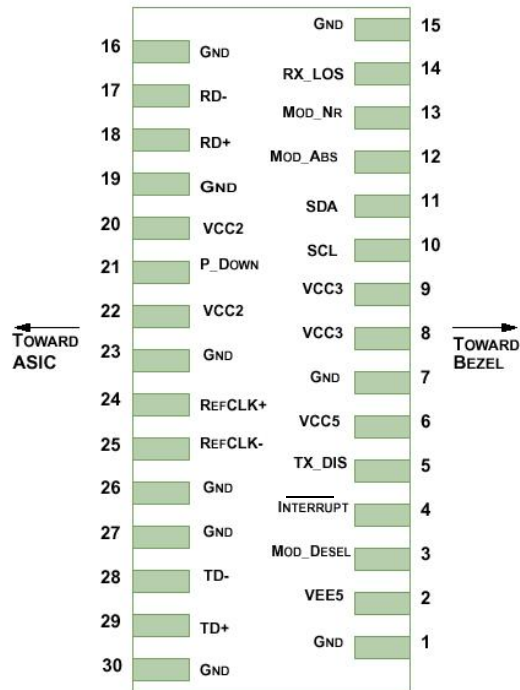

Diagram of Host Board Connector Block Pin Numbers and Names

II. Absolute Maximum Ratings

Parameter	Symbol	Min	Typ	Max	Unit	Ref.
Maximum Supply Voltage 1	Vcc3	-0.5		4.0	V	
Maximum Supply Voltage 2	Vcc5	-0.5		6.0	V	
Storage Temperature	T _S	-40		85	°C	
Case Operating Temperature	T _{OP}	-40		85	°C	

III. Electrical Characteristics ($T_{OP} = -40$ to 85 °C, $V_{CC5} = 4.75$ to 5.25 Volts)

Parameter	Symbol	Min	Typ	Max	Unit	Ref.	
Main Supply Voltage	V _{cc5}	4.75		5.25	V		
Supply Voltage #2	V _{cc3}	3.13		3.45	V		
Supply Current – V _{cc5} supply	I _{cc5}			350	mA		
Supply Current – V _{cc3} supply	I _{cc3}			700	mA		
Module total power	P			3.5	W	1	
Transmitter							
Input differential impedance	R _{in}		100		Ω	2	
Differential data input swing	V _{in,pp}	120		820	mV		
Transmit Disable Voltage	V _D	2.0		V _{cc}	V	3	
Transmit Enable Voltage	V _{EN}	GND		GND+ 0.8	V		
Transmit Disable Assert Time				10	us		
Receiver							
Differential data output swing	V _{out,pp}	340	650	850	mV	4	
Data output rise time	t _r			38	ps	5	
Data output fall time	t _f			38	ps	5	
LOS Fault	V _{LOS fault}	V _{cc} – 0.5		V _{ccHOST}	V	6	
LOS Normal	V _{LOS norm}	GND		GND+0.5	V	6	
Power Supply Rejection	PSR	See Note 6 below					7

Notes:

- Maximum total power value is specified across the full temperature and voltage range.
- After internal AC coupling.
- Or open circuit.
- Into 100 ohms differential termination.
- 20 – 80 %
- Loss Of Signal is open collector to be pulled up with a 4.7k – 10kohm resistor to 3.15 – 3.6V. Logic 0 indicates normal operation; logic 1 indicates no signal detected.
- Per Section 2.7.1. in the XFP MSA Specification¹.

IV. Optical Characteristics ($T_{OP} = -40$ to 85 °C, $V_{CC5} = 4.75$ to 5.25 Volts)

Please note that the Transmitter of the FTLX1612M3BTL becomes operational within 5 seconds of power-up. This is due to the time required for the EML to reach its optimum operating temperature.

Parameter	Symbol	Min	Typ	Max	Unit	Ref.
Transmitter						
Output Opt. Pwr: 9/125 SMF	P_{OUT}	-1		+2	dBm	1
Optical Extinction Ratio	ER	8.2			dB	1
Optical Modulation Amplitude	OMA	-2.1			dBm	2
Center Wavelength	λ_C	1530		1565	nm	
Transmitter Dispersion Penalty (@ 800 ps/nm)	TDP			2	dB	
Sidemode Supression ratio	SSR_{min}	30			dB	
SONET Tx Jitter Generation (peak-to-peak)	Tx_j			0.1	UI	3
Tx Jitter Generation (RMS)	Tx_{jRMS}			0.01	UI	4
Relative Intensity Noise	RIN			-130	dB/Hz	
Receiver						
Receiver Sensitivity @ 9.95Gb/s to 10.7Gb/s	R_{SENS1}			-16	dBm	5
Receiver Sensitivity @ 11.1Gb/s to 11.3Gb/s	R_{SENS2}			-15	dBm	
Stressed Receiver Sensitivity (OMA) @ 11.1Gb/s	R_{SENS2}			-11.3	dBm	6
Maximum Input Power	P_{MAX}	-1			dBm	
Optical Center Wavelength	λ_C	1270		1600	nm	
Receiver Reflectance	R_{TX}			-27	dB	
Path penalty at 40km (up to 10.7Gb/s)				2	dB	7
LOS De-Assert	LOS_D			-22	dBm	
LOS Assert	LOS_A	-28			dBm	
LOS Hysteresis		0.5			dB	

Notes:

- ER = 8.2dB minimum for data rates 9.9Gb/s to 10.7Gb/s.
- Guaranteed minimum OMA for 9.9Gb/s - 11.3 Gb/s.
- Measured with a host jitter of 50 mUI peak-to-peak per Telcordia GR-253.
- Measured with a host jitter of 7 mUI RMS.
- Measured with worst ER; BER < 10^{-12} ; PRBS31. Equivalent to -14.3 dBm OMA at ER = 8.2 dB.
- Per IEEE 802.3ae. Equivalent to -14.3 dBm average power at Infinite ER.
- Dispersion penalty is measured in loopback using 18 ps/(nm*km) fiber (SMF-28). Path penalty is 2dB at 10.7Gb/s.

V. General Specifications

Parameter	Symbol	Min	Typ	Max	Units	Ref.
Bit Rate	BR	9.95		11.3	Gb/s	1
Bit Error Ratio	BER			10^{-12}		2
Max. Supported Link Length	L_{MAX}		40		km	1

Notes:

- SONET OC-192 IR-2, OC-192 IR-3, 10GBASE-ER/EW, 10G Fibre Channel, ITU-T G.709, 10GBASE-ER/EW + FEC, 10G Fibre Channel + FEC
- Tested with a $2^{31} - 1$ PRBS

VI. Environmental Specifications

The FTLX1612M3BTL transceiver has an operating case temperature range from -40°C to $+85^{\circ}\text{C}$.

Parameter	Symbol	Min	Typ	Max	Units	Ref.
Case Operating Temperature	T_{op}	-40		85	$^{\circ}\text{C}$	
Storage Temperature	T_{sto}	-40		85	$^{\circ}\text{C}$	

VII. Regulatory Compliance

Finisar XFP transceivers are Class 1 Laser Products. They are certified per the following standards:

Feature	Agency	Standard	Certificate Number
Laser Eye Safety	FDA/CDRH	CDRH 21 CFR 1040 and Laser Notice 50	9210176-77
Laser Eye Safety	TÜV	EN 60825-1: 2007, EN60825-2:2004+A1 IEC 60825-1: 2007 (2 nd Edition) IEC 60825-2: 2010 (3 rd Edition)	72101686
Electrical Safety	TÜV	EN 60950:2006+A11	72101686
Electrical Safety	UL/CSA	CLASS 3862.07 CLASS 3862.87	2283290

Copies of the referenced certificates are available at Finisar Corporation upon request.

VIII. Digital Diagnostics Functions

As defined by the XFP MSA¹, Finisar XFP transceivers provide digital diagnostic functions via a 2-wire serial interface, which allows real-time access to the following operating parameters:

- Transceiver temperature
- Laser bias current
- Transmitted optical power
- Received optical power
- Transceiver supply voltage

It also provides a sophisticated system of alarm and warning flags, which may be used to alert end-users when particular operating parameters are outside of a factory-set normal range.

The operating and diagnostics information is monitored and reported by a Digital Diagnostics Transceiver Controller (DDTC) inside the transceiver, which is accessed through the 2-wire serial interface. When the serial protocol is activated, the serial clock signal (SCL pin) is generated by the host. The positive edge clocks data into the XFP transceiver into those segments of its memory map that are not write-protected. The negative edge clocks data from the XFP transceiver. The serial data signal (SDA pin) is bi-directional for serial data transfer. The host uses SDA in conjunction with SCL to mark the start and end of serial protocol activation. The memories are organized as a series of 8-bit data words that can be addressed individually or sequentially. The 2-wire serial interface provides sequential or random access to the 8 bit parameters, addressed from 000h to the maximum address of the memory.

For more detailed information, including memory map definitions, please see the XFP MSA documentation¹.

IX. Mechanical Specifications

Finisar's XFP transceivers are compliant with the dimensions defined by the XFP Multi-Sourcing Agreement (MSA).

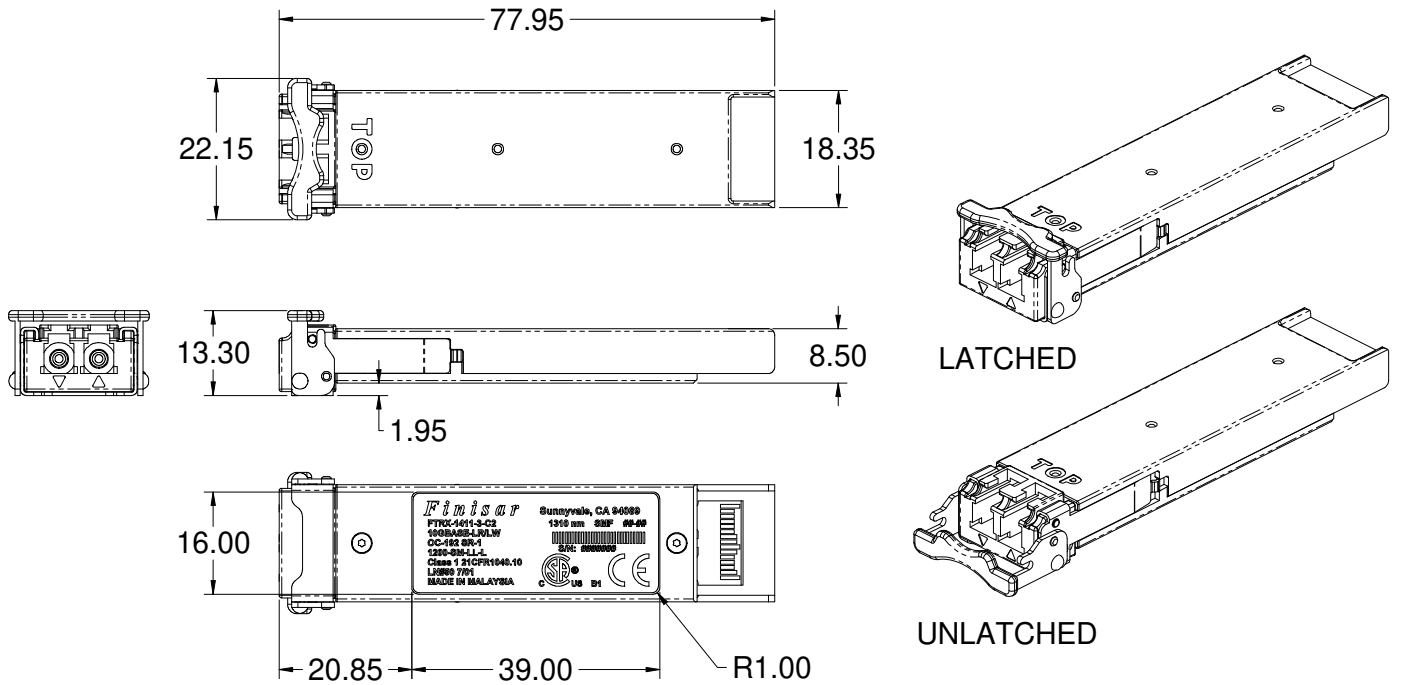

XFP Transceiver (dimensions are in mm)

X. PCB Layout and Bezel Recommendations

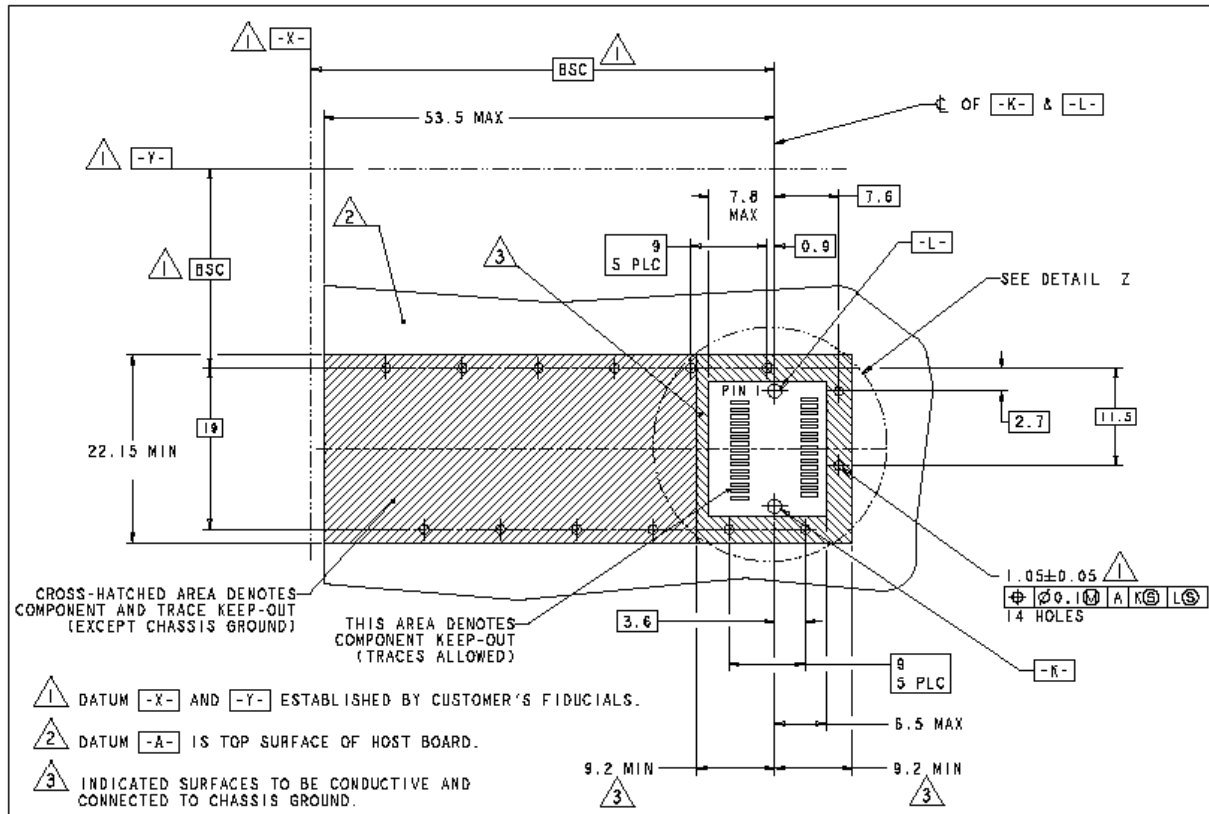

XFP Host Board Mechanical Layout (dimensions are in mm)

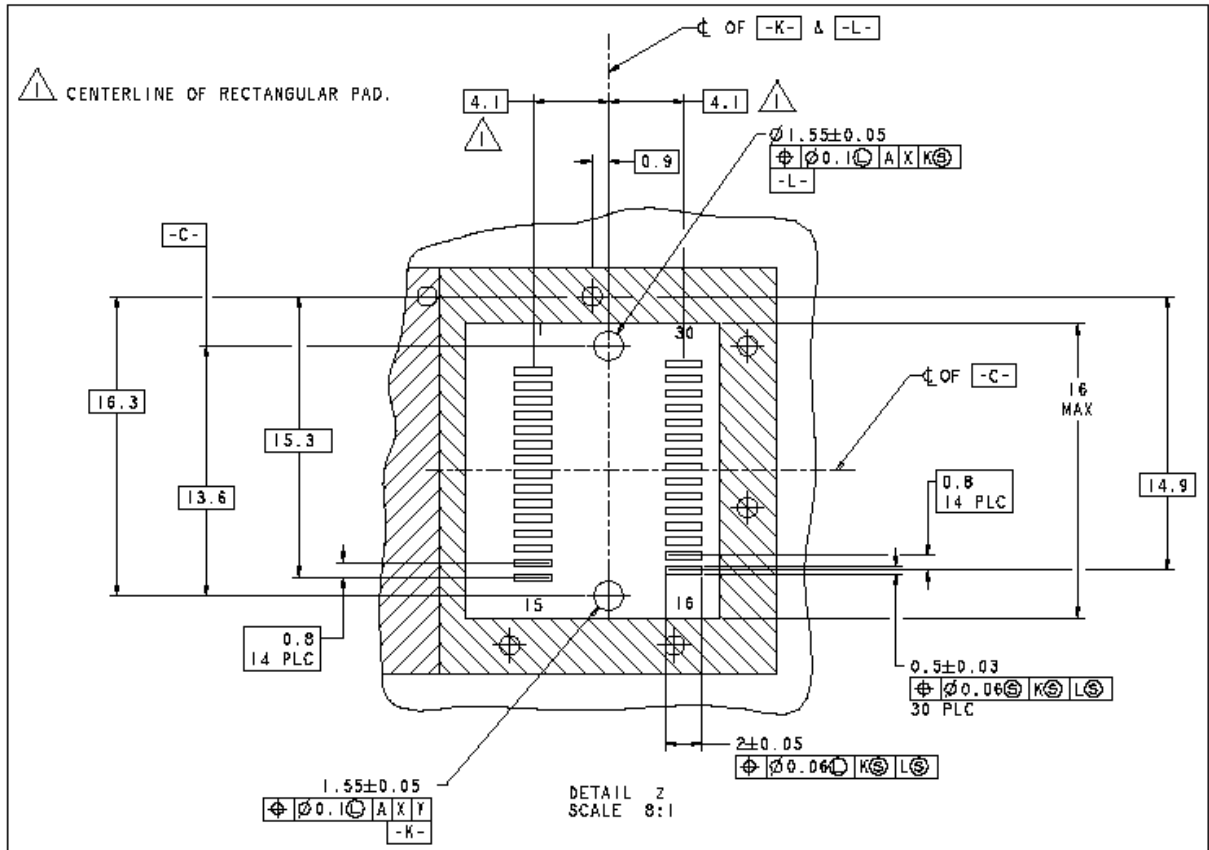

XFP Detail Host Board Mechanical Layout (dimensions are in mm)

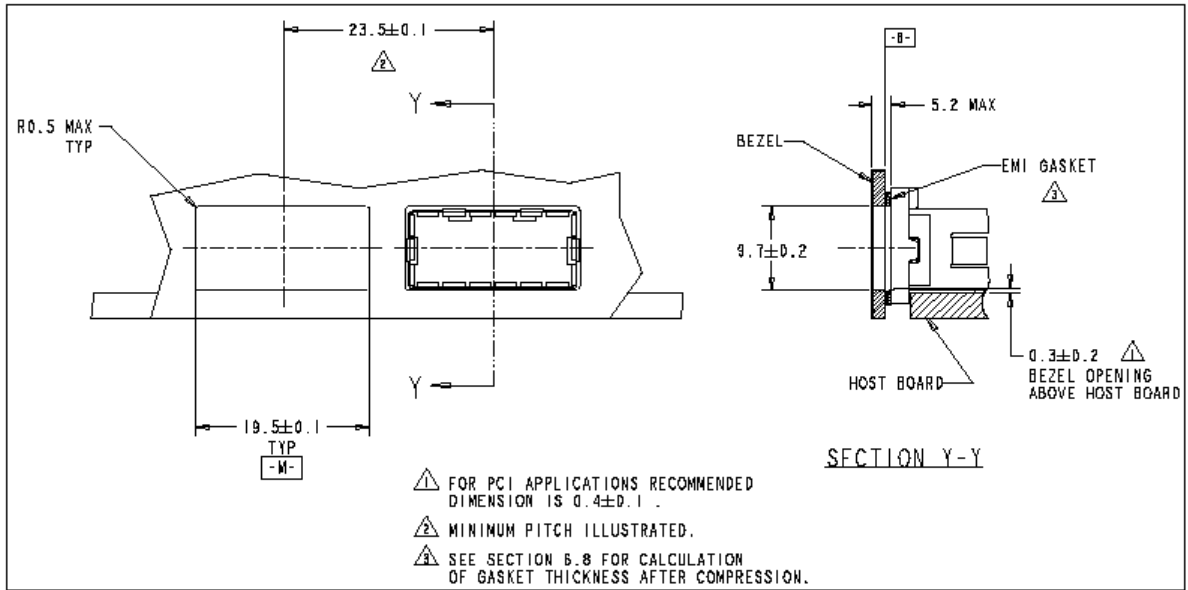

XFP Recommended Bezel Design (dimensions are in mm)

XI. References

1. 10 Gigabit Small Form Factor Pluggable Module (XFP) Multi-Source Agreement (MSA), Rev 4.5 – August 2005. Documentation is currently available at <http://www.xfpmsa.org/>
2. Application Note AN-2035: “Digital Diagnostic Monitoring Interface for XFP Optical Transceivers” – Finisar Corporation, December 2003
3. Directive 2011/65/EU of the European Council Parliament and of the Council, “on the restriction of the use of certain hazardous substances in electrical and electronic equipment”
4. “Application Note AN-2038: Finisar Implementation Of RoHS Compliant Transceivers”

XII. Revision History

Revision	Date	Description
A1	3/15/2007	<ul style="list-style-type: none"> • Document created.
A2	1/21/2008	<ul style="list-style-type: none"> • Removed 1.8V power supply and reference clock requirements. • Added receiver sensitivity at 11.3Gb/s.
C1	11/22/2010	<ul style="list-style-type: none"> • Updated Laser Safety Certificates
D1	8/31/2015	<ul style="list-style-type: none"> • Updated logo and RoHS statement

XIII. For More Information

Finisar Corporation
 1389 Moffett Park Drive
 Sunnyvale, CA 94089-1133
 Tel. 1-408-548-1000
 Fax 1-408-541-6138
sales@finisar.com
www.finisar.com