



Chipsmall Limited consists of a professional team with an average of over 10 year of expertise in the distribution of electronic components. Based in Hongkong, we have already established firm and mutual-benefit business relationships with customers from,Europe,America and south Asia,supplying obsolete and hard-to-find components to meet their specific needs.

With the principle of "Quality Parts,Customers Priority,Honest Operation,and Considerate Service",our business mainly focus on the distribution of electronic components. Line cards we deal with include Microchip,ALPS,ROHM,Xilinx,Pulse,ON,Everlight and Freescale. Main products comprise IC,Modules,Potentiometer,IC Socket,Relay,Connector.Our parts cover such applications as commercial,industrial, and automotives areas.

We are looking forward to setting up business relationship with you and hope to provide you with the best service and solution. Let us make a better world for our industry!



Contact us

Tel: +86-755-8981 8866 Fax: +86-755-8427 6832

Email & Skype: info@chipsmall.com Web: www.chipsmall.com

Address: A1208, Overseas Decoration Building, #122 Zhenhua RD., Futian, Shenzhen, China



Product Specification

10Gb/s, 40km Single Mode, Multi-Rate SFP+ Transceiver

FTLX1672M3BNL

PRODUCT FEATURES

- Hot-pluggable SFP+ footprint
- Supports 8.5 and 9.95 to 11.3 Gb/s
- 40km link length (800ps/nm)
- -5/85°C case temperature range
- Internal transmitter/receiver CDR
- low power consumption
- Cooled 1550nm EML laser
- Limiting electrical interface receiver
- Duplex LC connector
- Built-in digital diagnostic functions
- RoHS-6 compliant (lead-free)



APPLICATIONS

- SONET OC-192 IR-2/-3
- SDH STM-64.2b/3b
- OTN G959.1 P1S1-2D2b
- OTN G.709 OTU1e/2/2e FEC bit rates
- 10GBASE-ER/EW
- 8.5/10G Fibre Channel

Finisar's FTLX1672M3BNL transceivers are Enhanced Small Form Factor Pluggable SFP+ transceivers designed for use in 10-Gigabit multi-rate links up to 40km of G.652 single mode fiber. They are compliant with SFF-8431¹, SFF-8432², SONET OC-192 IR-2R/3R, SDH STM-64.2b/3b, OTN P1S1-2D2b, 10GBASE-ER/EW and support 8.5G and 10G Fibre Channel. The transceivers use internal clock and data recovery (CDR) IC's for the transmitter and the receiver. This guarantees compliance with the SONET/SDH jitter requirements and it can be used to set the electrical interface to be XFI-compliant.

Digital diagnostics functions are available via a 2-wire serial interface, as specified in SFF-8472³. The optical transceiver is compliant per the RoHS Directive 2011/65/EU⁴. See Finisar Application Note AN-2038 for more details⁵.

PRODUCT SELECTION

| |
|----------------------|
| FTLX1672M3BNL |
|----------------------|

I. Pin Descriptions

| Pin | Symbol | Name/Description | Ref. |
|-----|--------------------|--|------|
| 1 | V _{EET} | Transmitter Ground | 1 |
| 2 | T _{FAULT} | Transmitter Fault | 2 |
| 3 | T _{DIS} | Transmitter Disable. Laser output disabled on high or open. | 3 |
| 4 | SDA | 2-wire Serial Interface Data Line | 2 |
| 5 | SCL | 2-wire Serial Interface Clock Line | 2 |
| 6 | MOD_ABS | Module Absent. Grounded within the module | 2 |
| 7 | RS0 | Rate Select 0. | 4 |
| 8 | RX_LOS | Loss of Signal indication. Logic 0 indicates normal operation. | 5 |
| 9 | RS1 | Rate Select 1. | 4 |
| 10 | V _{EER} | Receiver Ground | 1 |
| 11 | V _{EER} | Receiver Ground | 1 |
| 12 | RD- | Receiver Inverted DATA out. AC Coupled. | |
| 13 | RD+ | Receiver Non-inverted DATA out. AC Coupled. | |
| 14 | V _{EER} | Receiver Ground | 1 |
| 15 | V _{CCR} | Receiver Power Supply | 6 |
| 16 | V _{CCT} | Transmitter Power Supply | 6 |
| 17 | V _{EET} | Transmitter Ground | 1 |
| 18 | TD+ | Transmitter Non-Inverted DATA in. AC Coupled. | |
| 19 | TD- | Transmitter Inverted DATA in. AC Coupled. | |
| 20 | V _{EET} | Transmitter Ground | 1 |

Notes:

- Circuit ground is internally isolated from chassis ground.
- T_{FAULT} is an open collector/drain output, which should be pulled up with a 4.7k – 10k Ohms resistor on the host board if intended for use. Pull up voltage should be between 2.0V to V_{cc} + 0.3V. A high output indicates a transmitter fault caused by either the TX bias current or the TX output power exceeding the preset alarm thresholds. A low output indicates normal operation. In the low state, the output is pulled to <0.8V.
- Laser output disabled on T_{DIS} >2.0V or open, enabled on T_{DIS} <0.8V.
- Internally pulled down per SFF-8431 Rev 4.1. See Sec. X of this datasheet for the logic table to use for the internal CDRs locking modes.
- LOS is open collector output. Should be pulled up with 4.7k – 10kΩ on host board to a voltage between 2.0V and 3.6V. Logic 0 indicates normal operation; logic 1 indicates loss of signal.
- Internally connected

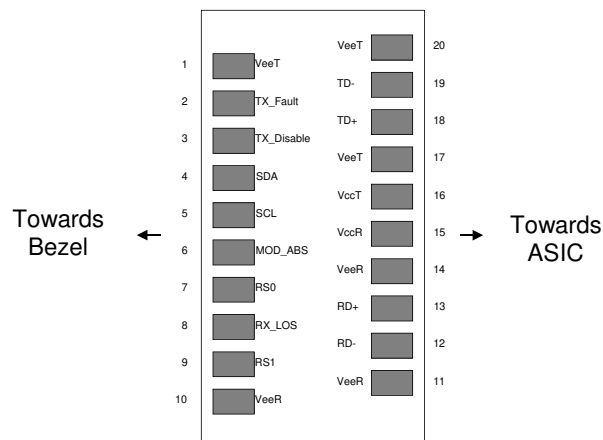

Figure 1. Diagram of Host Board Connector Block Pin Numbers and Names.

II. Absolute Maximum Ratings

Exceeding the limits below may damage the transceiver module permanently.

| Parameter | Symbol | Min | Typ | Max | Unit | Ref. |
|-----------------------------------|----------------------|------|-----|-----|------|------|
| Maximum Supply Voltage | V _{cc} | -0.5 | | 4.0 | V | |
| Storage Temperature | T _s | -40 | | 85 | °C | |
| Relative Humidity | RH | 0 | | 85 | % | 1 |
| Receiver Optical Damage Threshold | R _{XDamage} | 5 | | | dBm | |

Notes:

1. Non-condensing

III. Electrical Characteristics (T_{OP} = -5 to 85 °C)

| Parameter | Symbol | Min | Typ | Max | Unit | Ref. |
|---------------------------------------|------------------------------------|----------------------|------|-----------------|------|------|
| Supply Voltage | V _{cc} | 3.14 | 3.30 | 3.46 | V | |
| Transmitter (Tx) | | | | | | |
| Input differential impedance | R _{in} | 80 | 100 | 120 | Ω | |
| Differential data input swing | V _{in,pp} | 120 | | 850 | mV | 1 |
| Transmit Disable Voltage | V _D | V _{cc} -0.8 | | V _{cc} | V | |
| Transmit Enable Voltage | V _{EN} | 0 | | 0.8 | V | |
| Receiver (Rx) | | | | | | |
| Output differential impedance | R _{out} | 80 | 100 | 120 | Ω | |
| Differential data output swing | V _{out,pp} | 300 | | 850 | mV | 1 |
| Output rise time and fall time | T _r , T _f | 24 | | | ps | 2 |
| LOS asserted | V _{LOS_A} | V _{cc} -0.8 | | V _{cc} | V | 3 |
| LOS de-asserted | V _{LOS_D} | 0 | | 0.8 | V | 3 |
| Power Supply Noise Tolerance | V _{CCT} /V _{CCR} | Per SFF-8431 Rev 4.1 | | | mVpp | 4 |
| Power Consumption (-5/85 °C) | | | | | | |
| Tx and Rx CDRs ON | P _{diss-N} | | | 1.8 | W | 5 |
| Tx and Rx CDRs OFF and Ethernet spec. | | | | 1.5 | W | 5 |

Notes:

1. Internally AC coupled. Data pins connect directly to the CDR.
2. 20 – 80%. Measured with Module Compliance Test Board and OMA test pattern. Use of four 1's and four 0's sequence in the PRBS 9 is an acceptable alternative. SFF-8431 Rev 4.1.
3. LOS is an open collector output. Should be pulled up with 4.7kΩ – 10kΩ on the host board. Normal operation is logic 0; loss of signal is logic 1.
4. See Section 2.8.3 of SFF-8431 Rev 4.1.
5. Measured at 85°C, 3.3V and beginning of life.

IV. Optical Characteristics (T_{OP} = -5 to 85 °C, V_{CC} = 3.14 to 3.46 Volts)

| Parameter | Symbol | Min | Typ | Max | Unit | Ref. |
|--|----------------------------------|--------------------|-----|------|-------|------|
| Transmitter (Tx) | | | | | | |
| Output Power | P _{AVE} | -1 | | +2 | dBm | |
| Optical Wavelength | λ | 1530 | | 1565 | nm | |
| Side-Mode Suppression Ratio | SMSR | 30 | | | dB | |
| Optical Extinction Ratio | ER | 8.2 | | | dB | |
| Average Launch power when Tx is OFF | P _{OFF} | | | -30 | dBm | |
| Jitter Generation 20kHz-80MHz, peak-peak | T _{X_{ipk2pk1}} | | | 0.3 | UI | 1 |
| Jitter Generation 4MHz-80MHz, peak-peak | T _{X_{ipk2pj2}} | | | 0.1 | UI | 1 |
| Relative Intensity Noise | RIN | | | -128 | dB/Hz | |
| Receiver (Rx) | | | | | | |
| Optical Center Wavelength | λ_C | 1260 | | 1600 | nm | |
| Receiver Reflectance | R _{Rx} | | | -27 | dB | |
| Sensitivity | 8.5, 9.95-10.7 Gb/s | R _{SENS1} | | -16 | dBm | 2,3 |
| | 11.1-11.3 Gb/s | R _{SENS2} | | -15 | dBm | 2,3 |
| Overload | R _{OVFL} | -1 | | | dBm | 2,3 |
| Path Penalty (800ps/nm) | PP | | | 2 | dB | |
| LOS De-Assert | LOS _D | | | -21 | dBm | |
| LOS Assert | LOS _A | -29 | | | dBm | |
| LOS Hysteresis | LOS _H | 0.5 | | | dB | |

Notes:

- SONET/SDH jitter performance is guaranteed with the internal CDRs enabled and locked
- PRBS 2³¹ - 1 at BER < 10⁻¹²
- Measured with worst ER=8.2 dB

V. General Specifications

| Parameter | Symbol | Min | Typ | Max | Units | Ref. |
|----------------------------|------------------|-----|-----|---------|-------|------|
| Bit Rate | BR | 8.5 | | 11.3168 | Gb/s | 1 |
| Max. Supported Link Length | L _{MAX} | | | 40 | km | 2 |

Notes:

- Tested with a 2³¹ - 1 PRBS pattern at the BER defined in Table IV.
- Over G.652 single mode fiber.

Timing Parameters

| Parameter | Symbol | Min | Typ | Max | Units | Ref. |
|--------------------|-----------------------|-----|-----|-----|-------|------|
| Time to initialize | t _{start_up} | | | 10 | s | |

VI. Environmental Specifications

Finisar FTLX1672M3BNL transceivers have the following temperature specifications:

| Parameter | Symbol | Min | Typ | Max | Units | Ref. |
|----------------------------|------------------|-----|-----|-----|-------|------|
| Case Operating Temperature | T _{op} | -5 | | 85 | °C | |
| Storage Temperature | T _{sto} | -40 | | 85 | °C | |

VII. Regulatory Compliance

Finisar transceivers are Class 1 Laser Products and comply with US FDA regulations. These products are certified by TÜV and CSA to meet the Class 1 eye safety requirements of EN (IEC) 60825 and the electrical safety requirements of EN (IEC) 60950. Copies of certificates are available at Finisar Corporation upon request.

VIII. Digital Diagnostic Functions

Finisar FTLX1672M3BNL SFP+ transceivers support the 2-wire serial communication protocol as defined in the SFP MSA¹. It is very closely related to the E²PROM defined in the GBIC standard, with the same electrical specifications.

The standard SFP serial ID provides access to identification information that describes the transceiver's capabilities, standard interfaces, manufacturer, and other information.

Additionally, Finisar SFP+ transceivers provide an enhanced digital diagnostic monitoring interface, which allows real-time access to device operating parameters such as transceiver temperature, laser bias current, transmitted optical power, received optical power and transceiver supply voltage. It also defines a sophisticated system of alarm and warning flags, which alerts end-users when particular operating parameters are outside of a factory set normal range.

The SFP MSA defines a 256-byte memory map in E²PROM that is accessible over a 2-wire serial interface at the 8 bit address 1010000X (A0h). The digital diagnostic monitoring interface makes use of the 8 bit address 1010001X (A2h), so the originally defined serial ID memory map remains unchanged. The interface is identical to, and is thus fully backward compatible with both the GBIC Specification and the SFP Multi Source Agreement. The complete interface is described in Finisar Application Note AN-2030: "Digital Diagnostics Monitoring Interface for SFP Optical Transceivers".

The operating and diagnostics information is monitored and reported by a Digital Diagnostics Transceiver Controller (DDTC) inside the transceiver, which is accessed through a 2-wire serial interface. When the serial protocol is activated, the serial clock signal (SCL, Mod Def 1) is generated by the host. The positive edge clocks data into the SFP transceiver into those segments of the E²PROM that are not write-protected. The negative edge clocks data from the SFP transceiver. The serial data signal (SDA, Mod Def 2) is bi-directional for serial data transfer. The host uses SDA in conjunction with SCL to mark the start and end of serial protocol activation. The memories are organized as a series of 8-bit data words that can be addressed individually or sequentially.

For more information, please see the SFP MSA documentation³ and Finisar Application Note AN-2030⁷.

Please note that evaluation board FDB-1027 is available with Finisar ModDEMO software that allows simple to use communication over the 2-wire serial interface.

IX. Digital Diagnostic Specifications

FTLX1672M3BNL transceivers can be used in host systems that require either internally or externally calibrated digital diagnostics.

| Parameter | Symbol | Units | Min | Max | Accuracy | Ref. |
|--------------------------------------|------------------------|-------|-----|-----|----------|------|
| Accuracy | | | | | | |
| Transceiver temperature | ΔDD_{Temp-E} | °C | -10 | +90 | ±5°C | 1 |
| Transceiver supply voltage | $\Delta DD_{Voltage}$ | V | 2.8 | 4.0 | ±3% | |
| Transmitter bias current | ΔDD_{Bias} | mA | 0 | 127 | ±10% | 2 |
| Transmitter output power | $\Delta DD_{Tx-Power}$ | dBm | -2 | +3 | ±2dB | |
| Receiver average optical input power | $\Delta DD_{Rx-Power}$ | dBm | -20 | +1 | ±2dB | |

Notes:

- Internally measured
- The accuracy of the Tx bias current is 10% of the actual current from the laser driver to the laser

X. Internal CDR's Locking Modes

The FTLX1672M3BNL is equipped with internal CDR units on both the receiver and the transmitter sides. The host can set the CDR's to lock at 8.5Gb/s, 10G (9.95-11.3Gb/s), or in by-pass mode, by setting the rate select pins or the soft bits (logic OR). The different locking modes are shown in the following logic table:

| R/S 0 Logic OR of: pin 7 & bit 110.3 | R/S 1 Logic OR of: pin 9 & bit 118.3 | CDRs Locking Mode |
|--|--|---|
| Low or 0 | Low or 0 | Both CDRs lock at 8.5Gb/s |
| Low or 0 | High or 1 | Tx CDR is in bypass mode. Rx CDR locks at 10G (9.95-11.3Gb/s) |
| High or 1 | Low or 0 | Tx & Rx CDRs in bypass mode |
| High or 1 | High or 1 | Both CDRs lock at 10G (9.95-11.3Gb/s) The bits 110.3 and 118.3 are set to 1 by default at power-up |

The RS0 and RS1 pins are internally pulled-down to ground as per [1]. The soft bits 110.3 and 118.3 are both set to “1” at the transceiver power-up, to select the 10G locking mode by default. The host can change this configuration via the 2-wire communication as described in the SFP MSA [1]. Alternative configurations can be factory set upon request. Please refer to Finisar for additional details.

XI. SFF-8431 Power-up Sequence

If either CDR is enabled, the typical power consumption of the FTLX1672M3BNL may exceed the limit of 1.5W specified for the Power Level II transceivers in [1], for which a power-up sequence is recommended. However, the FTLX1672M3BNL is factory set to power-up directly to its operating conditions. Upon request, it can be factory set to follow the power-up sequence specified for transceivers exceeding 1W, as per [1]. In power level I, the FTLX1672M3BNL does not carry traffic, but the 2-wire serial communication is active.

Please refer to [1] and Finisar Application Note AN-2076 for additional details.

XII. Mechanical Specifications

Finisar FTLX1672M3BNL SFP+ transceivers are compatible with the SFF-8432 specification for improved pluggable form factor, and shown here for reference purposes only. Bail color is red.

| ITEM | DIM (mm) | TOL (mm) |
|------|----------|----------|
| A | 9.00 | ± 0.3 |
| B | 9.60 | ± 0.5 |
| C | 11.90 | ± 0.5 |
| D | 13.85 | ± 0.15 |
| E | 13.65 | ± 0.15 |
| F | 2.80 | ± 0.2 |
| G | 1.00 | ± 0.2 |
| H | 4.00 | REF |
| J | 2.00 | ± 0.2 |
| K | 56.50 | REF |
| L | 1.60 | ± 0.5 |
| M | 2.25 | ± 0.1 |
| N | 1.80 | ± 0.1 |
| P | 37.10 | ± 0.3 |
| Q | 9.15 | ± 0.15 |
| R | 1.00 | ± 0.1 |
| S | 8.55 | ± 0.15 |
| T | 47.50 | ± 0.2 |
| V | 2.55 | ± 0.1 |
| W | 43.00 | ± 0.2 |
| X | 14.70 | ± 0.5 |
| Z | 0.55 | ± 0.15 |

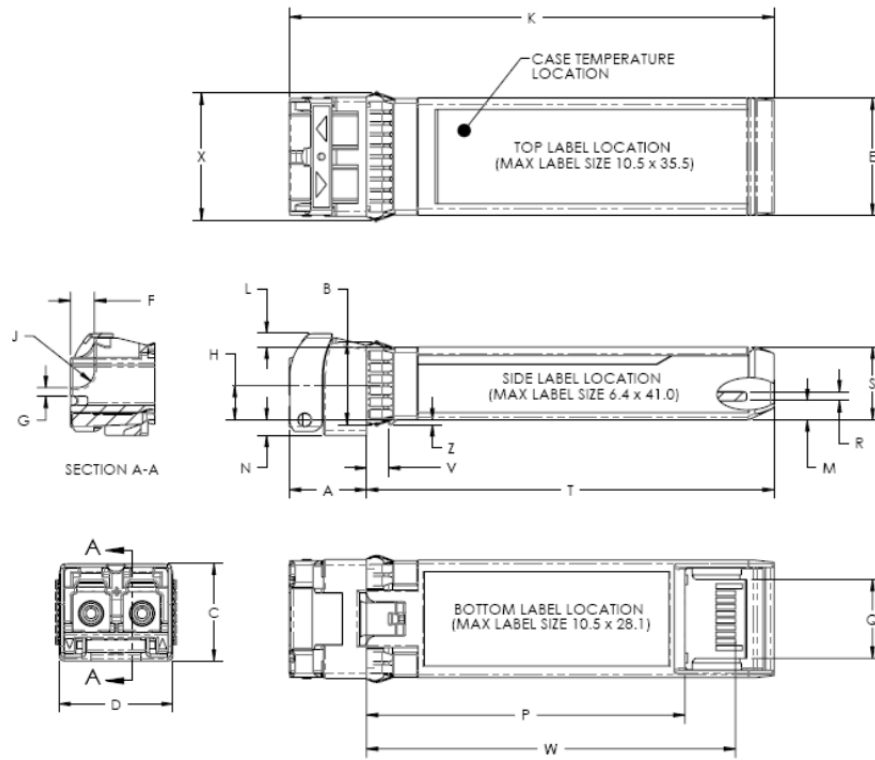

Figure 2. Mechanical Dimensions

Note: the option of the label on the top side of the transceiver is not recommended

XIV. Host-Module Interface Diagram

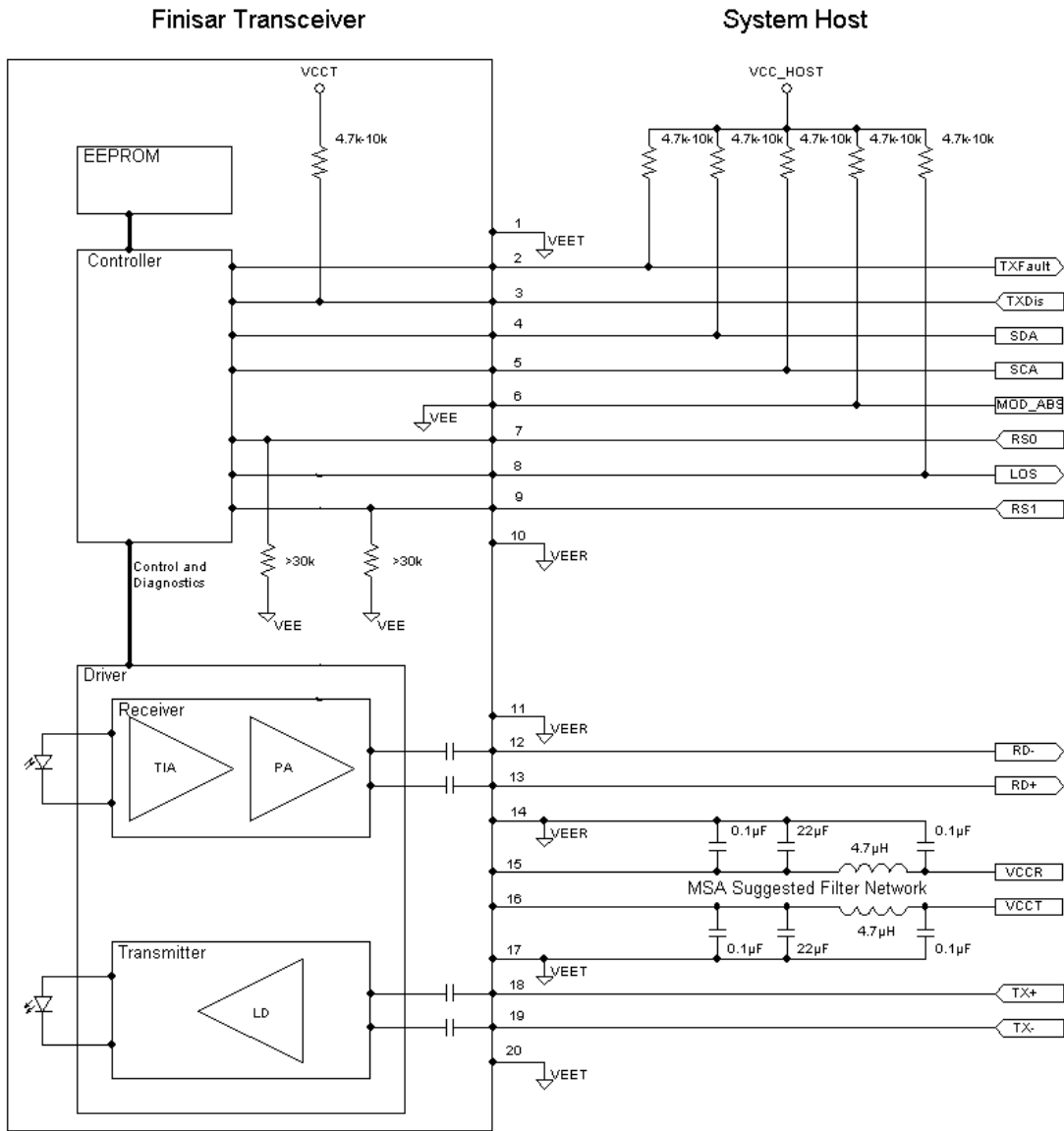

Figure 5

XV. References

1. “Specifications for Enhanced 8.5 and 10 Gigabit Small Form Factor Pluggable Module ‘SFP+ ‘”, SFF Document Number SFF-8431, Revision 4.1, including SFF-8431 Rev 4.1 Addendum. September 15, 2013.
2. “Improved Pluggable Form factor”, SFF Document Number SFF-8432, Revision 4.2, April 18, 2007.
3. “Digital Diagnostics Monitoring Interface for Optical Transceivers”. SFF Document Number SFF-8472, Revision 10.1, March 1, 2007.
4. Directive 2011/65/EU of the European Council Parliament and of the Council, “on the restriction of the use of certain hazardous substances in electrical and electronic equipment”
5. “Application Note AN-2038: Finisar Implementation of RoHS Compliant Transceivers”
6. Small Form-factor Pluggable (SFP) Transceiver Multi-Source Agreement (MSA)
7. “Application Note AN-2030: Digital Diagnostic Monitoring Interface for SFP Optical Transceivers”

XVI. For More Information

Finisar Corporation
1389 Moffett Park Drive
Sunnyvale, CA 94089-1133
Tel. 1-408-548-1000
Fax 1-408-541-6138
sales@finisar.com
www.finisar.com