



Chipsmall Limited consists of a professional team with an average of over 10 year of expertise in the distribution of electronic components. Based in Hongkong, we have already established firm and mutual-benefit business relationships with customers from,Europe,America and south Asia,supplying obsolete and hard-to-find components to meet their specific needs.

With the principle of “Quality Parts,Customers Priority,Honest Operation,and Considerate Service”,our business mainly focus on the distribution of electronic components. Line cards we deal with include Microchip,ALPS,ROHM,Xilinx,Pulse,ON,Everlight and Freescale. Main products comprise IC,Modules,Potentiometer,IC Socket,Relay,Connector.Our parts cover such applications as commercial,industrial, and automotives areas.

We are looking forward to setting up business relationship with you and hope to provide you with the best service and solution. Let us make a better world for our industry!



## Contact us

Tel: +86-755-8981 8866 Fax: +86-755-8427 6832

Email & Skype: info@chipsmall.com Web: www.chipsmall.com

Address: A1208, Overseas Decoration Building, #122 Zhenhua RD., Futian, Shenzhen, China



## Product Specifications

### 10Gb/s, 1310nm 40km, Single Mode, Multi-Rate SFP+ Transceiver FTLX1772M3BCL

#### PRODUCT FEATURES

- Hot-pluggable SFP+ footprint
- 17dB optical link budget for up to 40km<sup>(1)</sup> over G.652 single mode fiber
- Supports 6.144, 8.5G and from 9.83 to 11.3 Gb/s bit rates
- Un-cooled 1310nm DFB laser
- Receiver limiting electrical interface
- Power dissipation < 1.5W
- -5°C to 75°C temperature range
- RoHS-6 compliant (lead-free)
- Single 3.3V power supply
- Duplex LC connector
- Built-in digital diagnostic functions



#### APPLICATIONS

- 6.144G/9.83G CPRI
- 8.5Gb/s Fibre Channel
- 10G NRZ SONET, SDH
- 10G Ethernet and Fibre Channel
- G.709 OTN FEC bit rates

Finisar's FTLX1772M3BCL 10Gb/s Pluggable SFP+ transceivers are compliant with SFF-8431<sup>1</sup> and SFF-8432<sup>2</sup>, and support 10G SONET, SDH, OTN, IEEE 802.3ae, 8x/10x Fibre Channel and 6.144G/9.83 CPRI. The transceivers have higher optical transmit power and better receiver sensitivity than 1310nm 10GBASE-LR and OC-192 SR-1 transceivers, and they support an optical link budget of 17dB, to compensate for the higher fiber attenuation loss at 1310nm over 40km<sup>(1)</sup> of G.652 single mode fiber.

Digital diagnostics functions are available via a 2-wire serial interface, as specified in SFF-8472<sup>6</sup>. The FTLX1772M3BCL transceivers utilize internal transmitter and receiver re-timer IC's for SONET/SDH jitter compliance and to enhance host cards' signal integrity. The optical transceiver is compliant per the RoHS Directive 2011/65/EU. See Finisar Application Note AN-2038 for more details<sup>7,8</sup>.

#### PRODUCT SELECTION

**FTLX1772M3BCL**

Note (1): Links longer than 30 km for the same optical link budget are considered engineered links (see Sec. IV)

## I. Pin Descriptions

Pin	Symbol	Name/Description	Ref.
1	V <sub>EET</sub>	Transmitter Ground	1
2	T <sub>FAULT</sub>	Transmitter Fault	2
3	T <sub>DIS</sub>	Transmitter Disable. Laser output disabled on high or open.	3
4	SDA	2-wire Serial Interface Data Line	2
5	SCL	2-wire Serial Interface Clock Line	2
6	MOD_ABS	Module Absent. Grounded within the module	2
7	RS0	Rate Select 0.	4
8	RX_LOS	Loss of Signal indication. Logic 0 indicates normal operation.	5
9	RS1	Rate Select 1.	4
10	V <sub>EER</sub>	Receiver Ground	1
11	V <sub>EER</sub>	Receiver Ground	1
12	RD-	Receiver Inverted DATA out. AC Coupled.	
13	RD+	Receiver Non-inverted DATA out. AC Coupled.	
14	V <sub>EER</sub>	Receiver Ground	1
15	V <sub>CCR</sub>	Receiver Power Supply	
16	V <sub>CCT</sub>	Transmitter Power Supply	
17	V <sub>EET</sub>	Transmitter Ground	1
18	TD+	Transmitter Non-Inverted DATA in. AC Coupled.	
19	TD-	Transmitter Inverted DATA in. AC Coupled.	
20	V <sub>EET</sub>	Transmitter Ground	1

### Notes:

- Circuit ground is internally isolated from chassis ground.
- T<sub>FAULT</sub> is an open collector/drain output, which should be pulled up with a 4.7k – 10k Ohms resistor on the host board if intended for use. Pull up voltage should be between 2.0V to V<sub>cc</sub> + 0.3V. A high output indicates a transmitter fault caused by either the TX bias current or the TX output power exceeding the preset alarm thresholds. A low output indicates normal operation. In the low state, the output is pulled to <0.8V.
- Laser output disabled on T<sub>DIS</sub> >2.0V or open, enabled on T<sub>DIS</sub> <0.8V.
- Internally pulled down per SFF-8431 Rev 2.0. See Sec. X for the logic table to use for the internal CDRs locking modes.
- LOS is open collector output. Should be pulled up with 4.7k – 10kΩ on host board to a voltage between 2.0V and 3.6V. Logic 0 indicates normal operation; logic 1 indicates loss of signal.

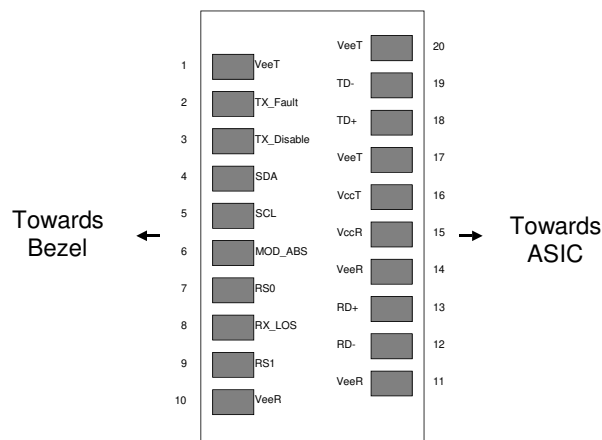

Figure 1. Diagram of Host Board Connector Block Pin Numbers and Names.



## II. Absolute Maximum Ratings

Exceeding the limits below may damage the transceiver module permanently.

Parameter	Symbol	Min	Typ	Max	Unit	Ref.
Maximum Supply Voltage	V <sub>cc</sub>	-0.5		4.0	V	
Storage Temperature	T <sub>s</sub>	-40		85	°C	
Relative Humidity	RH	0		85	%	1
Receiver Damage Threshold	R <sub>Damage</sub>			+5	dBm	

### Notes:

1. Non-condensing.

## III. Electrical Characteristics (T<sub>OP</sub> = -5 to 75 °C)

Parameter	Symbol	Min	Typ	Max	Unit	Ref.
Supply Voltage	V <sub>cc</sub>	3.14	3.30	3.46	V	
Supply Current	I <sub>cc</sub>		300	430	mA	
Power Dissipation	P <sub>diss</sub>			1.5	W	
<b>Transmitter</b>						
Input differential impedance	R <sub>in</sub>		100		Ω	1
Differential data input swing	V <sub>in,pp</sub>	200		1800	mV	
Transmit Disable Voltage	V <sub>D</sub>	V <sub>cc</sub> -0.8		V <sub>cc</sub>	V	
Transmit Enable Voltage	V <sub>EN</sub>	V <sub>ee</sub>		V <sub>ee</sub> + 0.8	V	
<b>Receiver</b>						
Differential data output swing	V <sub>out,pp</sub>	300		850	mV	2
Output rise time and fall time	T <sub>r</sub> , T <sub>f</sub>	28			ps	3
LOS asserted	V <sub>LOS A</sub>	V <sub>cc</sub> -0.8		V <sub>cc</sub>	V	4
LOS de-asserted	V <sub>LOS D</sub>	V <sub>ee</sub>		V <sub>ee</sub> +0.8	V	4
Power Supply Noise Tolerance	V <sub>cc</sub> T/V <sub>cc</sub> R	Per SFF-8431 Rev 3.0			mVpp	5

### Notes:

1. Connected directly to TX data input pins. AC coupling from pins into laser driver IC.
2. Into 100Ω differential termination.
3. 20 – 80%. Measured with Module Compliance Test Board and OMA test pattern. Use of four 1's and four 0's sequence in the PRBS 9 is an acceptable alternative. SFF-8431 Rev 3.0.
4. LOS is an open collector output. Should be pulled up with 4.7kΩ – 10kΩ on the host board. Normal operation is logic 0; loss of signal is logic 1.
5. See Section 2.8.3 of SFF-8431 Rev 3.0.

#### IV. Optical Characteristics ( $T_{OP} = -5$ to $75$ °C, $V_{CC} = 3.14$ to $3.46$ Volts)

Parameter	Symbol	Min	Typ	Max	Unit	Note
<b>Transmitter (Tx)</b>						
Average Launch Power	$P_{AVE}$	-3		+4	dBm	
Optical Wavelength	$\lambda$	1290		1330	nm	
Side-Mode Suppression Ratio	SMSR	30			dB	
Optical Extinction Ratio	ER	6			dB	
Path Penalty	$TDP_S$			1	dB	
Transmitter and Dispersion Penalty	$TDP_E$			3.2	dB	
Average Launch power when Tx is OFF	$P_{OFF}$			-30	dBm	
Tx Jitter 20kHz-80MHz	$TX_{j1}$			0.3	UI	1,2
Tx Jitter 4MHz – 80MHz	$TX_{j2}$			0.1	UI	1,2
Relative Intensity Noise	RIN			-128	dB/Hz	
<b>Receiver (Rx)</b>						
Sensitivity (Average Power)	8.5-10.7Gb/s	$R_{SENS1}$			-20	dBm 3,4
	11.1-11.3Gb/s	$R_{SENS2}$			-19	dBm 3,5
Sensitivity (OMA)	9.95-10.3Gb/s	$R_{SENS3}$			-19.2	dBm 3,4
Stressed Sensitivity (OMA)	9.95-10.3Gb/s	$R_{SENS4}$			-11.3	dBm 6
Overload (Average Power)	$P_{AVE}$	-7			dBm	
Optical Center Wavelength	$\lambda_C$	1260		1600	Nm	
Receiver Reflectance	$R_{TX}$			-14	dB	
LOS De-Assert	$LOS_D$			-22	dBm	
LOS Assert	$LOS_A$	-42			dBm	
LOS Hysteresis	$LOS_H$	0.5			dB	

##### Notes:

- For SONET/SDH applications the jitter specifications are defined as per [9].
- If the CDRs are in bypass mode, the Tx jitter is compliant to the specification defined in [4].
- Measured with worst ER=6 dB;  $2^{31} - 1$  PRBS.
- Measured for BER <  $10^{-12}$ .
- Measured for BER >  $10^{-5}$ .
- As per [4].

#### IV. General Specifications

Bit rates: CDR's lock at 8.5Gb/s, and from 9.83Gb/s to 11.3168Gb/s bit rates. With CDR's in bypass mode 6.144Gb/s CPRI is also supported.

Parameter	Symbol	Min	Typ	Max	Units	Note
Supported Link Length	$L_{MAX}$	10		30	km	1,2,3
		10		40	km	1,2,3,4

##### Notes:

- Tested with a  $2^{31} - 1$  PRBS pattern and BER of  $1E-12$ , over G.652 single mode fiber.
- Assuming that the optical link loss due to fiber attenuation is 0.38dB/km.
- The actual min. link length may differ as it is affected by the receiver overload limit.
- Assuming FTLX1772M3BCL transceivers on both side of the link. If a PIN receiver is on the other side of the link, the optical link budget may not be enough to support 40km of fiber attenuation loss.

## VI. Environmental Specifications

The operating temperatures of Finisar FTLX1772M3BCL are shown in the following table

Parameter	Symbol	Min	Typ	Max	Units	Ref.
Case Operating Temperature	T <sub>op</sub>	-5		75	°C	
Storage Temperature	T <sub>sto</sub>	-40		85	°C	

## VII. Regulatory Compliance

Finisar transceivers are Class 1 Laser Products and comply with US FDA regulations. These products are certified by TÜV and CSA to meet the Class 1 eye safety requirements of EN (IEC) 60825 and the electrical safety requirements of EN (IEC) 60950. Copies of certificates are available at Finisar Corporation upon request.

## VIII. Digital Diagnostic Functions

Finisar FTLX1772M3BCL SFP+ transceivers support the 2-wire serial communication protocol as defined in the SFP MSA [1]. It is very closely related to the E<sup>2</sup>PROM defined in the GBIC standard, with the same electrical specifications.

The standard SFP serial ID provides access to identification information that describes the transceiver's capabilities, standard interfaces, manufacturer, and other information.

Additionally, Finisar SFP+ transceivers provide an enhanced digital diagnostic monitoring interface, which allows real-time access to device operating parameters such as transceiver temperature, laser bias current, transmitted optical power, received optical power and transceiver supply voltage. It also defines a sophisticated system of alarm and warning flags, which alerts end-users when particular operating parameters are outside of a factory set normal range.

The SFP MSA defines a 256-byte memory map in E<sup>2</sup>PROM that is accessible over a 2-wire serial interface at the 8 bit address 1010000X (A0h). The digital diagnostic monitoring interface makes use of the 8 bit address 1010001X (A2h), so the originally defined serial ID memory map remains unchanged. The interface is identical to, and is thus fully backward compatible with both the GBIC Specification and the SFP Multi Source Agreement. The complete interface is described in Finisar Application Note AN-2030: "Digital Diagnostics Monitoring Interface for SFP Optical Transceivers".

The operating and diagnostics information is monitored and reported by a Digital Diagnostics Transceiver Controller (DDTC) inside the transceiver, which is accessed through a 2-wire serial interface. When the serial protocol is activated, the serial clock signal (SCL, Mod Def 1) is generated by the host. The positive edge clocks data into the SFP transceiver into those segments of the E<sup>2</sup>PROM that are not write-protected. The negative edge clocks data from the SFP transceiver. The serial data signal (SDA, Mod Def 2) is bi-directional for serial data transfer. The host uses SDA in conjunction with SCL to mark the start and end of serial protocol activation. The memories are organized as a series of 8-bit data words that can be addressed individually or sequentially.

For more information, please see the SFP MSA documentation [1], [6] and Finisar Application Note AN-2030. Please note that evaluation board FDB-1027 is available with Finisar ModDEMO software that allows simple to use communication over the 2-wire serial interface.

## IX. Digital Diagnostic Specifications

The Digital Diagnostic Monitors of the FTLX1772M3BCL transceivers are factory set to external calibration.

Parameter	Symbol	Units	Min	Max	Accuracy	Ref.
<b>Accuracy</b>						
Transceiver temperature	$\Delta DD_{Temp}$	°C	-10	80	±5°C	1
Transceiver supply voltage	$\Delta DD_{Voltage}$	V	2.8	4.0	±3%	
Transmitter bias current	$\Delta DD_{Bias}$	mA	0	20	±10%	2
Transmitter output power	$\Delta DD_{Tx-Power}$	dBm	-10	+2	±2dB	
Receiver average optical input power	$\Delta DD_{Rx-Power}$	dBm	-22	+2	±2dB	

Notes: 1. Internally measured

2. Accuracy of measured Tx bias current is 10% of the actual bias current from the laser driver to the laser.

## X. Internal CDR's Locking Modes

The FTLX1772M3BCL is equipped with internal CDR units on both the receiver and the transmitter sides. The host can set the CDR's to lock at 8.5Gb/s, 10G (9.83-11.3Gb/s), or in by-pass mode, by setting the rate select pins or the soft bits (logic OR). The different locking modes are shown in the following logic table:

R/S 0 Logic OR of: pin 7 & bit 110.3	R/S 1 Logic OR of: pin 9 & bit 118.3	CDR's Locking Mode
Low or 0	Low or 0	Both CDR's lock at 8.5Gb/s
Low or 0	High or 1	Tx CDR is in bypass mode. Rx CDR locks at 10G (9.83-11.3Gb/s)
High or 1	Low or 0	Tx & Rx CDR's in bypass mode
High or 1	High or 1	Both CDR's lock at 10G (9.83-11.3Gb/s) The bits 110.3 and 118.3 are set to 1 by default at power-up

The RS0 and RS1 pins are internally pulled-down to ground as per [1]. The soft bits 110.3 and 118.3 are both set to "1" at the transceiver power-up, to select the 10G locking mode by default. The host can change this configuration via the 2-wire communication as described in the SFP MSA [1]. Alternative configurations can be factory set upon request. Please refer to Finisar for additional details.

## XI. SFF-8431 Power-up Sequence

The typical power consumption of the FTLX1772M3BCL will not exceed the limit of 1.5W specified in [1] for the Power Level II device. Moreover, the FTLX1772M3BCL is factory set to power-up directly to its operating conditions, but upon request, it can be factory set to follow the power-up sequence specified in the SFF-8431 for transceivers exceeding 1W. For additional details please, refer to [1] and Finisar's Application Note AN-2076.



## XII. Mechanical Specifications

Finisar FTLX1772M3BCL SFP+ transceivers are compatible with the SFF-8432 specification for improved pluggable form factor and shown here for reference purposes only. Bail color is blue.

ITEM	DIM (mm)	TOL (mm)
A	9.00	± 0.3
B	9.60	± 0.5
C	11.90	± 0.5
D	13.85	± 0.15
E	13.65	± 0.15
F	2.80	± 0.2
G	1.00	± 0.2
H	4.00	REF
J	2.00	± 0.2
K	56.50	REF
L	1.60	± 0.5
M	2.25	± 0.1
N	1.80	± 0.1
P	37.10	± 0.3
Q	9.15	± 0.15
R	1.00	± 0.1
S	8.55	± 0.15
T	47.50	± 0.2
V	2.55	± 0.1
W	43.00	± 0.2
X	14.70	± 0.5
Z	0.55	± 0.15

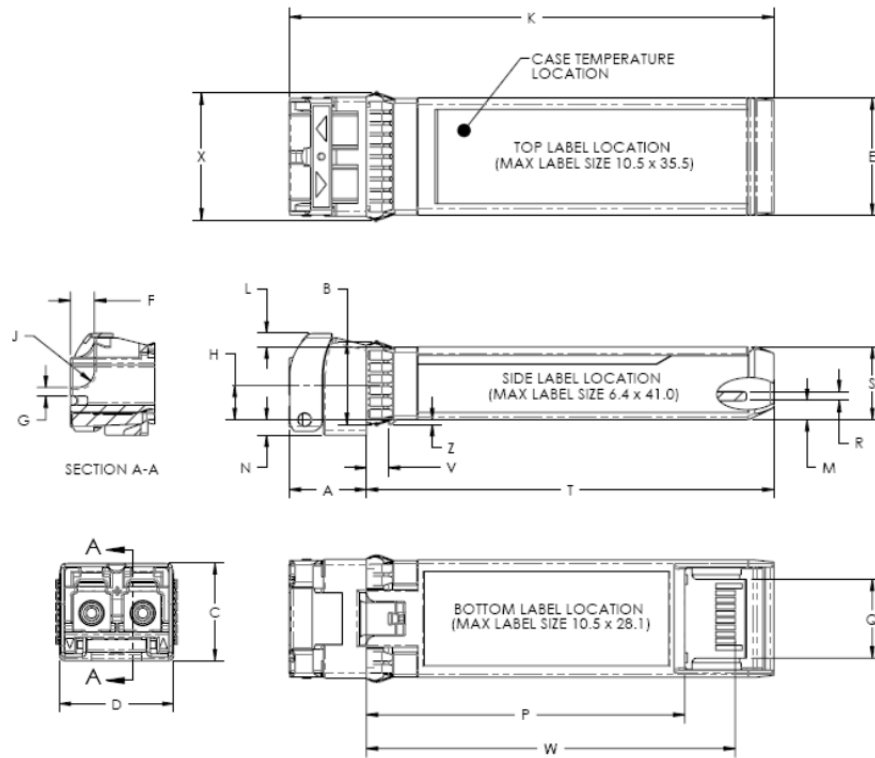

Figure 2. Mechanical Dimensions

### XIII. PCB Layout and Bezel Recommendations

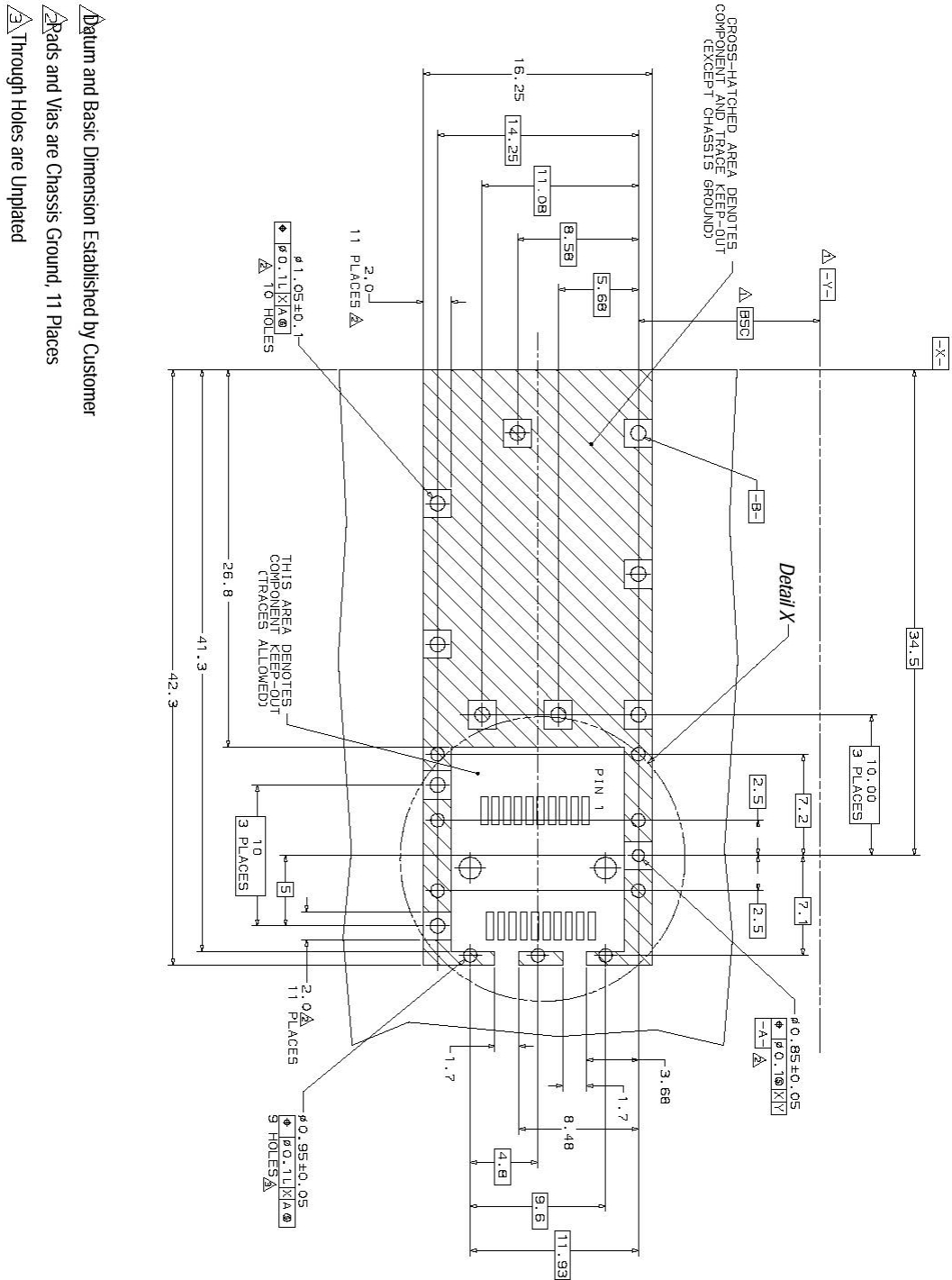
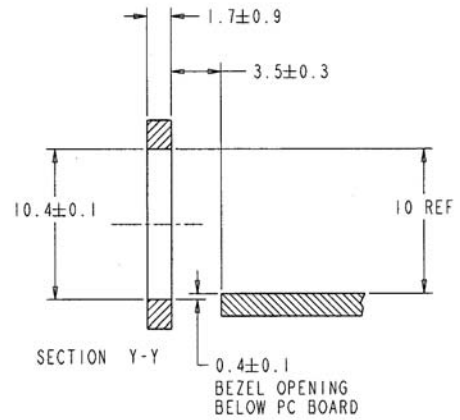
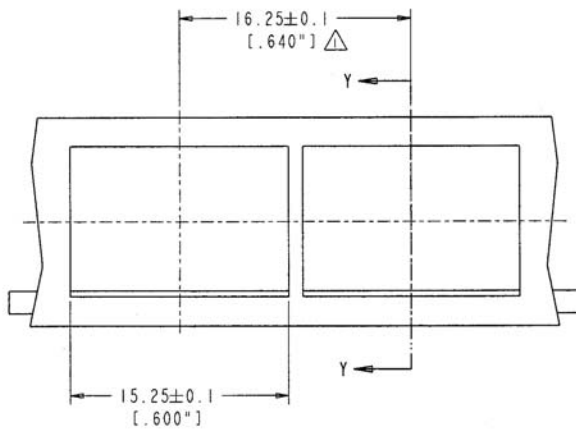
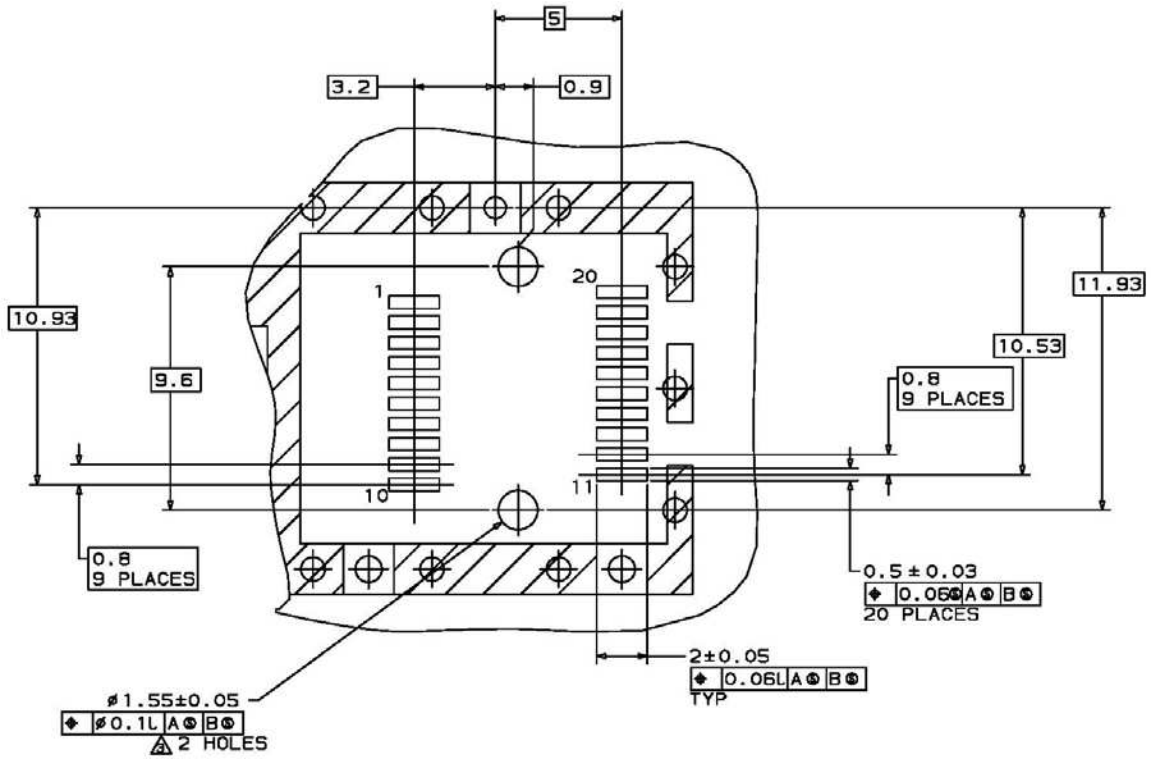

Figure 3. PCB Layout and Bezel Recommendations



NOTES:

1. △ MINIMUM PITCH ILLUSTRATED, ENGLISH DIMENSIONS ARE FOR REFERENCE ONLY

2. NOT RECOMMENDED FOR PCI EXPANSION CARD APPLICATIONS

#### XIV. References

1. “Specifications for Enhanced 8.5 and 10 Gigabit Small Form Factor Pluggable Module ‘SFP+ ‘”, SFF Document Number SFF-8431, Revision 4.1, including SFF-8431 Rev 4.1 Addendum. September 15, 2013.
2. “Improved Pluggable Form factor”, SFF Document Number SFF-8432, Revision 4.2, April 18, 2007.
3. ITU-T G.693, VSR2000-2R1 Optical interface parameters specified for SONET/SDH applications with 2km target distance
4. IEEE 802.3ae, Clause 52, PMD Type 10GBASE-ER. IEEE Standards Department.
5. American National Standard for Information Technology - Fibre Channel - 10 Gigabit Fibre Channel, Rev 3.5, April 9, 2003.
6. “Digital Diagnostics Monitoring Interface for Optical Transceivers”. SFF Document Number SFF-8472, Revision 10.1, March 1, 2007.
7. Directive 2011/65/EU of the European Council Parliament and of the Council, “on the restriction of the use of certain hazardous substances in electrical and electronic equipment”
8. “Application Note AN-2038: Finisar Implementation of RoHS Compliant Transceivers”
9. ITU-T G.8251, The control of jitter and wander within the optical transport network (OTN)
10. Fibre Channel, Physical Interface-5, (FC-PI-5), REV 6.00, September 21, 2010

#### XV. Revision History

Revision	Date	Description
B1	4/18/2014	Production Release
C1	9/7/2015	Updated logo and RoHS statement

#### XVI. For More Information

Finisar Corporation  
 1389 Moffett Park Drive  
 Sunnyvale, CA 94089-1133  
 Tel. 1-408-548-1000  
 Fax 1-408-541-6138  
[sales@finisar.com](mailto:sales@finisar.com)  
[www.finisar.com](http://www.finisar.com)