



Chipsmall Limited consists of a professional team with an average of over 10 year of expertise in the distribution of electronic components. Based in Hongkong, we have already established firm and mutual-benefit business relationships with customers from,Europe,America and south Asia,supplying obsolete and hard-to-find components to meet their specific needs.

With the principle of “Quality Parts,Customers Priority,Honest Operation,and Considerate Service”,our business mainly focus on the distribution of electronic components. Line cards we deal with include Microchip,ALPS,ROHM,Xilinx,Pulse,ON,Everlight and Freescale. Main products comprise IC,Modules,Potentiometer,IC Socket,Relay,Connector.Our parts cover such applications as commercial,industrial, and automotives areas.

We are looking forward to setting up business relationship with you and hope to provide you with the best service and solution. Let us make a better world for our industry!



Contact us

Tel: +86-755-8981 8866 Fax: +86-755-8427 6832

Email & Skype: info@chipsmall.com Web: www.chipsmall.com

Address: A1208, Overseas Decoration Building, #122 Zhenhua RD., Futian, Shenzhen, China



Product Specification

1G/10G 850nm Multimode Datacom SFP+ Transceiver

FTLX8574D3BCV

PRODUCT FEATURES

- Hot-pluggable SFP+ footprint
- Supports rate selectable 1.25 Gb/s or 9.95 to 10.3 Gb/s bit rates
- Power dissipation < 1W
- RoHS-6 compliant (lead-free)
- Commercial temperature range -5°C to 70°C
- Single 3.3V power supply
- Maximum link length of 400m on OM4 MMF
- Uncooled 850nm VCSEL laser
- Receiver limiting electrical interface
- Duplex LC connector
- Built-in digital diagnostic functions



APPLICATIONS

- 1000BASE-SX 1G Ethernet
- 10GBASE-SR/SW 10G Ethernet

Finisar's FTLX8574D3BCV 1G/10G Dual-Rate SFP+ transceivers are designed for use in 1-Gigabit and 10-Gigabit Ethernet links over multimode fiber. They are compliant with SFF-8431¹, IEEE 802.3-2012 10GBASE-SR/SW² and 1000BASE-SX³. Digital diagnostics functions are available via a 2-wire serial interface, as specified in SFF-8472⁴. The FTLX8574D3BCV is a "limiting module", i.e., it employs a limiting receiver. Host board designers using an EDC PHY IC should follow the IC manufacturer's recommended settings for interoperability with an SFP+ limiting module. This product is for applications specifically designed for 10G SFP+ ports and 1G/10G SFP+ ports and not native 1G SFP ports. The optical transceiver is compliant per the RoHS Directive 2011/65/EU⁵. See Finisar Application Note AN-2038⁶ for more details.

PRODUCT SELECTION

FTLX8574D3BCV

I. Pin Descriptions

Pin	Symbol	Name/Description	Ref.
1	V _{EET}	Transmitter Ground (Common with Receiver Ground)	1
2	T _{FAULT}	Transmitter Fault.	2
3	T _{DIS}	Transmitter Disable. Laser output disabled on high or open.	3
4	SDA	2-wire Serial Interface Data Line	4
5	SCL	2-wire Serial Interface Clock Line	4
6	MOD_ABS	Module Absent. Grounded within the module	4
7	RS0	RS0 for Rate Select: Open or Low = Module supports 1.25 Gb/s High = Module supports 9.95 Gb/s to 10.3125 Gb/s	5
8	RX_LOS	Loss of Signal indication. Logic 0 indicates normal operation.	6
9	RS1	No connection required	
10	V _{EER}	Receiver Ground (Common with Transmitter Ground)	1
11	V _{EER}	Receiver Ground (Common with Transmitter Ground)	1
12	RD-	Receiver Inverted DATA out. AC Coupled	
13	RD+	Receiver Non-inverted DATA out. AC Coupled	
14	V _{EER}	Receiver Ground (Common with Transmitter Ground)	1
15	V _{CCR}	Receiver Power Supply	
16	V _{CCT}	Transmitter Power Supply	
17	V _{EET}	Transmitter Ground (Common with Receiver Ground)	1
18	TD+	Transmitter Non-Inverted DATA in. AC Coupled.	
19	TD-	Transmitter Inverted DATA in. AC Coupled.	
20	V _{EET}	Transmitter Ground (Common with Receiver Ground)	1

Notes:

- Circuit ground is internally isolated from chassis ground.
- T_{FAULT} is an open collector/drain output, which should be pulled up with a 4.7k – 10k Ohms resistor on the host board if intended for use. Pull up voltage should be between 2.0V to V_{cc} + 0.3V. A high output indicates a transmitter fault caused by either the TX bias current or the TX output power exceeding the preset alarm thresholds. A low output indicates normal operation. In the low state, the output is pulled to <0.8V.
- Laser output disabled on T_{DIS} >2.0V or open, enabled on T_{DIS} <0.8V.
- Should be pulled up with 4.7kΩ – 10kΩ on host board to a voltage between 2.0V and 3.6V. MOD_ABS pulls line low to indicate module is plugged in.
- Transceiver data rate selected through the 2-wire bus in accordance with SFF-8472 Rev. 10.3. Soft RS0 is set at Bit3, Byte 110, Address A2h. Soft RS0 default state on power up is '0' LOW, and the state is reset following a power cycle. Writing '1' HIGH selects max. data rate operation. Transceiver data rate is the logic OR of the input state of the RS0 pin and soft RS0 bit. Thus, if either the RS0 pin OR the soft RS0 bit is HIGH then the selected data rate will be 9.95 and 10.3 Gb/s. Conversely, to select data rate 1.25 Gb/s both the RS0 pin and the soft RS0 bit are set LOW.
- LOS is open collector output. Should be pulled up with 4.7kΩ – 10kΩ on host board to a voltage between 2.0V and 3.6V. Logic 0 indicates normal operation; logic 1 indicates loss of signal.

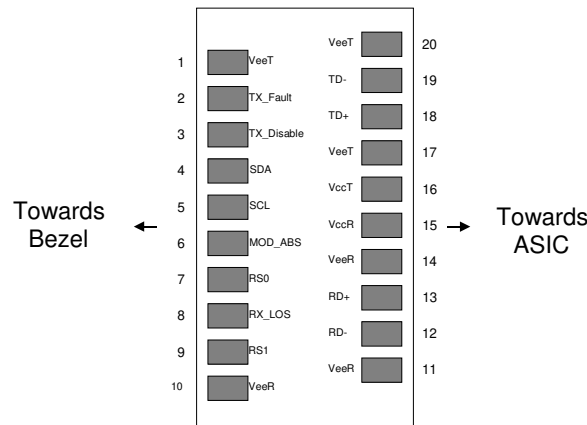

Figure 1. Diagram of Host Board Connector Block Pin Numbers and Names.

II. Absolute Maximum Ratings

Exceeding the limits below may damage the transceiver module permanently.

Parameter	Symbol	Min	Typ	Max	Unit	Ref.
Maximum Supply Voltage	V _{cc}	-0.5		4.0	V	
Storage Temperature	T _s	-40		85	°C	
Case Operating Temperature	T _A	-5		70	°C	
Relative Humidity	RH	0		85	%	1

Notes:

1. Non-condensing.

III. Electrical Characteristics (T_{OP} = -5 to 70 °C, V_{CC} = 3.14 to 3.46 Volts)

Parameter	Symbol	Min	Typ	Max	Unit	Ref.
Supply Voltage	V _{cc}	3.14		3.46	V	
Supply Current	I _{cc}			250	mA	
Transmitter						
Input differential impedance	R _{in}		100		Ω	1
Differential data input swing	V _{in,pp}	180		700	mV	2
Transmit Disable Voltage	V _D	2		V _{cc}	V	
Transmit Enable Voltage	V _{EN}	V _{ee}		V _{ee} + 0.8	V	
Receiver						
Differential data output swing	V _{out,pp}	300		850	mV	3
Data output rise time, fall time	t _r	28			ps	4
LOS Fault	V _{LOS fault}	2		V _{cc,HOST}	V	5
LOS Normal	V _{LOS norm}	V _{ee}		V _{ee} +0.8	V	5
Power Supply Noise Tolerance	V _{ccT/V_{ccR}}	Per SFF-8431 Rev 4.1			mVpp	6

Notes:

1. Connected directly to TX data input pins. AC coupling from pins into laser driver IC.
2. Voltage swing for 1G operation is equivalent to voltage swing in 10G operation (SFF-8431 Rev 4.1).
3. Into 100Ω differential termination. Voltage swing for 1G operation is equivalent to voltage swing in 10G operation (SFF-8431 Rev 4.1).
4. 20 – 80 % . Measured with Module Compliance Test Board and OMA test pattern. Use of four 1's and four 0's in sequence in the PRBS⁹ is an acceptable alternative. SFF-8431 Rev 4.1
5. LOS is an open collector output. Should be pulled up with 4.7kΩ – 10kΩ on the host board. Normal operation is logic 0; loss of signal is logic 1. Maximum pull-up voltage is 5.5V.
6. Testing methodology per SFF-8431. Rev 4.1.

IV. Optical Characteristics for RS0 = LOW (1G Operation)(T_{OP} = -5 to 70 °C, V_{CC} = 3.14 to 3.46 Volts)

Parameter	Symbol	Min	Typ	Max	Unit	Ref.
Transmitter						
Average Launch Power	P _{AVE}	-9.5		-1	dBm	1
Optical Wavelength	λ	840	850	860	nm	2
Rise-Fall Time	T _{rise} /T _{fall}			0.26	ns	3
RMS Spectral Width	$\Delta\lambda_{rms}$			0.45	dB	
Optical Extinction Ratio	ER	9			dB	
Average Launch power of OFF transmitter	P _{OFF}			-30	dBm	
Tx Jitter	T _{Xj}	Per IEEE 802.3-2012 Table 38-10				
Relative Intensity Noise	RIN ₁₂ OMA			-117	dB/Hz	
Coupled Power Ratio	CPR	9			dB	
Receiver						
Wavelength Range	λ_C	840		860	nm	2
Receiver Sensitivity	R _{SENS}	-17			dBm	
Stressed Receiver Sensitivity 50 μ m MMF	SRS _{50um}			-13.5	dBm	4
Stressed Receiver Sensitivity 62.5 μ m MMF	SRS _{62um}			-12.5	dBm	4
Maximum Input Power	P _{MAX}	+0.5			dBm	
Return Loss	R _{rx}	12			dB	
Receive electrical 3dB upper cutoff frequency			1500		MHz	2
LOS De-Assert	LOS _D			-18	dBm	
LOS Assert	LOS _A	-30	-23		dBm	
LOS Hysteresis		0.5			dB	

Notes:

1. Max is equivalent to 10G max spec.
2. This product has not been designed to support 780-nm laser operation.
3. 20%-80%.
4. Per IEEE 802.3-2012. 9dB extinction ratio transmitter.

V. Optical Characteristics for RS0 = HIGH (10G Operation)(T_{OP} = -5 to 70 °C, V_{CC} = 3.14 to 3.46 Volts)

Parameter	Symbol	Min	Typ	Max	Unit	Ref.	
Transmitter							
Optical Modulation Amplitude (OMA)	P _{OMA}		-1.5		dBm	1	
Average Launch Power	P _{AVE}	-5		-1	dBm	2	
Optical Wavelength	λ	840	850	860	nm	1	
RMS Spectral Width	Δλ _{rms}			0.45	dB	1	
Optical Extinction Ratio	ER	3.0	5.5		dB		
Transmitter and Dispersion Penalty	TDP			3.9	dB		
Average Launch power of OFF transmitter	P _{OFF}			-30	dBm		
Tx Jitter	T _{Xj}	Per IEEE 802.3-2012 requirements					
Encircled Flux	<4.5μm			30	%	3	
	<19μm	86					
Relative Intensity Noise	RIN ₁₂ OMA			-128	dB/Hz		
Receiver							
Receiver Sensitivity (OMA) @ 10.3Gb/s	R _{SENS1}			-11.1	dBm	4	
Stressed Receiver Sensitivity (OMA) @ 10.3Gb/s	R _{SENS2}			-7.5	dBm	5	
Maximum Input Power	P _{MAX}	+0.5			dBm		
Wavelength Range	λ _C	840		860	nm		
Receiver Reflectance	R _{rx}			-12	dB		
LOS De-Assert	LOS _D			-14	dBm		
LOS Assert	LOS _A	-30	-23		dBm		
LOS Hysteresis		0.5			dB		

Notes:

1. Per Tradeoff Table 52.8, IEEE 802.3-2012
2. Average Power figures are informative only, per IEEE802.3-2012.
3. Measured into Type A1a (50/125 μm multimode) fiber per ANSI/TIA/EIA-455-203-2.
4. Measured with worst ER; BER<10⁻¹²; 2³¹ – 1 PRBS.
5. Per IEEE 802.3-2012.

VI. General Specifications

Parameter	Symbol	Min	Typ	Max	Units	Ref.
Bit Rate (RS0 = LOW)	BR		1.25		Gb/s	1
Bit Rate (RS0 = HIGH)	BR	9.95	10.3		Gb/s	2

Parameter		Symbol	Max. Supported Distance		Units
Distance			@ 1G	@ 10G	
Fiber Type	850nm OFL Bandwidth				
62.5 μ m	160 MHz-km	Lmax	220	26	m
	OM1 200 MHz-km		275	33	
50 μ m	400 MHz-km	Lmax	500	66	m
	OM2 500 MHz-km		550	82	
	OM3 2000 MHz-km		>550	300	
	OM4 4700 MHz-km		>550	400	

Notes:

- 1000BASE-SX. Tested with a $2^7 - 1$ PRBS. See Section I, Note 5 for RS0 conditions for 1.25Gb/s operation.
- 10GBASE-SR/SW. Tested with a $2^{31} - 1$ PRBS. See Section I, Note 5 for RS0 conditions for 10.3 Gb/s operation.

VII. Environmental Specifications

Finisar 850nm SFP transceivers have a commercial operating temperature range from -5°C to +70°C case temperature.

Parameter	Symbol	Min	Typ	Max	Units	Ref.
Case Operating Temperature	T _{op}	-5		70	°C	
Storage Temperature	T _{sto}	-40		85	°C	

VIII. Regulatory Compliance

Finisar transceivers are Class 1 Laser Products and comply with US FDA regulations. These products are certified by TÜV and CSA to meet the Class 1 eye safety requirements of EN (IEC) 60825 and the electrical safety requirements of EN (IEC) 60950. Copies of certificates are available at Finisar Corporation upon request.

IX. Digital Diagnostic Functions

Finisar FTLX8574D3BCV SFP+ transceivers support the 2-wire serial communication protocol as defined in the SFF-8472. It is very closely related to the E²PROM defined in the GBIC standard, with the same electrical specifications.

The standard SFP+ serial ID provides access to identification information that describes the transceiver's capabilities, standard interfaces, manufacturer, and other information.

Additionally, Finisar SFP+ transceivers provide an enhanced digital diagnostic monitoring interface, which allows real-time access to device operating parameters such as transceiver temperature, laser bias current, transmitted optical power, received optical power and transceiver supply voltage. It also defines a sophisticated system of alarm and warning flags, which alerts end-users when particular operating parameters are outside of a factory set normal range.

SFF-8472 defines a 256-byte memory map in E²PROM that is accessible over a 2-wire serial interface at the 8 bit address 1010000X (A0h). The digital diagnostic monitoring interface makes use of the 8 bit address 1010001X (A2h), so the originally defined serial ID memory map remains unchanged. The interface is identical to, and is thus fully backward compatible with both the GBIC Specification and the SFP Multi Source Agreement. The complete interface is described in Finisar Application Note AN-2030: "Digital Diagnostics Monitoring Interface for SFP Optical Transceivers".

The operating and diagnostics information is monitored and reported by a Digital Diagnostics Transceiver Controller (DDTC) inside the transceiver, which is accessed through a 2-wire serial interface. When the serial protocol is activated, the serial clock signal (SCL, Mod Def 1) is generated by the host. The positive edge clocks data into the SFP transceiver into those segments of the E²PROM that are not write-protected. The negative edge clocks data from the SFP transceiver. The serial data signal (SDA, Mod Def 2) is bi-directional for serial data transfer. The host uses SDA in conjunction with SCL to mark the start and end of serial protocol activation. The memories are organized as a series of 8-bit data words that can be addressed individually or sequentially.

For more information, please see the SFF-8472 documentation and Finisar Application Note AN-2030.

X. Digital Diagnostic Specifications

FTLX8574D3BCV transceivers can be used in host systems that require either internally or externally calibrated digital diagnostics.

Parameter	Symbol	Min	Typ	Max	Units	Ref.
Accuracy						
Internally measured transceiver temperature	DD _{Temperature}	-3		3	°C	
Internally measured transceiver supply voltage	DD _{Voltage}	-100		100	mV	
Measured TX bias current	DD _{Bias}	-10		10	%	1
Measured TX output power	DD _{Tx-Power}	-2		2	dB	
Measured RX received average optical power	DD _{Rx-Power}	-2		2	dB	
Dynamic Range for Rated Accuracy						
Internally measured transceiver temperature	DD _{Temperature}	-5		70	°C	
Internally measured transceiver supply voltage	DD _{Voltage}	3.14		3.46	V	
Measured TX bias current	DD _{Bias}	0		20	mA	
Measured TX output power	DD _{Tx-Power}	-9		-2.5	dBm	
Measured RX received average optical power	DD _{Rx-Power}	-20		0	dBm	
Max Reporting Range						
Internally measured transceiver temperature	DD _{Temperature}	-40		125	°C	
Internally measured transceiver supply voltage	DD _{Voltage}	2.8		4.0	V	
Measured TX bias current	DD _{Bias}	0		20	mA	
Measured TX output power	DD _{Tx-Power}	-10		-1	dBm	
Measured RX received average optical power	DD _{Rx-Power}	-22		0	dBm	

Notes:

1. Accuracy of Measured Tx Bias Current is 10% of the actual Bias Current from the laser driver to the laser.

XI. Two-Wire Interface ID: Data Fields – Address A0h

Byte 13 Rate Select Identifier has been assigned to equal 02h which most accurately reflects functionality for this product where rate select is enabled through the Rx Rate_Select pin, per SFF-8472 v11.1. Although SFF-8472 v11.1 indicates that setting Byte 13 as 02h specifies 8G/4G/2G rates, these rates do not apply to this product which operates at 1G/10G operation. A future revision of SFF-8472 may utilize unallocated values that better reflects Rx Rate_Select 1G/10G.

XII. Mechanical Specifications

Finisar FTLX8574D3BCV SFP+ transceivers are compatible with the SFF-8432⁷ specification for improved pluggable form factor, and shown here for reference purposes only. Bail color is beige.

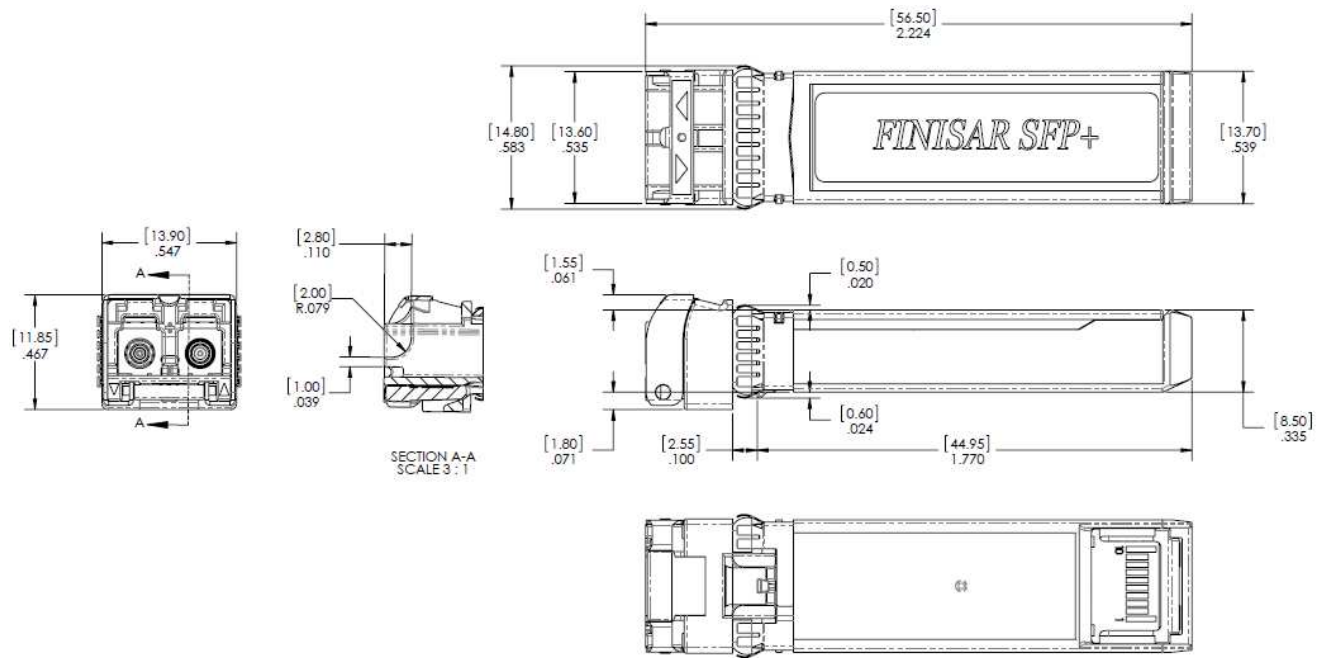

Figure 2. FTLX8574D3BCV Mechanical Dimensions.

XIII. PCB Layout and Bezel Recommendations

- ▲ Datum and Basic Dimension Established by Customer
- ▲ Pads and Vias are Chassis Ground, 11 Places
- ▲ Through Holes are Unplated

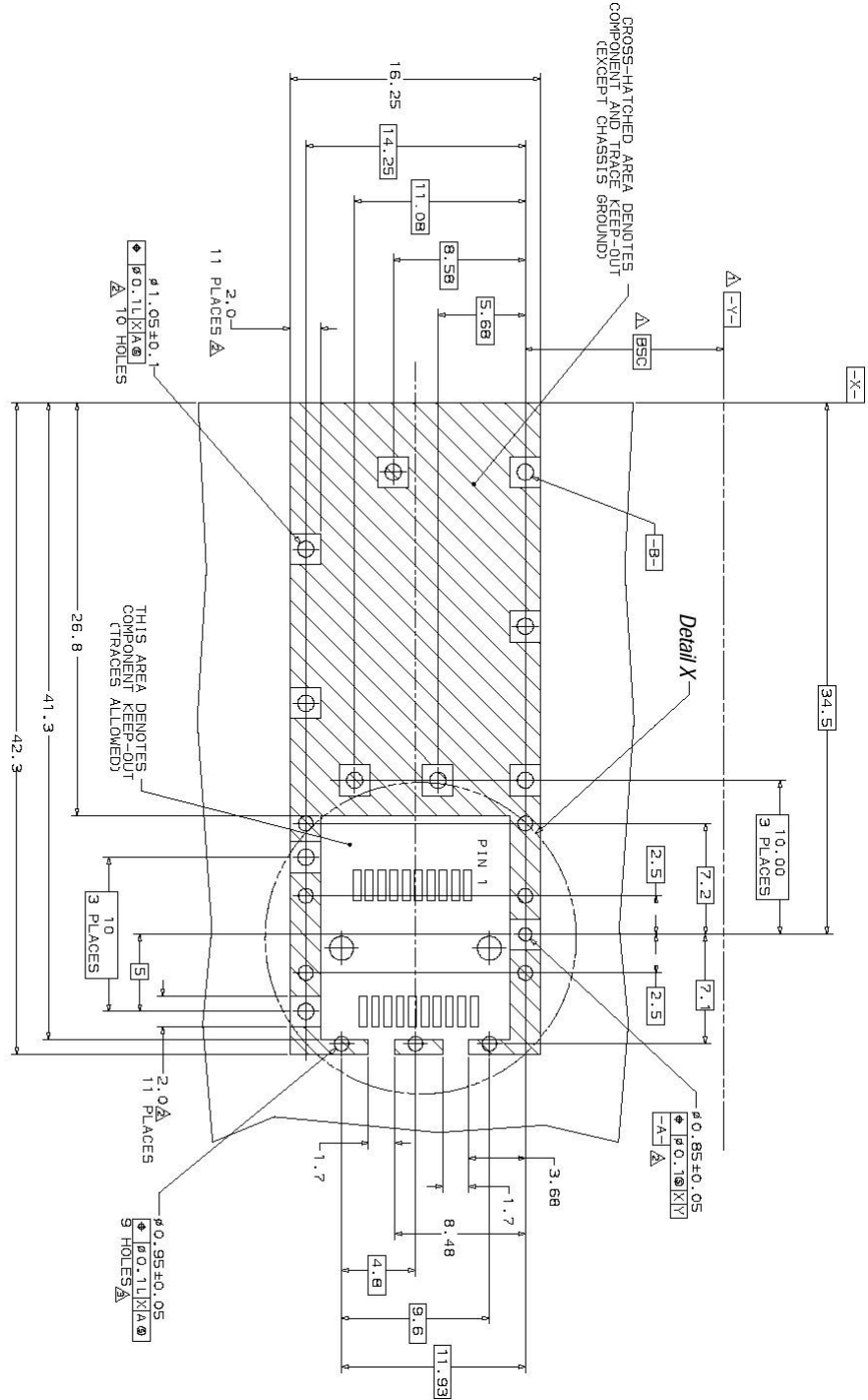
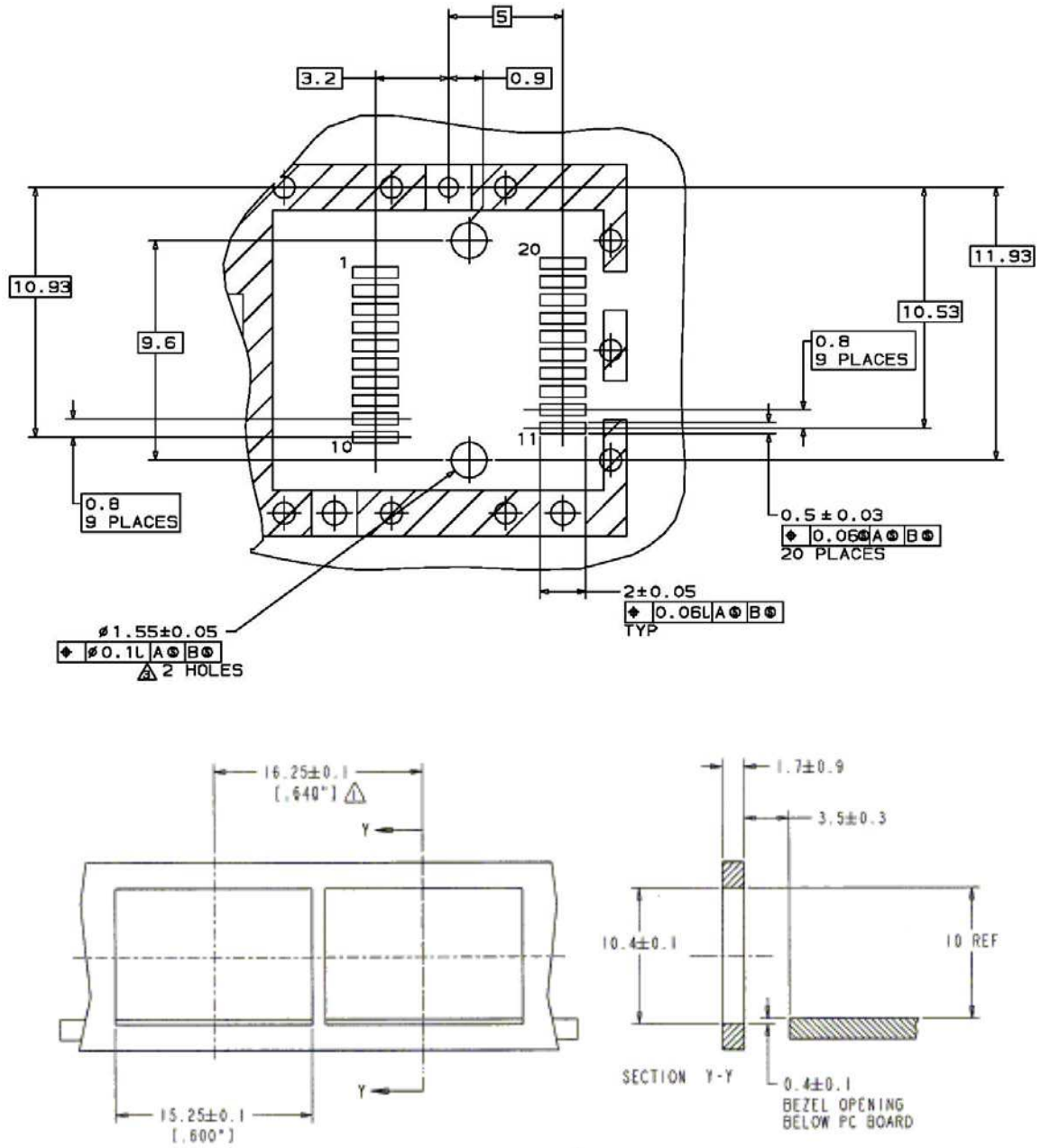

Figure 3.



- NOTES:
- MINIMUM PITCH ILLUSTRATED, ENGLISH DIMENSIONS ARE FOR REFERENCE ONLY
 - NOT RECOMMENDED FOR PCI EXPANSION CARD APPLICATIONS

Figure 4.

XIV. Host - Transceiver Interface Block Diagram

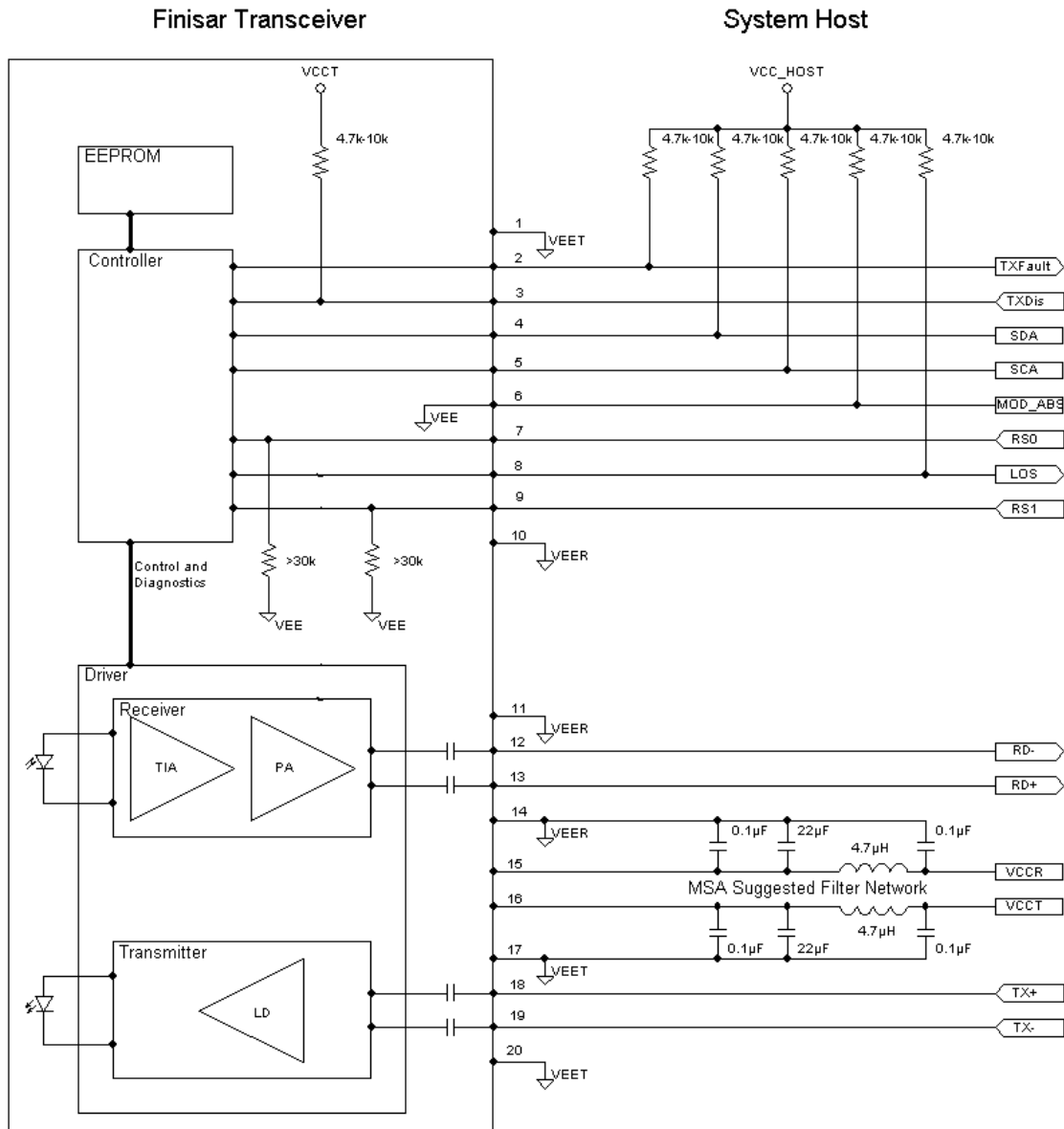

Figure 5. Host-Module Interface

XV. References

1. “Specifications for Enhanced 8.5 and 10 Gigabit Small Form Factor Pluggable Module ‘SFP+ ’”, SFF Document Number SFF-8431, Revision 4.1.
2. IEEE Std 802.3-2012, Clause 52, PMD Type 10GBASE-SR. IEEE Standards Department.
3. IEEE Std 802.3-2012, PMD Type 1000BASE-SX. IEEE Standards Department. This product has not been designed to support 780-nm laser operation.
4. “Digital Diagnostics Monitoring Interface for Optical Transceivers”. SFF Document Number SFF-8472, Revision 11.1.
5. Directive 2011/65/EU of the European Council Parliament and of the Council, “on the restriction of the use of certain hazardous substances in electrical and electronic equipment”.
6. “Application Note AN-2038: Finisar Implementation Of RoHS Compliant Transceivers”.
7. “Improved Pluggable Formfactor”, SFF Document Number SFF-8432, Revision 5.0.

XVI. For More Information

Finisar Corporation
1389 Moffett Park Drive
Sunnyvale, CA 94089-1133
Tel. 1-408-548-1000
Fax 1-408-541-6138
sales@finisar.com
www.finisar.com