



Chipsmall Limited consists of a professional team with an average of over 10 year of expertise in the distribution of electronic components. Based in Hongkong, we have already established firm and mutual-benefit business relationships with customers from,Europe,America and south Asia,supplying obsolete and hard-to-find components to meet their specific needs.

With the principle of “Quality Parts,Customers Priority,Honest Operation,and Considerate Service”,our business mainly focus on the distribution of electronic components. Line cards we deal with include Microchip,ALPS,ROHM,Xilinx,Pulse,ON,Everlight and Freescale. Main products comprise IC,Modules,Potentiometer,IC Socket,Relay,Connector.Our parts cover such applications as commercial,industrial, and automotives areas.

We are looking forward to setting up business relationship with you and hope to provide you with the best service and solution. Let us make a better world for our industry!



Contact us

Tel: +86-755-8981 8866 Fax: +86-755-8427 6832

Email & Skype: info@chipsmall.com Web: www.chipsmall.com

Address: A1208, Overseas Decoration Building, #122 Zhenhua RD., Futian, Shenzhen, China





Is Now Part of



ON Semiconductor®

To learn more about ON Semiconductor, please visit our website at
www.onsemi.com

ON Semiconductor and the ON Semiconductor logo are trademarks of Semiconductor Components Industries, LLC dba ON Semiconductor or its subsidiaries in the United States and/or other countries. ON Semiconductor owns the rights to a number of patents, trademarks, copyrights, trade secrets, and other intellectual property. A listing of ON Semiconductor's product/patent coverage may be accessed at www.onsemi.com/site/pdf/Patent-Marking.pdf. ON Semiconductor reserves the right to make changes without further notice to any products herein. ON Semiconductor makes no warranty, representation or guarantee regarding the suitability of its products for any particular purpose, nor does ON Semiconductor assume any liability arising out of the application or use of any product or circuit, and specifically disclaims any and all liability, including without limitation special, consequential or incidental damages. Buyer is responsible for its products and applications using ON Semiconductor products, including compliance with all laws, regulations and safety requirements or standards, regardless of any support or applications information provided by ON Semiconductor. "Typical" parameters which may be provided in ON Semiconductor data sheets and/or specifications can and do vary in different applications and actual performance may vary over time. All operating parameters, including "Typicals" must be validated for each customer application by customer's technical experts. ON Semiconductor does not convey any license under its patent rights nor the rights of others. ON Semiconductor products are not designed, intended, or authorized for use as a critical component in life support systems or any FDA Class 3 medical devices or medical devices with a same or similar classification in a foreign jurisdiction or any devices intended for implantation in the human body. Should Buyer purchase or use ON Semiconductor products for any such unintended or unauthorized application, Buyer shall indemnify and hold ON Semiconductor and its officers, employees, subsidiaries, affiliates, and distributors harmless against all claims, costs, damages, and expenses, and reasonable attorney fees arising out of, directly or indirectly, any claim of personal injury or death associated with such unintended or unauthorized use, even if such claim alleges that ON Semiconductor was negligent regarding the design or manufacture of the part. ON Semiconductor is an Equal Opportunity/Affirmative Action Employer. This literature is subject to all applicable copyright laws and is not for resale in any manner.



FUSB340

USB 3.1 SuperSpeed 10 Gbps Switch

Features

- 10 GHz Typical Bandwidth
- USB 3.1 SuperSpeed 5 Gbps and 10 Gbps Switch
- -1.0 dB Typical Insertion Loss at 2.5 GHz
- Low Active Power of 12 μ A Typical
- Low Shutdown Power of < 1 μ A Max.
- 2 kV HBM ESD Protection
- Small Packaging, 18 Lead TMLP
- Wide V_{DD} Operating Range, 1.5 V-5.0 V

Applications

- Smartphones
- Tablets
- Notebooks

Description

The FUSB340 is a 2:1 data switch for USB SuperSpeed Gen1 and Gen2, 5 Gbps and 10 Gbps data. It is targeted at the mobile device market and for use in Type-C applications where a reversible cable requires a switch.

The FUSB340 data switch offers superior performance various high speed data transmission protocols:

- USB 3.1 SuperSpeed (Gen 2), 10 Gbps
- PCI Express, Gen 3
- SATA
- Fibre Channel
- Display Port 1.3

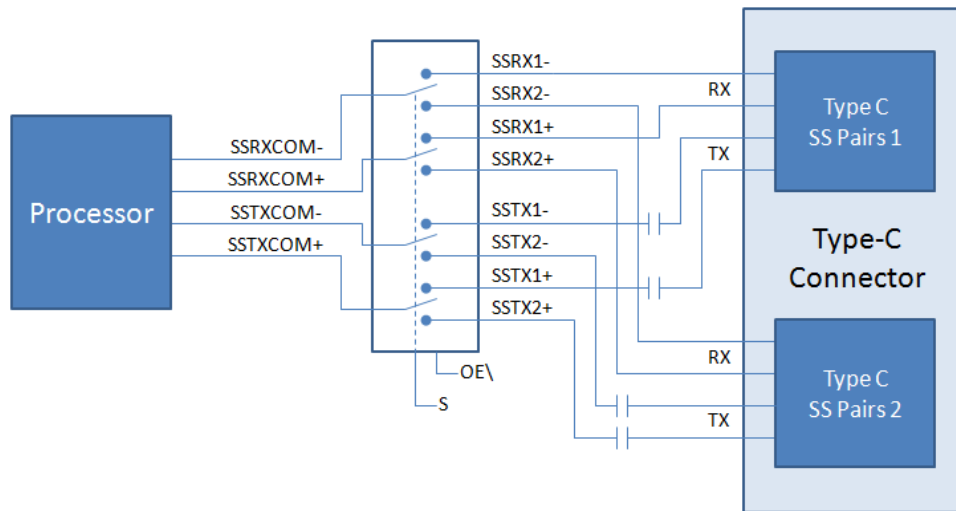

Figure 1. Block Diagram

Ordering Information

Part Number	Operating Temperature Range	Package	Packing Method
FUSB340TMX	-40 to 85°C	18-Lead, Quad, Ultra-ultrathin Molded Leadless Package (TMLP), 2.0 mm x 2.8 mm x 0.375 mm	Tape and Reel

Typical Application

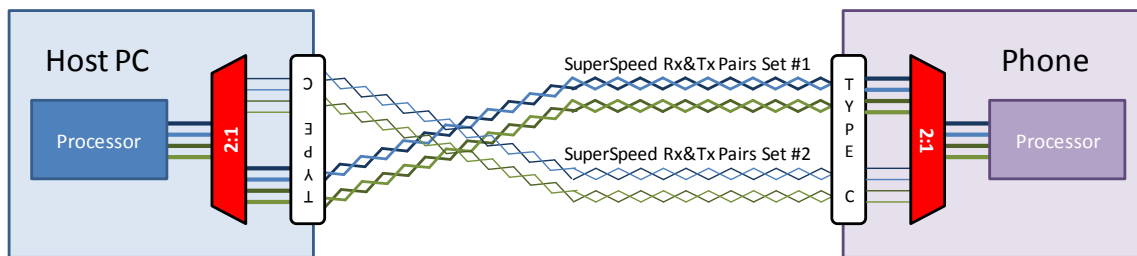

Figure 2. Typical Application

Pin Configuration

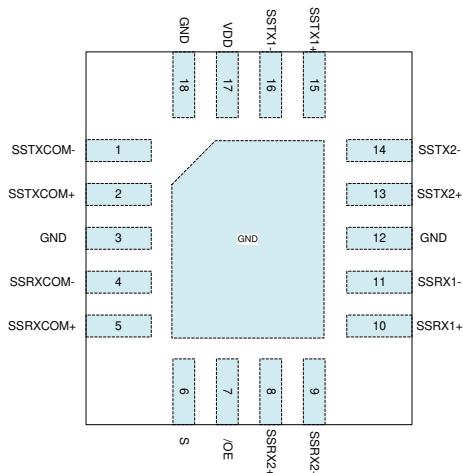

Figure 3. Pin Assignment (Top Through View)

Pin Descriptions

Pin #	Name	Type	Description
1	SSTXCOM-	SW	SuperSpeed TX- Common
2	SSTXCOM+	SW	SuperSpeed TX+ Common
3	GND	GND	Ground (connected to die attach pad)
4	SSRXCOM-	SW	SuperSpeed RX- Common
5	SSRXCOM+	SW	SuperSpeed RX+ Common
6	S	Input	Switch Select (0=SW1, 1=SW2)
7	/OE	Input	Output Enable (0=Switches Enabled, 1=Switches Disabled)
8	SSRX2+	SW	SuperSpeed RX2+
9	SSRX2-	SW	SuperSpeed RX2-
10	SSRX1+	SW	SuperSpeed RX1+
11	SSRX1-	SW	SuperSpeed RX1-
12	GND	GND	Ground (connected to die attach pad)
13	SSTX2+	SW	SuperSpeed TX2+
14	SSTX2-	SW	SuperSpeed TX2-
15	SSTX1+	SW	SuperSpeed TX1+
16	SSTX1-	SW	SuperSpeed TX1-
17	V _{DD}	VDD	Device Power
18	GND	GND	Ground

Absolute Maximum Ratings

Stresses exceeding the absolute maximum ratings may damage the device. The device may not function or be operable above the recommended operating conditions and stressing the parts to these levels is not recommended. In addition, extended exposure to stresses above the recommended operating conditions may affect device reliability. The absolute maximum ratings are stress ratings only.

Symbol	Parameter		Min.	Max.	Unit
V _{DD}	Supply Voltage		-0.5	6.0	V
V _{CNTRL}	DC Input Voltage (S, /OE) ⁽¹⁾		-0.5	V _{DD}	V
V _{SW}	DC Switch I/O Voltage ^(1,2)		-0.3	2.1	V
I _{IK}	DC Input Diode Current		-50		mA
I _{sw}	DC Switch Current			25	mA
T _{STG}	Storage Temperature		-65	+150	°C
MSL	Moisture Sensitivity Level (JEDEC J-STD-020A)			1	
ESD	Human Body Model, JEDEC: JESD22-A114	All Pins	2		kV
	IEC 61000-2-4, Level 4, for Switch Pins	Contact	8		
		Air	15		
	Charged Device Model, JESD22-C101		1		

Notes:

1. The input and output negative ratings may be exceeded if the input and output diode current ratings are observed.
2. V_{SW} refers to analog data switch paths.

Recommended Operating Conditions

The Recommended Operating Conditions table defines the conditions for actual device operation. Recommended operating conditions are specified to ensure optimal performance to the datasheet specifications. Fairchild does not recommend exceeding them or designing to Absolute Maximum Ratings.

Symbol	Parameter		Min.	Max.	Unit
V _{DD}	Supply Voltage		1.5	5.0	V
t _{RAMP(VDD)}	Power Supply Slew Rate		100	1000	μs/V
V _{CNTRL}	Control Input Voltage (S, /OE) ⁽³⁾		0	5.0	V
V _{SW}	Switch I/O Voltage (Both SSUSB Switch Paths)		0	2.0	V
T _A	Operating Temperature		-40	+85	°C

Note:

3. The control inputs must be held HIGH or LOW; they must not float.

DC and Transient Characteristics

All typical values are at $T_A=25^\circ\text{C}$ unless otherwise specified.

Symbol	Parameter	Condition	V_{DD} (V)	$T_A = -40^\circ\text{C}$ to $+85^\circ\text{C}$			Unit
				Min.	Typ.	Max.	
V_{IK}	Clamp Diode Voltage S, /OE	$I_{IN} = -18\text{ mA}$	1.5	-1.2		-0.6	V
I_{IK}	Clamp Diode Current (Switch Pins)	$V_{IN} = -0.3\text{ V}$	0			18	μA
V_{IH}	Control Input Voltage High	S, /OE	1.5	1.30			V
		S, /OE	3.6	1.4			V
		S, /OE	5.0	1.5			V
V_{IL}	Control Input Voltage Low	S, /OE	1.5			0.4	V
		S, /OE	3.6			0.4	V
		S, /OE	5.0			0.4	V
I_{IN}	Control Input Leakage	$V_{SW} = -0.6$ to 2.0 V $V_{CTRL} = 0$ to V_{DD}	5.0	-500		500	nA
I_{OZ}	Off-State Leakage for Open Data Paths	$V_{SW} = 0.0 \leq \text{DATA} \leq 2.0\text{ V}$	5.0	-0.5		0.5	μA
I_{CL}	On-State Leakage for Closed Data Paths ⁽⁴⁾	$V_{SW} = 0.0 \leq \text{DATA} \leq 2.0\text{ V}$	5.0	-0.5		0.5	μA
I_{OFF}	Power-Off Leakage Current (All I/O Ports)	$V_{SW} = 0\text{ V}$ or 2.0 V	0	-500		500	nA
R_{ON}	Switch On Resistance	$V_{SW} = 0\text{ V}$, $I_{ON} = -8\text{ mA}$	1.5		5.4	8.0	Ω
ΔR_{ON}	Difference in R_{ON} Between Positive-Negative	$V_{SW} = 0\text{ V}$, $I_{ON} = -8\text{ mA}$	1.5		0.1		Ω
R_{ONF}	Flatness for R_{ON}	$V_{SW} = 0 \leq \text{DATA} \leq 2.0\text{ V}$, $I_{ON} = -8\text{ mA}$	1.5		0.9		Ω
I_{CC}	Quiescent Supply Current	$V_{OE} = 0$, $V_{SEL} = 0$ or V_{DD} , $I_{OUT} = 0$	5.0		12	30	μA
I_{CCZ}	Quiescent Supply Current (High Impedance)	$V_{SEL} = X$, $V_{OE} = V_{DD}$, $I_{OUT} = 0$	5.0			1	μA
I_{CCT}	Increase in Quiescent Supply Current per V_{CTRL}	V_{SEL} or $V_{OE} = 1.5\text{ V}$	5.0		5	15	μA

Note:

4. For this test, the data switch is closed with the respective switch pin floating.

AC Electrical Characteristics

All typical value are for $V_{DD} = 3.6\text{ V}$ and $T_A = 25^\circ\text{C}$ unless otherwise specified.

Symbol	Parameter	Condition	V_{DD} (V)	$T_A = -40^\circ\text{C}$ to $+85^\circ\text{C}$			Unit
				Min.	Typ.	Max.	
t_{ON}	Turn-On Time, S to Output	$R_L = 50\ \Omega$, $C_L = 0\ \text{pF}$, $V_{SW} = 0\ \text{V}$, $V_{SW} = 0.6\ \text{V}$	1.5 to 5.0 V		350	600	ns
t_{OFF}	Turn-Off Time, S to Output	$R_L = 50\ \Omega$, $C_L = 0\ \text{pF}$, $V_{SW} = 0\ \text{V}$, $V_{SW} = 3.3\ \text{V}$	1.5 to 5.0 V		125	300	ns
$t_{ZHM,ZL}$	Enable Time, /OE to Output	$R_L = 50\ \Omega$, $C_L = 0\ \text{pF}$, $V_{SW} = 0.6\ \text{V}$	1.5 to 5.0 V		60	150	μs
$t_{LZM,HZ}$	Disable Time, /OE to Output	$R_L = 50\ \Omega$, $C_L = 0\ \text{pF}$, $V_{SW} = 0.6\ \text{V}$	1.5 to 5.0 V		35	240	ns
t_{PD}	Propagation Delay ⁽⁵⁾	$C_L =$, $C_L = 0\ \text{pF}$, $R_L = 50\ \Omega$,	1.5 to 5.0 V		0.25		ns
t_{BBM}	Break-Before-Make ⁽⁵⁾	$R_L = 50\ \Omega$, $C_L = 0\ \text{pF}$, $V_{SW1} = 0.6\ \text{V}$, $V_{SW2} = -0.6\ \text{V}$,	1.5 to 5.0 V	100		350	ns
DO_{IRR}	Differential Off Isolation ⁽⁵⁾	$V_S = 0\ \text{dBm}$, $R_L = 50\ \Omega$, $f = 2.5\ \text{GHz}$ $V_S = 0\ \text{dBm}$, $R_L = 50\ \Omega$, $f = 5.0\ \text{GHz}$	3.6 V		-28 -25		dB
SDD_{NEXT}	Differential Channel Crosstalk ⁽⁵⁾	$V_S = 0\ \text{dBm}$, $R = 50\ \Omega$, $f = 2.5\ \text{GHz}$ $V_S = 0\ \text{dBm}$, $R = 50\ \Omega$, $f = 5.0\ \text{GHz}$	3.6 V		-44 -40		dB
DIL	Differential Insertion Loss ⁽⁵⁾ (All Data Paths)	$V_{IN} = 0\ \text{dBm}$, $f = 2.5\ \text{GHz}$, $R_L = 50\ \Omega$, $C_L = 0\ \text{pF}$ $V_{IN} = 0\ \text{dBm}$, $f = 5.0\ \text{GHz}$, $R_L = 50\ \Omega$, $C_L = 0\ \text{pF}$	3.6 V		-1.0 -1.8		dB
BW	Differential -3 dB Bandwidth ⁽⁵⁾	$V_{IN} = 1\ \text{V}_{pk-pk}$, $R_L = 50\ \Omega$, $C_L = 0\ \text{pF}$, (Both Data Paths)	3.6 V		10		GHz
$t_{SK(P)}$	Skew of Opposite Transitions of the Same Output ⁽⁵⁾	$R_{PU} = 50\ \Omega$ to V_{DD} , $C_L = 0\ \text{pF}$	3.6 V		6		ps
C_{IN}	Control Pin Input Capacitance ⁽⁵⁾	$V_{DD} = 0\ \text{V}$, $f = 1\ \text{MHz}$			2.7		pF
C_{ON}	On Capacitance ⁽⁵⁾	$V_{DD} = 3.3\ \text{V}$, $f = 2.5\ \text{GHz}$			0.5		pF
C_{OFF}	Off Capacitance ⁽⁵⁾	$V_{DD} = 3.3\ \text{V}$, $f = 2.5\ \text{GHz}$			0.4		pF

Note:

- Guaranteed by characterization.

Eye Diagrams

All plots below are for $V_{DD}=3.6\text{ V}$ and $T_A=25^\circ\text{C}$ with 0 dBm differential data.

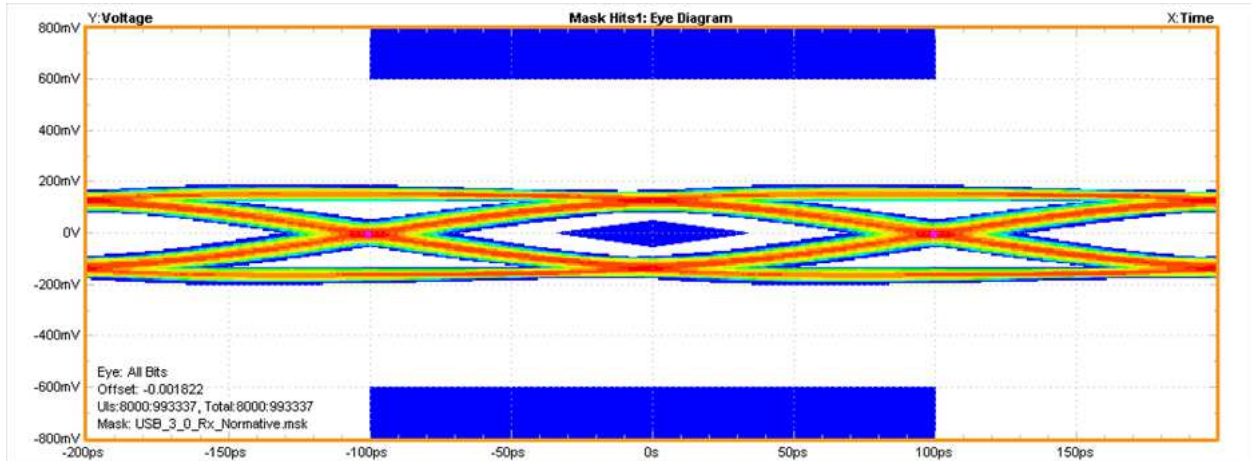

Figure 4. 5 Gbps Eye Diagram with Eye Mask

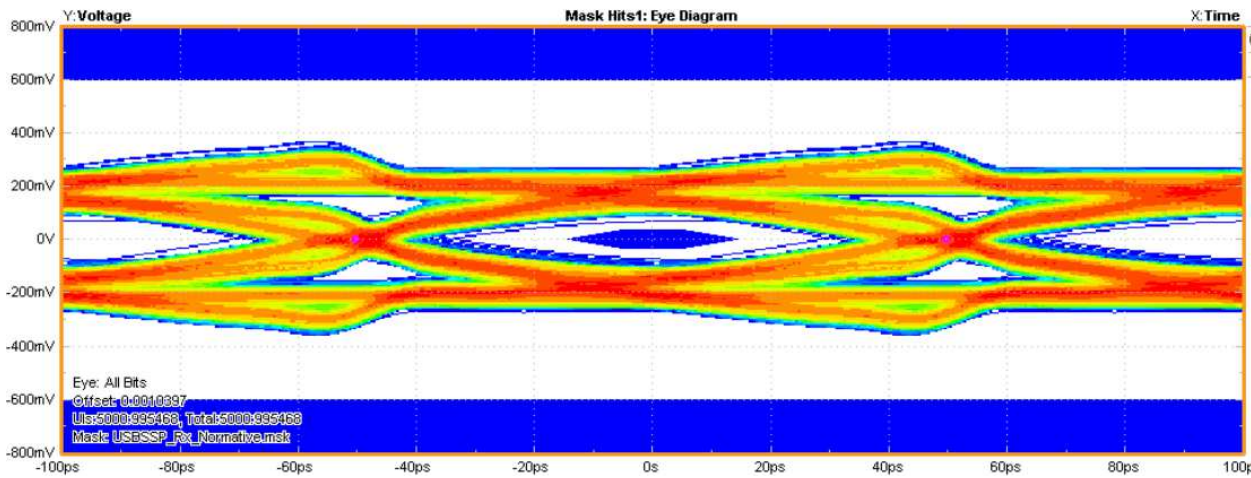
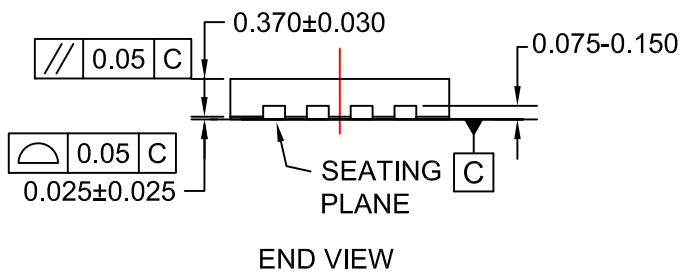
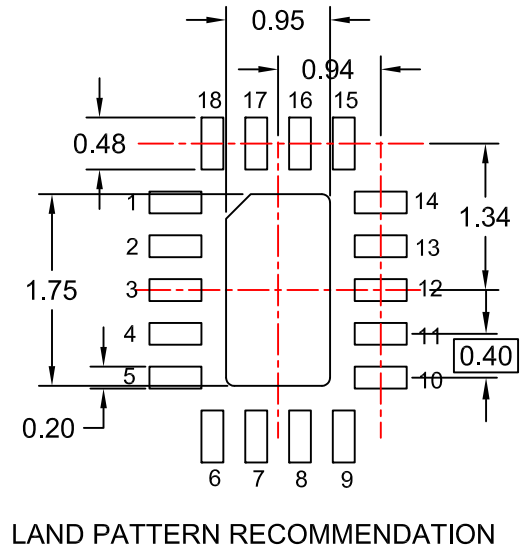
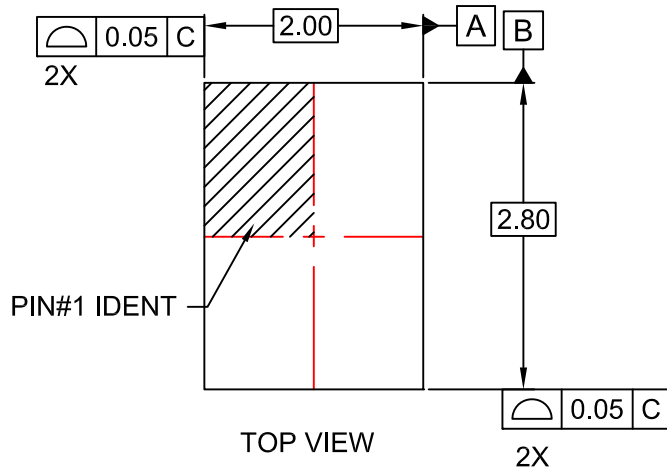

Figure 5. 10 Gbps Eye Diagram with Eye Mask

The table below pertains to the UMLP Package drawing on the following page.

Product-Specific Dimensions

Product	A	B
FUSB340TMX	2.00 mm	2.80 mm



NOTES:

- A. NO INDUSTRY STANDARD APPLIES.
- B. DIMENSIONS ARE IN MILLIMETERS.
- C. DIMENSIONS AND TOLERANCES PER ASME Y14.5M, 2009.
- D. LAND PATTERN RECOMMENDATION IS A FAIRCHILD DESIGN.
- E. DRAWING FILENAME: MKT-TMLP18Arev2

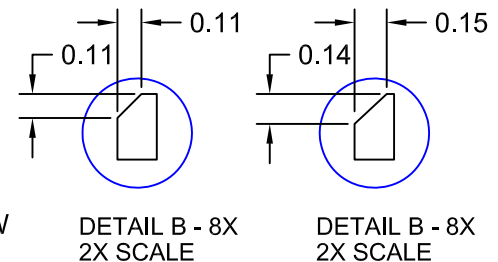
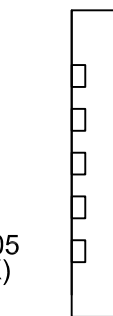
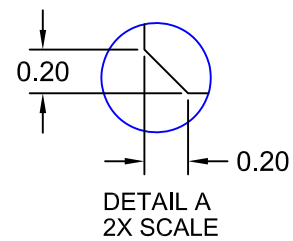
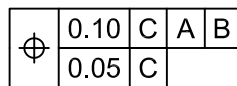
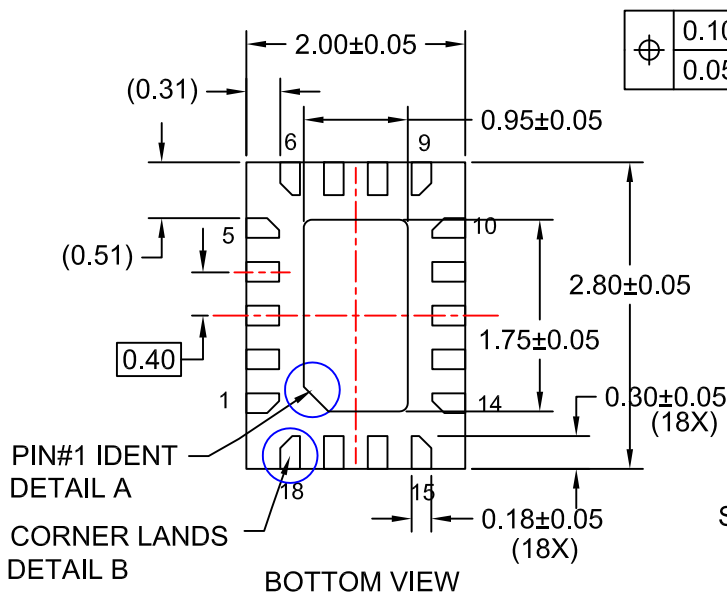

ON Semiconductor and  are trademarks of Semiconductor Components Industries, LLC dba ON Semiconductor or its subsidiaries in the United States and/or other countries. ON Semiconductor owns the rights to a number of patents, trademarks, copyrights, trade secrets, and other intellectual property. A listing of ON Semiconductor's product/patent coverage may be accessed at www.onsemi.com/site/pdf/Patent-Marking.pdf. ON Semiconductor reserves the right to make changes without further notice to any products herein. ON Semiconductor makes no warranty, representation or guarantee regarding the suitability of its products for any particular purpose, nor does ON Semiconductor assume any liability arising out of the application or use of any product or circuit, and specifically disclaims any and all liability, including without limitation special, consequential or incidental damages. Buyer is responsible for its products and applications using ON Semiconductor products, including compliance with all laws, regulations and safety requirements or standards, regardless of any support or applications information provided by ON Semiconductor. "Typical" parameters which may be provided in ON Semiconductor data sheets and/or specifications can and do vary in different applications and actual performance may vary over time. All operating parameters, including "Typicals" must be validated for each customer application by customer's technical experts. ON Semiconductor does not convey any license under its patent rights nor the rights of others. ON Semiconductor products are not designed, intended, or authorized for use as a critical component in life support systems or any FDA Class 3 medical devices or medical devices with a same or similar classification in a foreign jurisdiction or any devices intended for implantation in the human body. Should Buyer purchase or use ON Semiconductor products for any such unintended or unauthorized application, Buyer shall indemnify and hold ON Semiconductor and its officers, employees, subsidiaries, affiliates, and distributors harmless against all claims, costs, damages, and expenses, and reasonable attorney fees arising out of, directly or indirectly, any claim of personal injury or death associated with such unintended or unauthorized use, even if such claim alleges that ON Semiconductor was negligent regarding the design or manufacture of the part. ON Semiconductor is an Equal Opportunity/Affirmative Action Employer. This literature is subject to all applicable copyright laws and is not for resale in any manner.

PUBLICATION ORDERING INFORMATION

LITERATURE FULFILLMENT:

Literature Distribution Center for ON Semiconductor
19521 E. 32nd Pkwy, Aurora, Colorado 80011 USA
Phone: 303-675-2175 or 800-344-3860 Toll Free USA/Canada
Fax: 303-675-2176 or 800-344-3867 Toll Free USA/Canada
Email: orderlit@onsemi.com

N. American Technical Support: 800-282-9855 Toll Free
USA/Canada
Europe, Middle East and Africa Technical Support:
Phone: 421 33 790 2910
Japan Customer Focus Center
Phone: 81-3-5817-1050

ON Semiconductor Website: www.onsemi.com
Order Literature: <http://www.onsemi.com/orderlit>
For additional information, please contact your local
Sales Representative