



Chipsmall Limited consists of a professional team with an average of over 10 year of expertise in the distribution of electronic components. Based in Hongkong, we have already established firm and mutual-benefit business relationships with customers from,Europe,America and south Asia,supplying obsolete and hard-to-find components to meet their specific needs.

With the principle of “Quality Parts,Customers Priority,Honest Operation,and Considerate Service”,our business mainly focus on the distribution of electronic components. Line cards we deal with include Microchip,ALPS,ROHM,Xilinx,Pulse,ON,Everlight and Freescale. Main products comprise IC,Modules,Potentiometer,IC Socket,Relay,Connector.Our parts cover such applications as commercial,industrial, and automotives areas.

We are looking forward to setting up business relationship with you and hope to provide you with the best service and solution. Let us make a better world for our industry!



Contact us

Tel: +86-755-8981 8866 Fax: +86-755-8427 6832

Email & Skype: info@chipsmall.com Web: www.chipsmall.com

Address: A1208, Overseas Decoration Building, #122 Zhenhua RD., Futian, Shenzhen, China



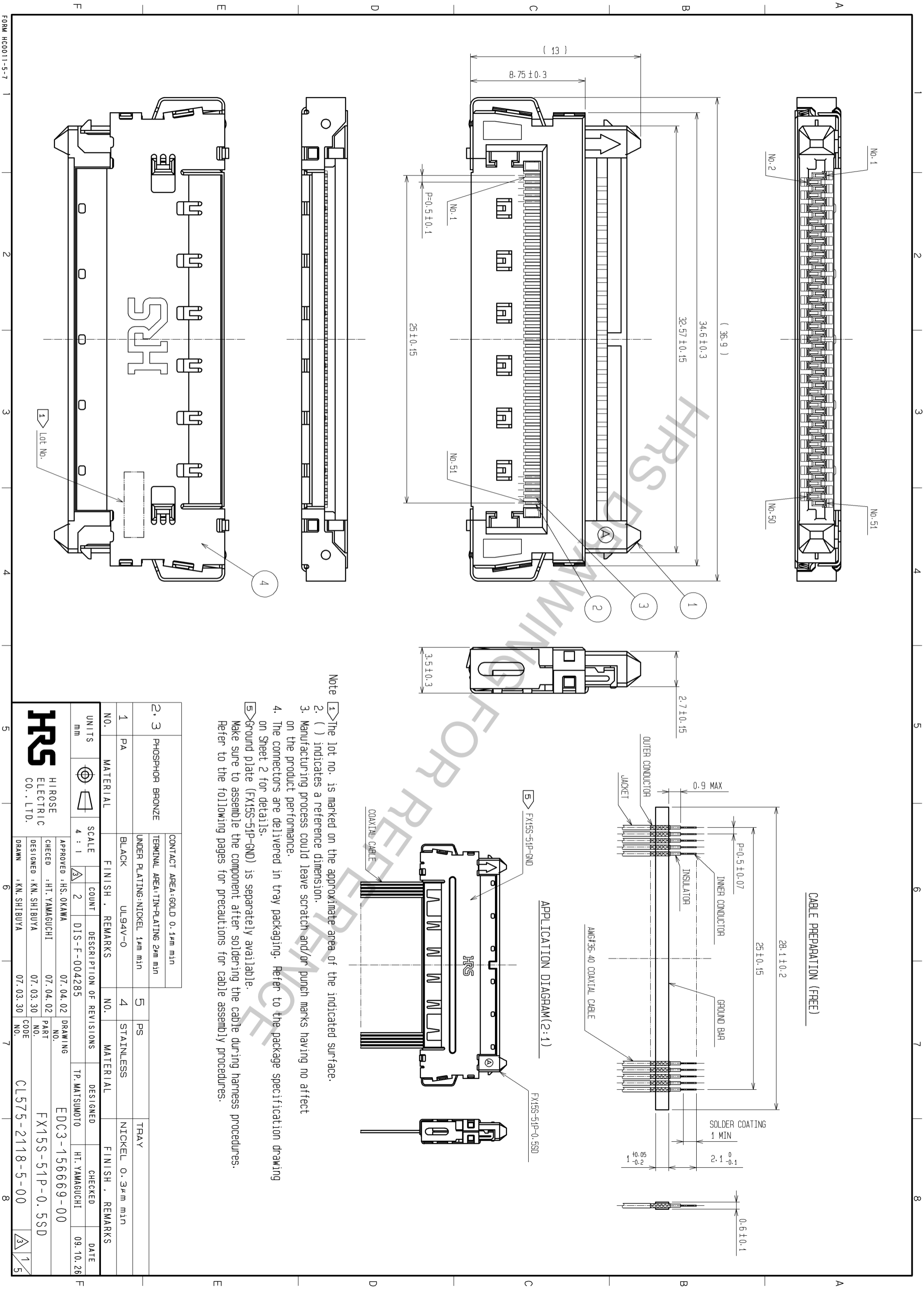

CABLE PREPARATION (FREE)

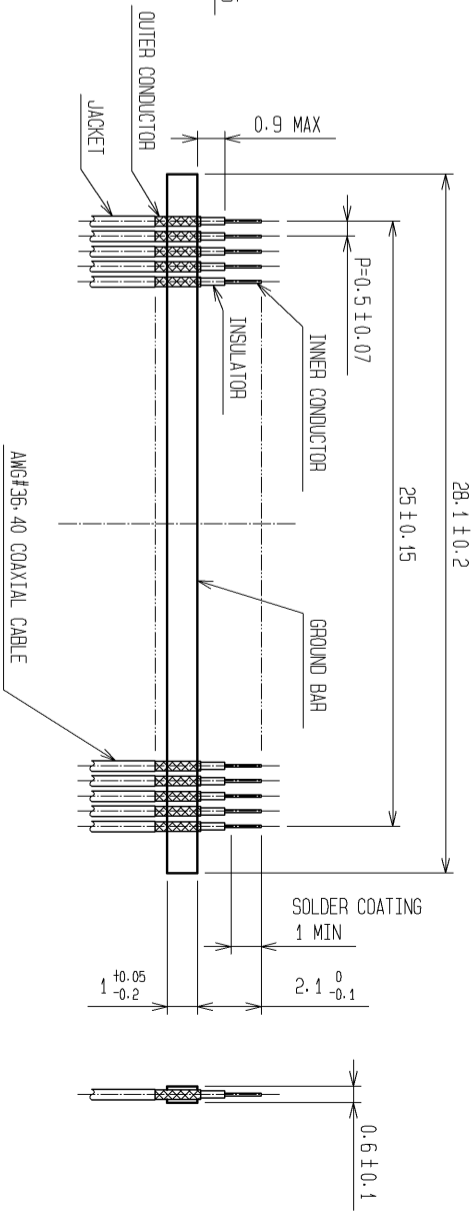

APPLICATION DIAGRAM(2:1)

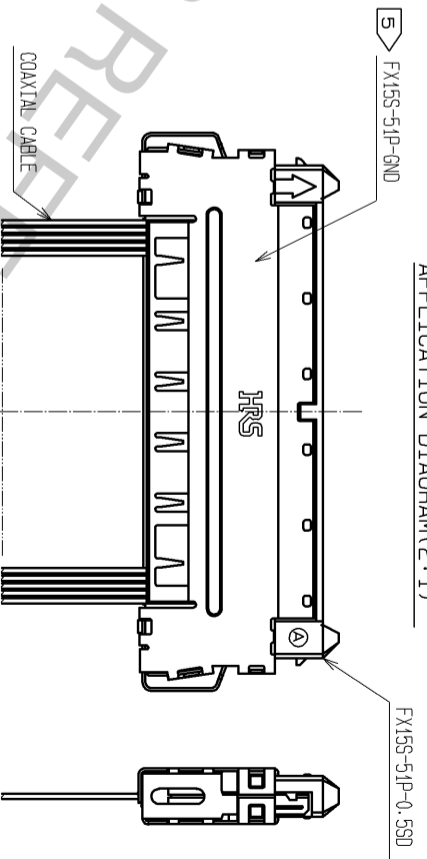

- Note
- 1 The lot no. is marked on the approximate area of the indicated surface.
 - 2 () indicates a reference dimension.
 - 3 Manufacturing process could leave scratch and/or punch marks having no affect on the product performance.
 - 4 The connectors are delivered in tray packaging. Refer to the package specification drawing on Sheet 2 for details.
 - 5 Ground plate (FX155-51P-GND) is separately available. Make sure to assemble the component after soldering the cable during harness procedures. Refer to the following pages for precautions for cable assembly procedures.

2, 3	PHOSPHOR BRONZE	CONTACT AREA: GOLD 0.1µm min TERMINAL AREA: TIN-PLATING 2µm min	5	PS	TRAY		
1	PA	UNDER PLATING: NICKEL 1µm min BLACK	4	STAINLESS	NICKEL 0.3µm min		
NO.	MATERIAL	FINISH	REMARKS	NO.	MATERIAL	FINISH	REMARKS
UNITS	SCALE	COUNT	DESCRIPTION OF REVISIONS	DESIGNED	CHECKED	DATE	
mm	4 : 1	2	DIS-F-004285	TP. MATSUMOTO	HT. YAMAGUCHI	09.10.26	

		HIROSE ELECTRIC CO., LTD.	
CHECKED	HT. YAMAGUCHI	07.04.02	PART NO.
DESIGNED	KN. SHIBUYA	07.03.30	CODE
DRAWN	KN. SHIBUYA	07.03.30	NO.
APPROVED	HS. OKAWA	07.04.02	DRAWING NO.
EDC3-156669-00			
FX155-51P-0.5SD			
CL575-2118-5-00			

DRAWING FOR PACKAGING(1:2)

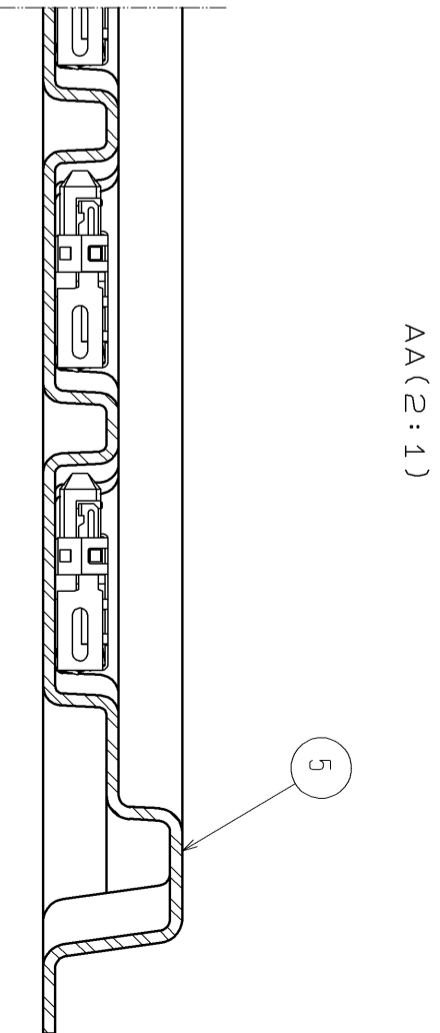
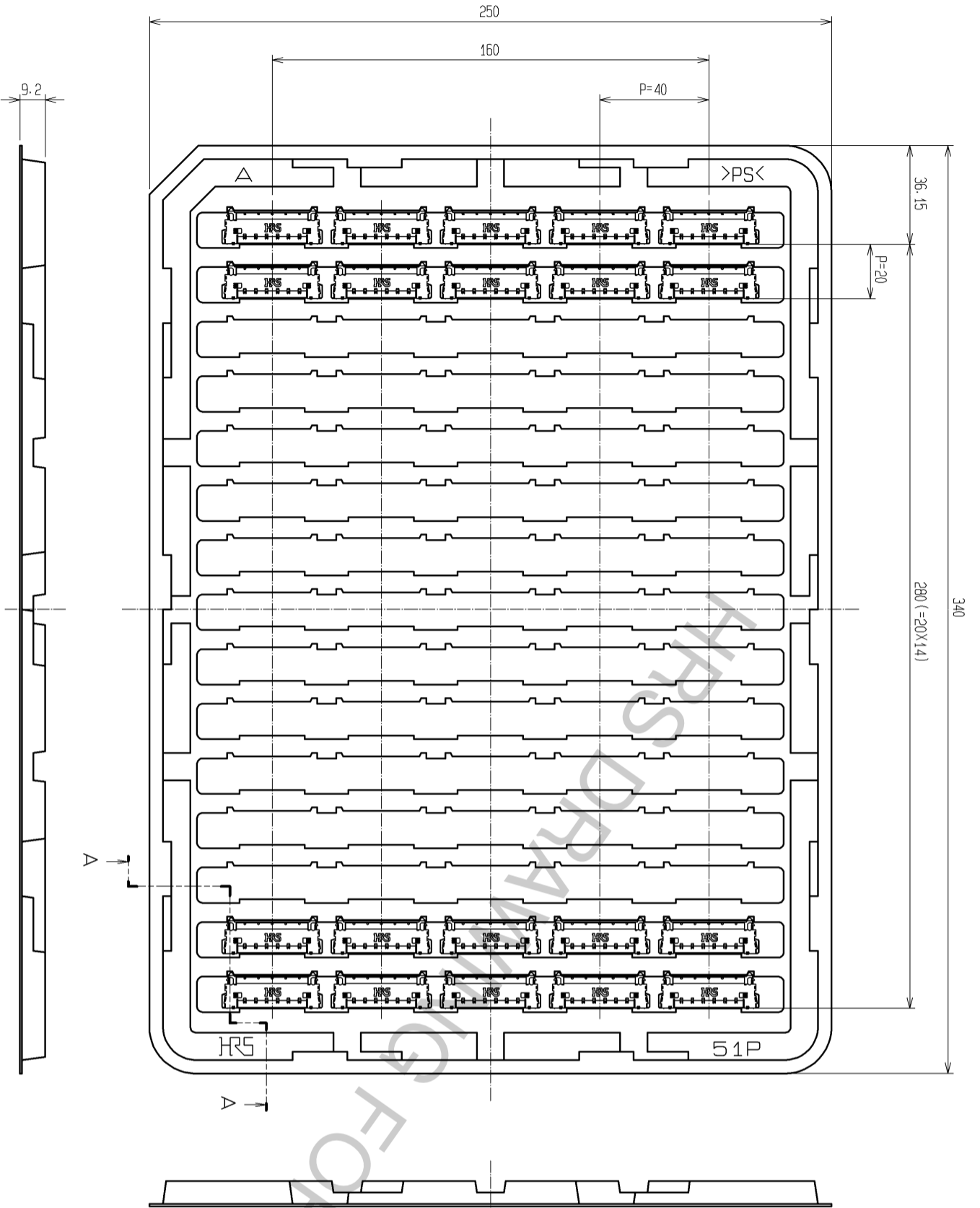

- Note
1. One tray contains 75 connectors.
 2. Connectors are arranged in tray packaging as shown in the figure. However, either connector surface can be the top.
 3. () indicates a reference dimension.

FORM HC0011-5-8

2

3

4

5

6

7

8

HRS	
DRAWING NO.	EDC3-156669-00
PART NO.	FX15S-51P-0.5SD
CODE NO.	CL575-2118-5-00
	3/2

This connector requires careful handling.
Please operate the connector with understanding of the following operation instructions.

Cautions for soldering

1. For the micro coaxial cable assembled to this connector, cable alignment process as shown in "Recommended cable" on the page 1 is required before assembly.

① Width of ground bar shall be 1.05 mm Max. including misalignment of overlapping, flush by cutting, side drop or soldering.

Using an inadequate cable will interfere the assembly to the connector. Forceful assembly and soldering could cause mis-soldering to defective product.

② Minimize the length of outer conductor beyond the ground bar.

③ Length of cutting the extra cable shall be 2.1 mm Max.

Its over length will cause the cable touching the connector body during assembly and cause defective product.

Minimal length 2.0 mm is a recommended dimension and allowed to be changed if necessary, as long as ensuring good solderability.

④ Pre-solder and coat the inner conductor at the cable end.

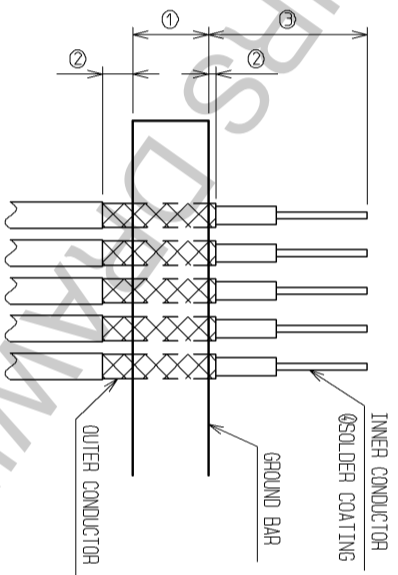

2. Recommended solder for the assembly is flux cored solder with 0.2 mm dia. (Lead-free: Sn-3Ag-0.5Cu), 26 mm length. If you consider using additional flux, please pay enough attention not to have flux wicking to the contact area. Flux wicking to the contact area will cause contact failure.

3. Place the cable to the connector and check the below points before soldering by cable assembly machine.

① Misalignment of cable end to the terminals in pitch direction

② Excessive floating of cable end

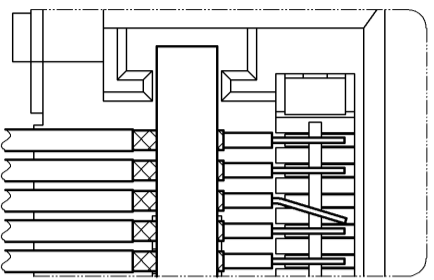

① Misalignment in pitch direction

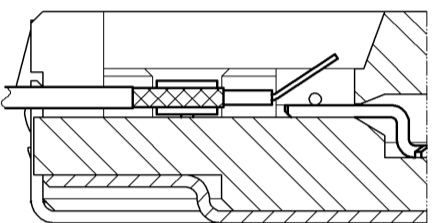

② Floating

4. Follow the recommended temperature profile shown below for the soldering.

However, the optimum condition could vary depending on various factors including type of cable and its length, solder type. Therefore refer to the recommended temperature profile and optimize the condition if necessary.

Solder tip pressurization	13~17 N
Heating	
Temperature	265± 5 °C
Duration	3~4 sec

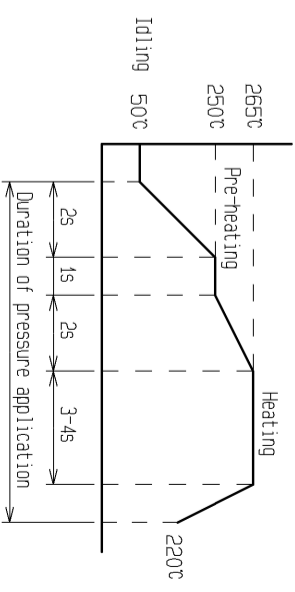

5. After soldering, check that no defect is found at soldered area. Examples of correct soldered and defective soldered state are shown below.

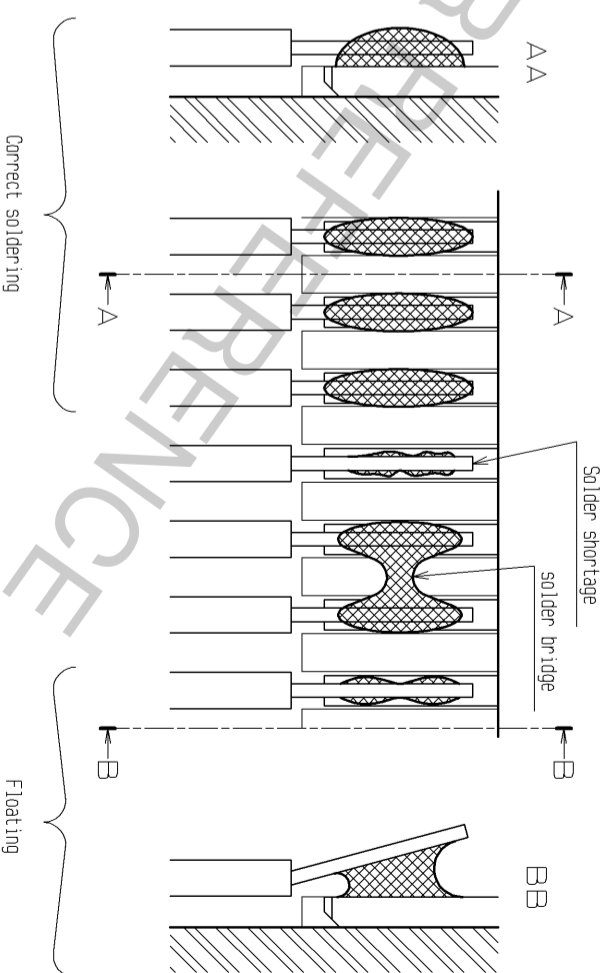

HRS

DRAWING NO.	EDC3-156669-00
PART NO.	FX15S-51P-0.5SD
CODE NO.	CL575-2118-5-00

3/5

Cautions for potting process

1. Protect the soldered area by UV cured resin (referred as "potting" hereafter), in order to prevent cable breakage during cabling and other troubles.
2. Apply 3033 manufactured by THREEBOND CO., LTD. or any equivalent product for potting. Follow the instruction of potting manufacturer's for the condition of UV exposure.
3. Refer to the following conditions for the potting area.

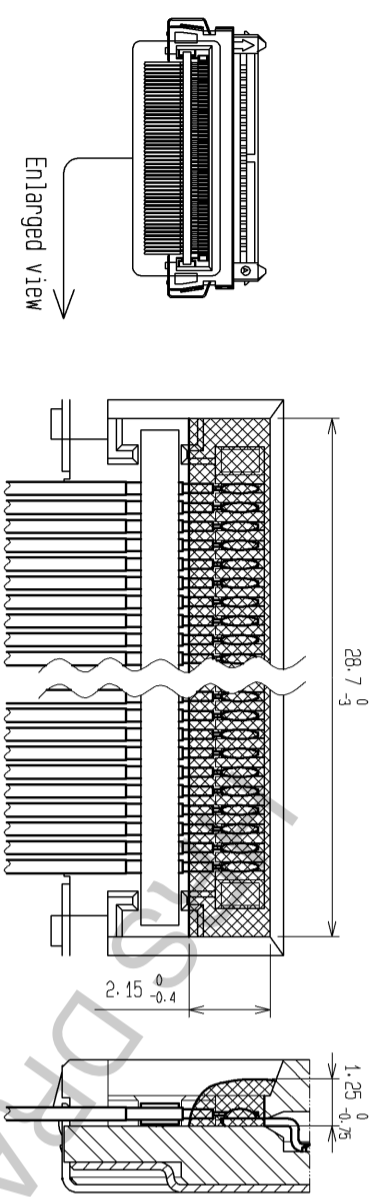

4. Use extreme care for the handling after soldering to the end of potting process not to apply stress to the cable, otherwise, cable could be broken.

Cautions for ground plate assembly

1. Attach a ground plate separately provided as FX15 xxx after the cable assembly process.
2. Place the ground plate onto the connector horizontally and pinch two components from top and bottom with fingers.

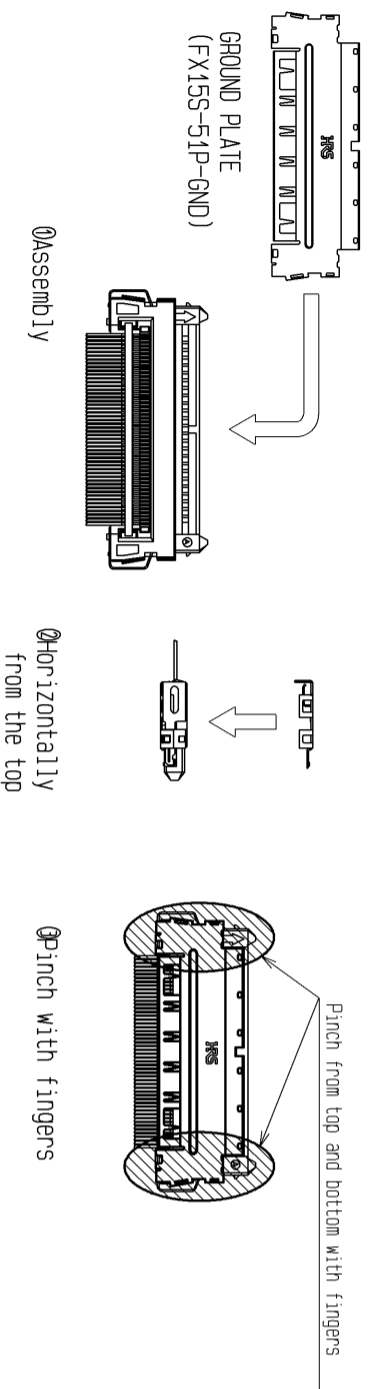

Cable assembly process is completed.

Soldering to ground plate

1. Solder down the metal bar of the cable and ground plate after the assembly of ground plate in order to enhance the grounding performance and robustness against cable stroke to up and down direction.

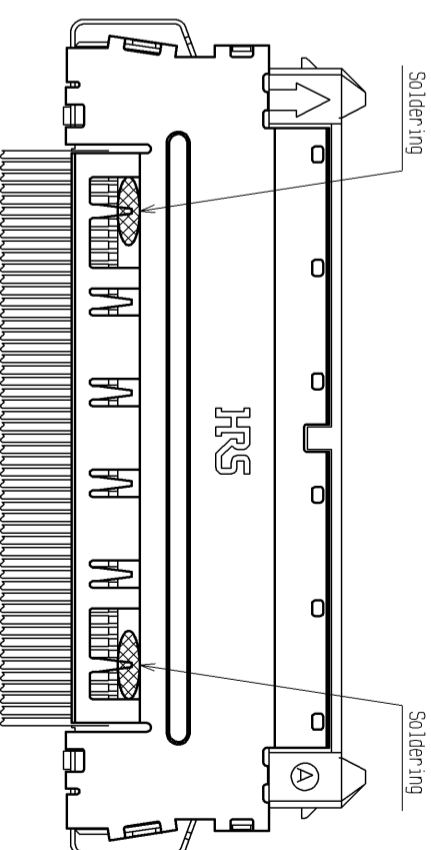

3. Check the six fitting points after assembly and make sure that they are all correctly fitted together.

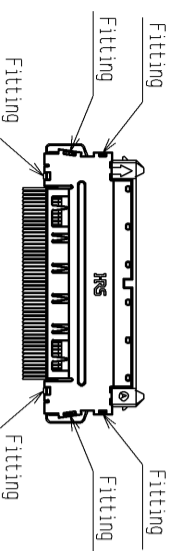

How to check fitting points
(Cut section of fitting points)

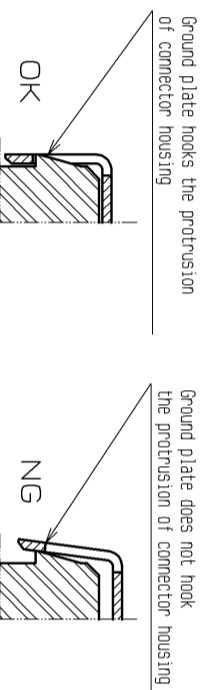

Cautions for mating with on-board connector

1. Insertion to on-board connector
The connector mating is keyed. Align the marks as shown in the figure for mating. Insert the connector completely until they are locked at both ends.

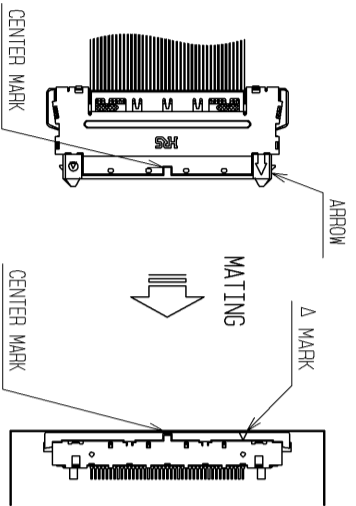

[EXAMPLE] RECEPTACLE: FX15S-**-S-0.5SH

The connectors have a reverse-insertion prevention structure, however, the connectors may be damaged when inserted reversely with the force of 25 N or more. Avoid a forceful insertion, and make sure to confirm that the connectors are aligned with the marks before the mating operation.

2. After mating

Carefully wire cables, so that excessive force will not be applied to the mated connectors. Pulling the cable with the force of 20 N or more may damage the connectors. It may also cause cable breakage.

Repetitive cable strokes could also cause cable breakage as well. Do not use the connector under the environment of repetitive cable strokes. Up to 10 times of up and down cable strokes are allowed for wiring process.

Take enough bend radius and/or distance from the connector for the cable not to apply stress to the connector base when the application requires cable bend back.

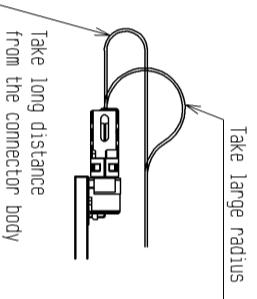
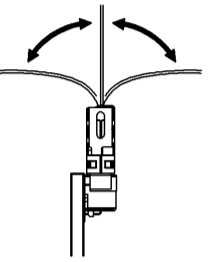
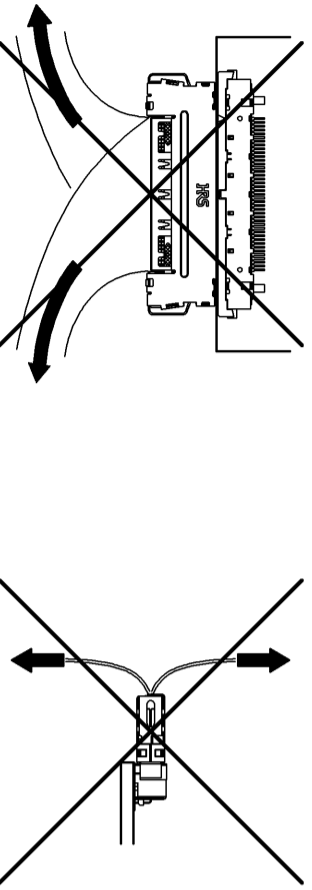

3. Withdrawal from on-board connector
The connectors are locked while they are mated. In order to unmate the connectors, pull the connector straight, with releasing the lock by pushing both sides of the connector. At this time, avoid pushing the base of button, which may deform the lock. And, do not pull the cable. Also, avoid the withdrawal in angle, which may damage the connectors.

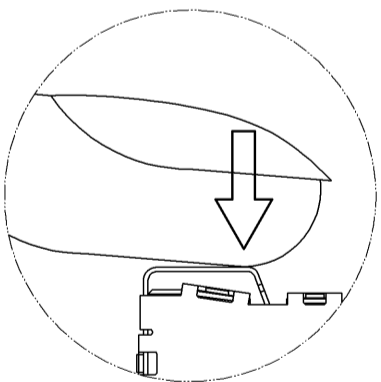
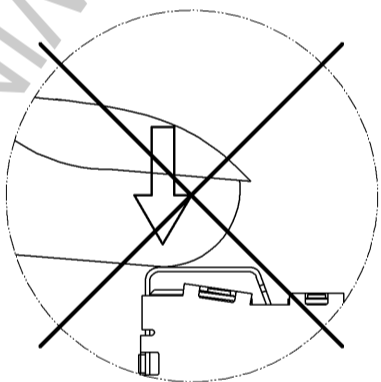

<Incorrect withdrawal>

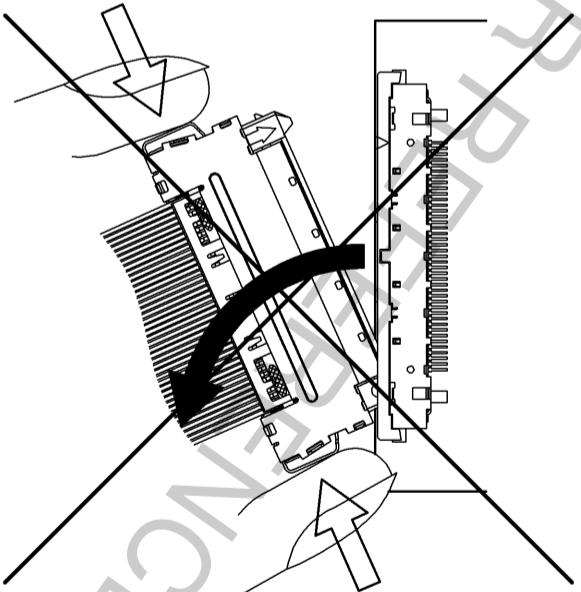

<Correct withdrawal>

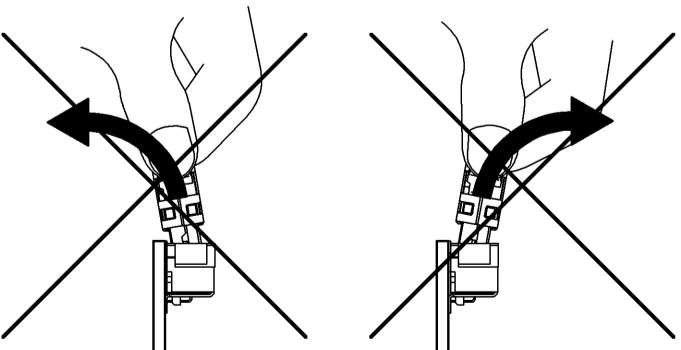
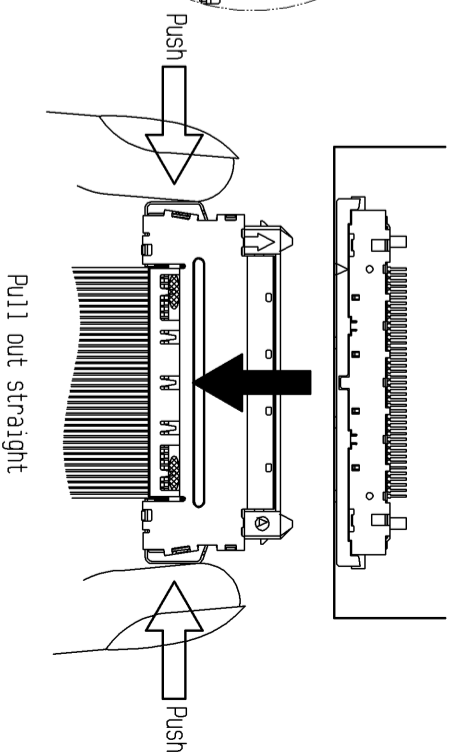

Cable stroke to up and down: up to 10 times

Application of cable bend back