



Chipsmall Limited consists of a professional team with an average of over 10 year of expertise in the distribution of electronic components. Based in Hongkong, we have already established firm and mutual-benefit business relationships with customers from,Europe,America and south Asia,supplying obsolete and hard-to-find components to meet their specific needs.

With the principle of “Quality Parts,Customers Priority,Honest Operation,and Considerate Service”,our business mainly focus on the distribution of electronic components. Line cards we deal with include Microchip,ALPS,ROHM,Xilinx,Pulse,ON,Everlight and Freescale. Main products comprise IC,Modules,Potentiometer,IC Socket,Relay,Connector.Our parts cover such applications as commercial,industrial, and automotives areas.

We are looking forward to setting up business relationship with you and hope to provide you with the best service and solution. Let us make a better world for our industry!



Contact us

Tel: +86-755-8981 8866 Fax: +86-755-8427 6832

Email & Skype: info@chipsmall.com Web: www.chipsmall.com

Address: A1208, Overseas Decoration Building, #122 Zhenhua RD., Futian, Shenzhen, China



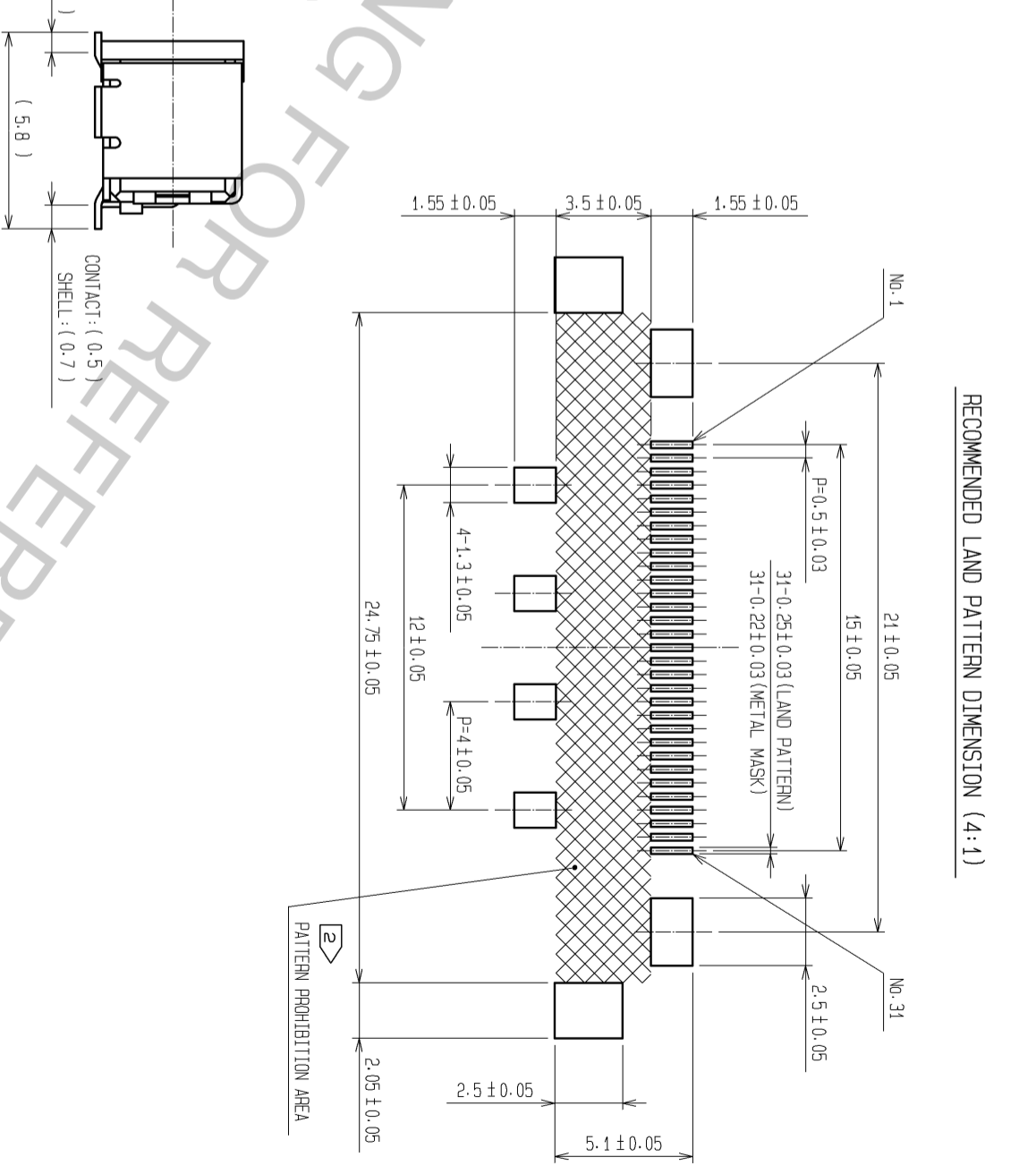
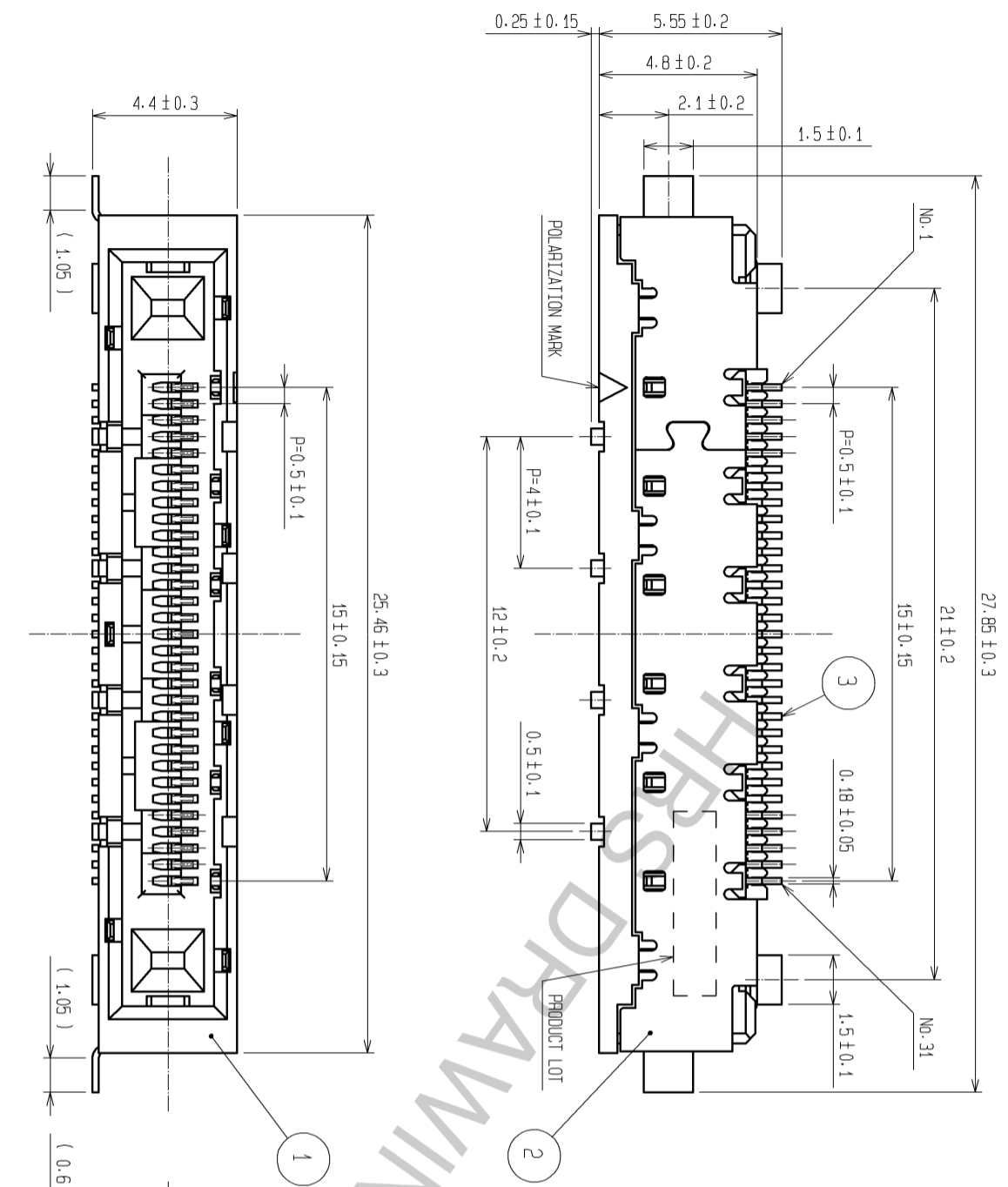

RECOMMENDED LAND PATTERN DIMENSION (4:1)

- NOTE
- 1 LEAD CO-PLANARITY OF THIS PRODUCT TO BE 0.1MAX.
 - 2 AREA OF INNER SMT LAND REQUIRES PATTERN PROHIBITION OR RESIST TREATMENT TO PREVENT THE PATTERN TOUCHING TO THE CONTACTS.
 - 3 () INDICATES A REFERENCE DIMENSION.
 - 4 MANUFACTURING PROCESS COULD LEAVE SCRATCH AND/OR PUNCH MARKS HAVING NO AFFECT ON THE PRODUCT PERFORMANCE.
 - 5 PACKAGING FOR THIS PRODUCT APPLIES EMBOSSED CARRIER TAPE PACKAGING. SEE SHEET 2/2 FOR DETAILS.

NO.	MATERIAL	FINISH . REMARKS	NO.	MATERIAL	FINISH . REMARKS
1	LCP	BLACK. UL94V-0	3	PHOSPHOR BRONZE	LEAD AREA: GOLD 0.03µm min
2	PHOSPHOR BRONZE	OVER PLATING: TIN PLATING 1µm min UNDER PLATING: NICKEL 0.2µm min	4	PS	(EMBOSSSED CARRIER TAPE)
5	PE	(COVER TAPE)			

UNITS	SCALE	COUNT	DESCRIPTION OF REVISIONS	DESIGNED	CHECKED	DATE
mm	5 : 1					

NO.	MATERIAL	FINISH . REMARKS
1	PHOSPHOR BRONZE	LEAD AREA: GOLD 0.03µm min
2	PHOSPHOR BRONZE	UNDER PLATING: NICKEL 1µm min

APPROVED	DESIGNED	CHECKED	DRAWN
HS. OKAWA	TS. MIYAKI	HT. YAMAGUCHI	TS. MIYAKI
11.09.15	11.09.15	11.09.15	11.09.15

DRAWING NO.	PART NO.	CODE
EDC3-157340-02	FX16-31S-0.5SH(30)	CL575-3412-8-30

DRAWING FOR PACKING(2:1)

THE DIRECTION OF PULLING OUT

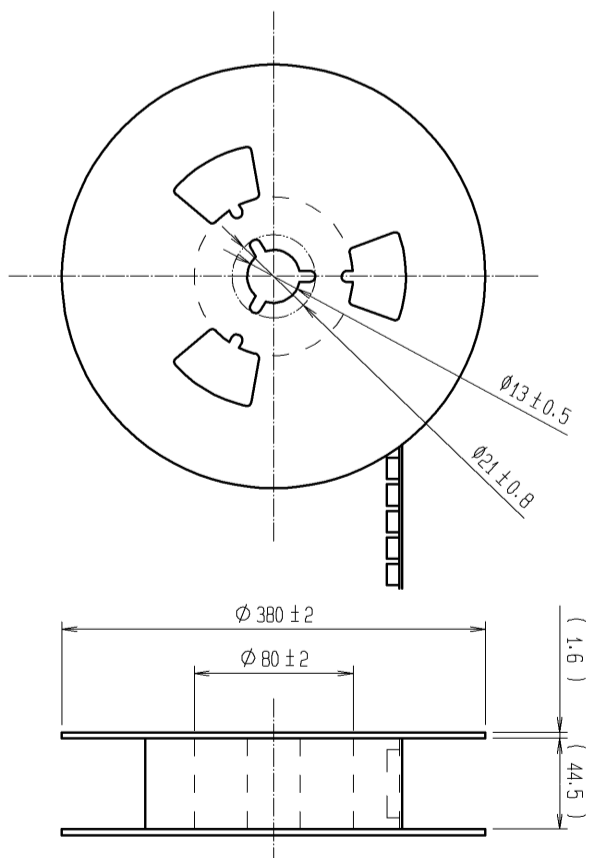
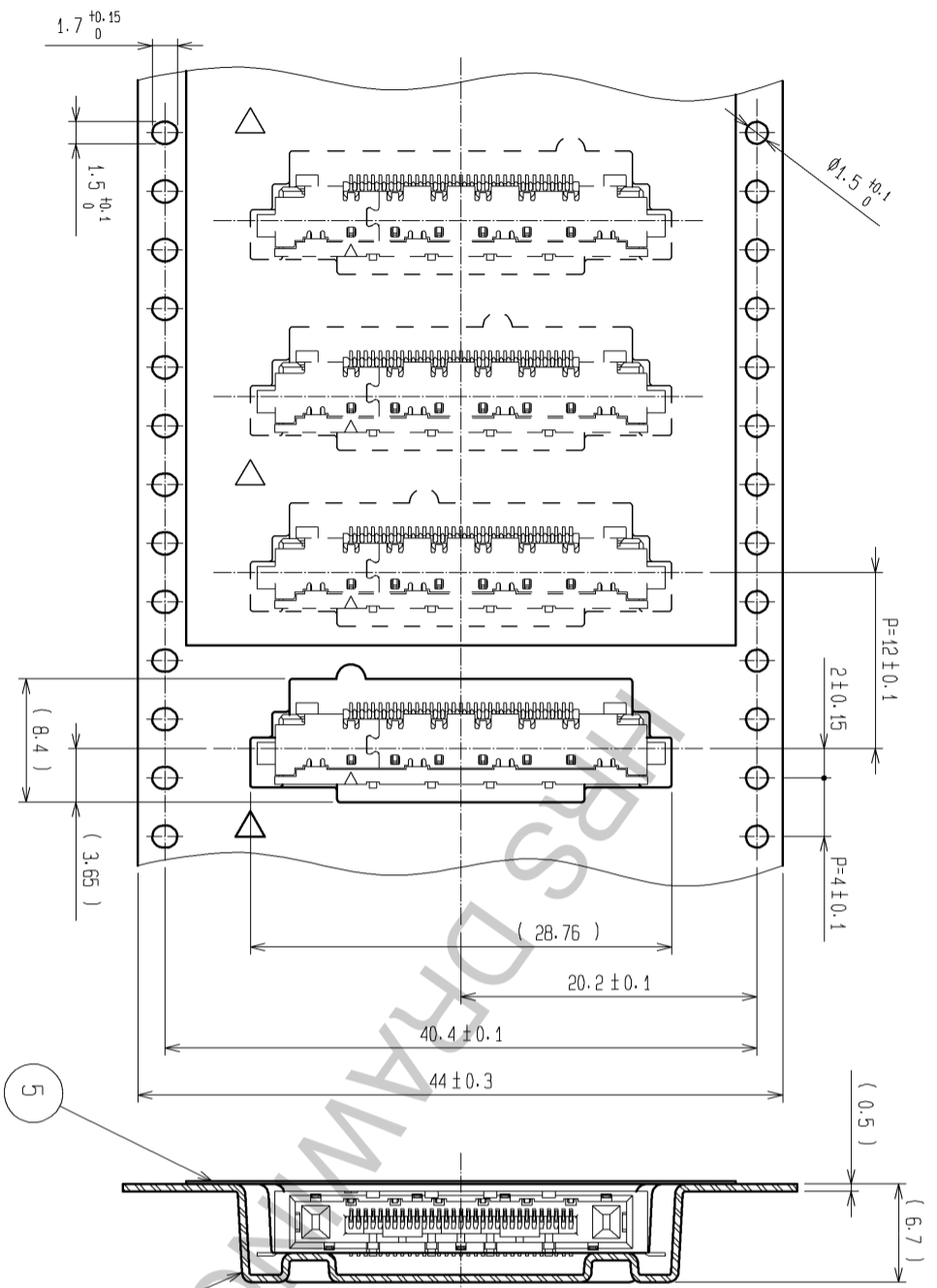
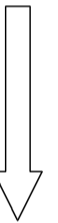

REELED DIMENSION (FREE)

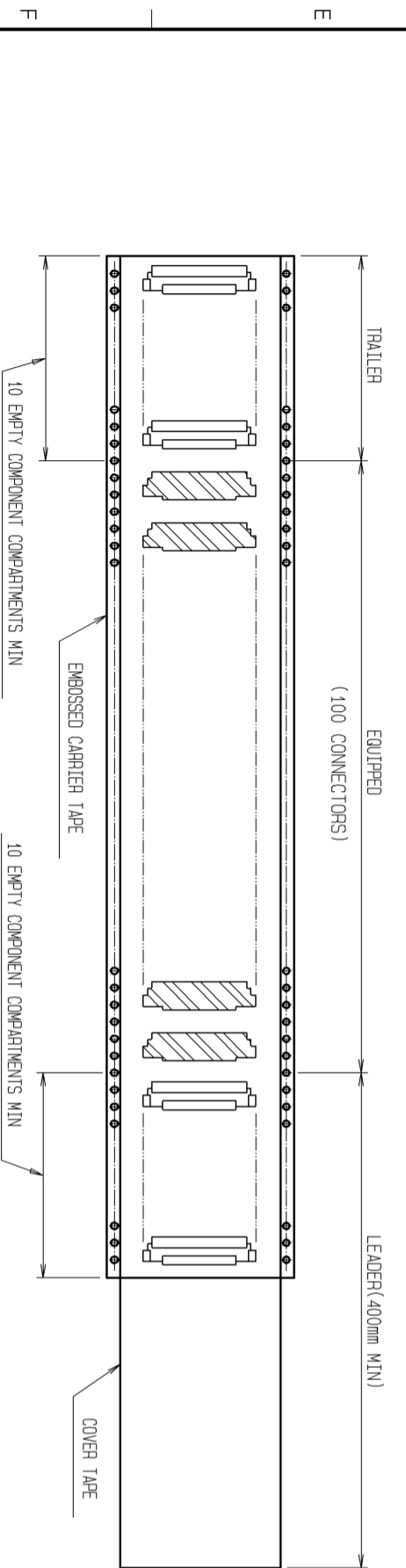
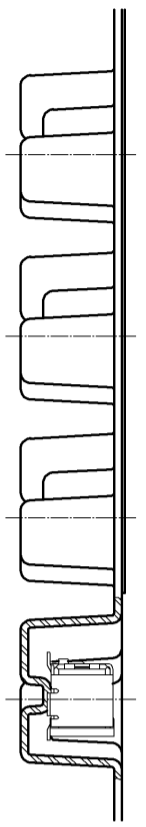

FOR REFERENCE

HR5	DRAWING NO.	EDC3-157340-02
	PART NO.	FX16-31S-0.5SH(30)
	CODE	CL575-3412-8-30
	NO.	2