



Chipsmall Limited consists of a professional team with an average of over 10 year of expertise in the distribution of electronic components. Based in Hongkong, we have already established firm and mutual-benefit business relationships with customers from,Europe,America and south Asia,supplying obsolete and hard-to-find components to meet their specific needs.

With the principle of “Quality Parts,Customers Priority,Honest Operation,and Considerate Service”,our business mainly focus on the distribution of electronic components. Line cards we deal with include Microchip,ALPS,ROHM,Xilinx,Pulse,ON,Everlight and Freescale. Main products comprise IC,Modules,Potentiometer,IC Socket,Relay,Connector.Our parts cover such applications as commercial,industrial, and automotives areas.

We are looking forward to setting up business relationship with you and hope to provide you with the best service and solution. Let us make a better world for our industry!



## Contact us

Tel: +86-755-8981 8866 Fax: +86-755-8427 6832

Email & Skype: info@chipsmall.com Web: www.chipsmall.com

Address: A1208, Overseas Decoration Building, #122 Zhenhua RD., Futian, Shenzhen, China



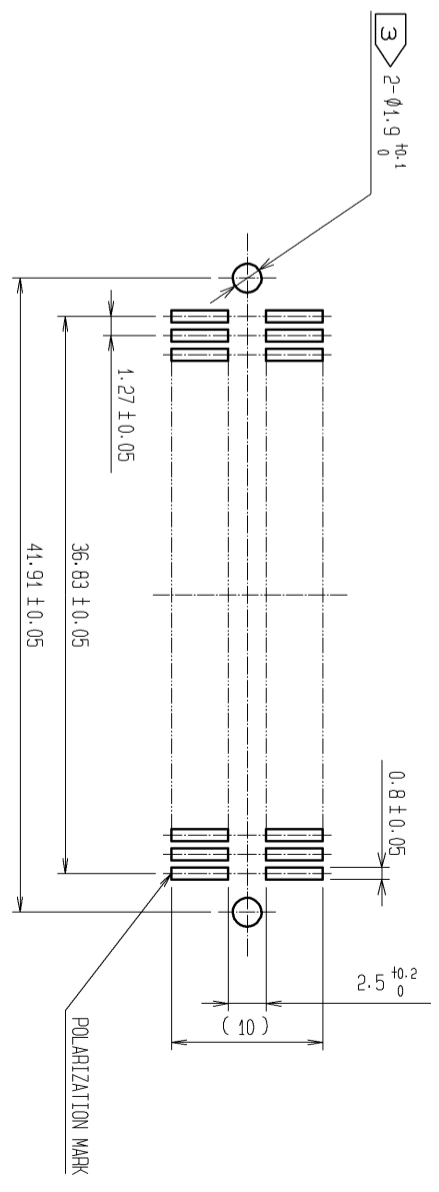
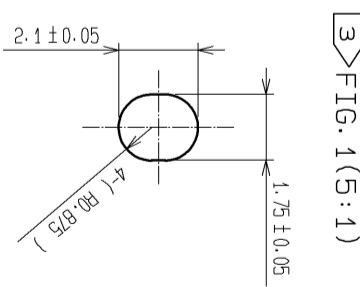
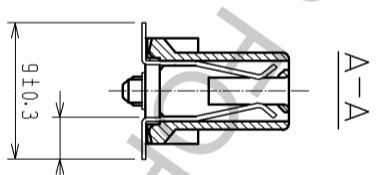
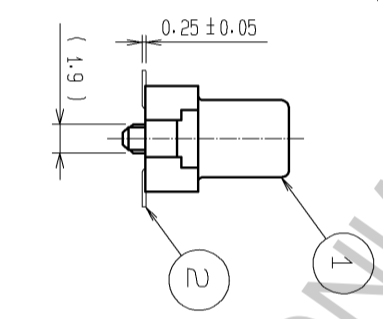
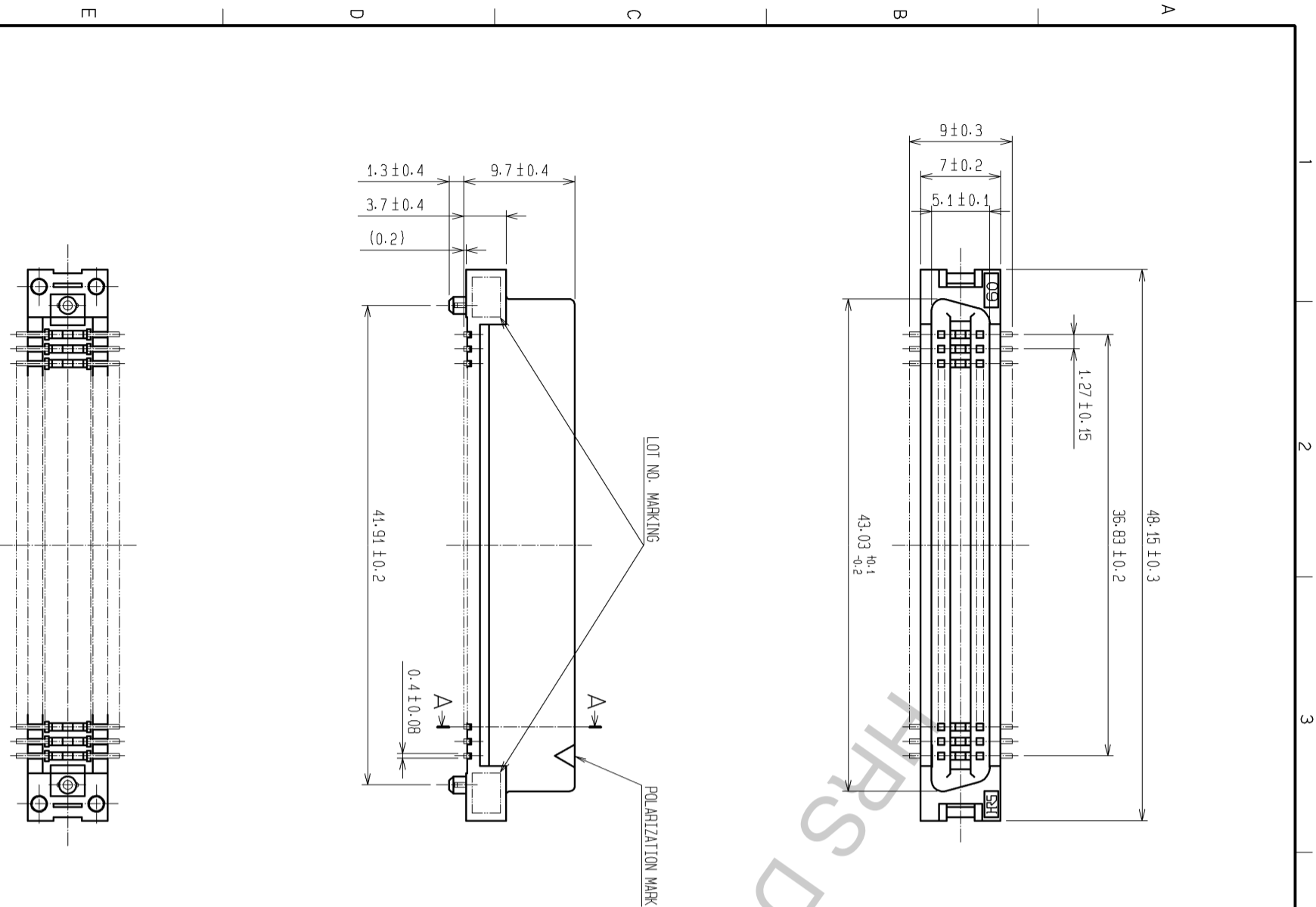

RECOMMENDED LAND PATTERN DIMENSION OF PCB (MOUNTING SIDE)  
 (RECOMMENDED METAL MASK THICKNESS: t=0.2)

FIG. 1 (5:1)

- NOTES
- 1 LEAD CO-PLANARITY SHALL BE 0.15 MAX.
  - 2 THE DIMENSIONS IN PARENTHESES ARE FOR REFERENCE.
  - 3 IN CASE OF THE AUTOMATED MOUNTING, RECOMMENDED HOLE DIAMETER OF BOSS IS SHOWN IN FIG. 1.

1	PPS	LIGHT BROWN	UL94V-0	2	PHOSPHOR BRONZE	CONTACT AREA: GOLD 0.24mm min. LEAD AREA: TIN-PLATING 24mm min. UNDER PLATING: NICKEL 1.54mm min.	
NO.	MATERIAL	FINISH	REMARKS	NO.	MATERIAL	FINISH	REMARKS
UNITS	SCALE	COUNT	DESCRIPTION OF REVISIONS	DESIGNED	CHECKED	DATE	
mm	2:1						
APPROVED: HS. OKAWA		08.05.23		DRAWING		EDC3-082418-21	
CHECKED: HS. OZAWA		08.05.23		PART		FX2-60S-1.27SV(71)	
DESIGNED: KY. NAKAMURA		08.05.23		CODE		CL572-2105-4-71	
DRAWN: TP. MATSUMOTO		08.05.22		NO.			