



Chipsmall Limited consists of a professional team with an average of over 10 year of expertise in the distribution of electronic components. Based in Hongkong, we have already established firm and mutual-benefit business relationships with customers from,Europe,America and south Asia,supplying obsolete and hard-to-find components to meet their specific needs.

With the principle of “Quality Parts,Customers Priority,Honest Operation,and Considerate Service”,our business mainly focus on the distribution of electronic components. Line cards we deal with include Microchip,ALPS,ROHM,Xilinx,Pulse,ON,Everlight and Freescale. Main products comprise IC,Modules,Potentiometer,IC Socket,Relay,Connector.Our parts cover such applications as commercial,industrial, and automotives areas.

We are looking forward to setting up business relationship with you and hope to provide you with the best service and solution. Let us make a better world for our industry!



Contact us

Tel: +86-755-8981 8866 Fax: +86-755-8427 6832

Email & Skype: info@chipsmall.com Web: www.chipsmall.com

Address: A1208, Overseas Decoration Building, #122 Zhenhua RD., Futian, Shenzhen, China





Is Now Part of



ON Semiconductor®

To learn more about ON Semiconductor, please visit our website at
www.onsemi.com

ON Semiconductor and the ON Semiconductor logo are trademarks of Semiconductor Components Industries, LLC dba ON Semiconductor or its subsidiaries in the United States and/or other countries. ON Semiconductor owns the rights to a number of patents, trademarks, copyrights, trade secrets, and other intellectual property. A listing of ON Semiconductor's product/patent coverage may be accessed at www.onsemi.com/site/pdf/Patent-Marking.pdf. ON Semiconductor reserves the right to make changes without further notice to any products herein. ON Semiconductor makes no warranty, representation or guarantee regarding the suitability of its products for any particular purpose, nor does ON Semiconductor assume any liability arising out of the application or use of any product or circuit, and specifically disclaims any and all liability, including without limitation special, consequential or incidental damages. Buyer is responsible for its products and applications using ON Semiconductor products, including compliance with all laws, regulations and safety requirements or standards, regardless of any support or applications information provided by ON Semiconductor. "Typical" parameters which may be provided in ON Semiconductor data sheets and/or specifications can and do vary in different applications and actual performance may vary over time. All operating parameters, including "Typicals" must be validated for each customer application by customer's technical experts. ON Semiconductor does not convey any license under its patent rights nor the rights of others. ON Semiconductor products are not designed, intended, or authorized for use as a critical component in life support systems or any FDA Class 3 medical devices or medical devices with a same or similar classification in a foreign jurisdiction or any devices intended for implantation in the human body. Should Buyer purchase or use ON Semiconductor products for any such unintended or unauthorized application, Buyer shall indemnify and hold ON Semiconductor and its officers, employees, subsidiaries, affiliates, and distributors harmless against all claims, costs, damages, and expenses, and reasonable attorney fees arising out of, directly or indirectly, any claim of personal injury or death associated with such unintended or unauthorized use, even if such claim alleges that ON Semiconductor was negligent regarding the design or manufacture of the part. ON Semiconductor is an Equal Opportunity/Affirmative Action Employer. This literature is subject to all applicable copyright laws and is not for resale in any manner.



FXLA0104

Low-Voltage Dual-Supply 4-Bit Voltage Translator with Configurable Voltage Supplies and Signal Levels, 3-State Outputs, and Auto Direction Sensing

Features

- Bi-Directional Interface between Two Levels: from 1.1 V to 3.6 V
- Fully Configurable: Inputs and Outputs Track V_{CC}
- Non-Preferential Power-Up; Either V_{CC} May Be Powered Up First
- Outputs Switch to 3-State if Either V_{CC} is at GND
- Power-Off Protection
- Bus-Hold on Data Inputs Eliminates the Need for Pull-Up Resistors; Do Not Use Pull-Up Resistors on A or B Ports
- Control Input (OE) Referenced to V_{CCA} Voltage
- Available in the 12-Lead, 1.7 mm x 2.0 mm UMLP Package
- Direction Control Not Necessary
- 100 Mbps Throughput when Translating Between 1.8 V and 2.5 V
- ESD Protection Exceeds:
 - 6 kV HBM (per JESD22-A114 & Mil Std 883e 3015.7)
 - 2 kV CDM (per ESD STM 5.3)

Description

The FXLA0104 is a configurable dual-voltage supply translator for both uni-directional and bi-directional voltage translation between two logic levels. The device allows translation between voltages as high as 3.6 V to as low as 1.1 V. The A port tracks the V_{CCA} level and the B port tracks the V_{CCB} level. This allows for bi-directional voltage translation over a variety of voltage levels: 1.2 V, 1.5 V, 1.8 V, 2.5 V, and 3.3 V.

The device remains in three-state as long as either $V_{CC}=0V$, allowing either V_{CC} to be powered up first. Internal power-down control circuits place the device in 3-state if either V_{CC} is removed.

The OE input, when LOW, disables both the A and B ports by placing them in a 3-state condition. The OE input is supplied by V_{CCA} .

The FXLA0104 supports bi-directional translation without the need for a direction control pin. The two ports of the device have auto-direction sense capability. Either port may sense an input signal and transfer it as an output signal to the other port.

Applications

- Cell Phone, PDA, Digital Camera, Portable GPS

Ordering Information

Part Number	Operating Temperature Range	Top Mark	Package	Packing Method
FXLA0104QFX	-40 to 85°C	XU	12-Lead, 1.7 mm x 2.0 mm Ultrathin Molded Leadless Package (UMLP)	5000 Units Tape and Reel

Pin Configuration

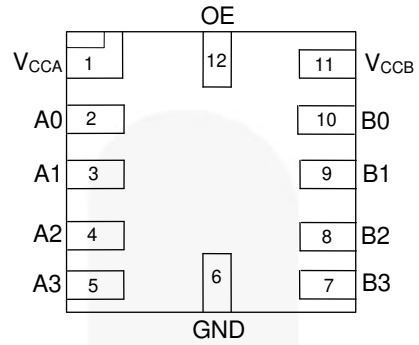

Figure 1. Top Through View

Pin Definitions

Pin #	Name	Description
1	V _{CCA}	A-Side Power Supply
2	A0	A-Side Inputs or 3-State Outputs
3	A1	A-Side Inputs or 3-State Outputs
4	A2	A-Side Inputs or 3-State Outputs
5	A3	A-Side Inputs or 3-State Outputs
6	GND	Ground
7	B3	B-Side Inputs or 3-State Outputs
8	B2	B-Side Inputs or 3-State Outputs
9	B1	B-Side Inputs or 3-State Outputs
10	B0	B-Side Inputs or 3-State Outputs
11	V _{CCB}	B-Side Power Supply
12	OE	Output Enable Input

Functional Diagram

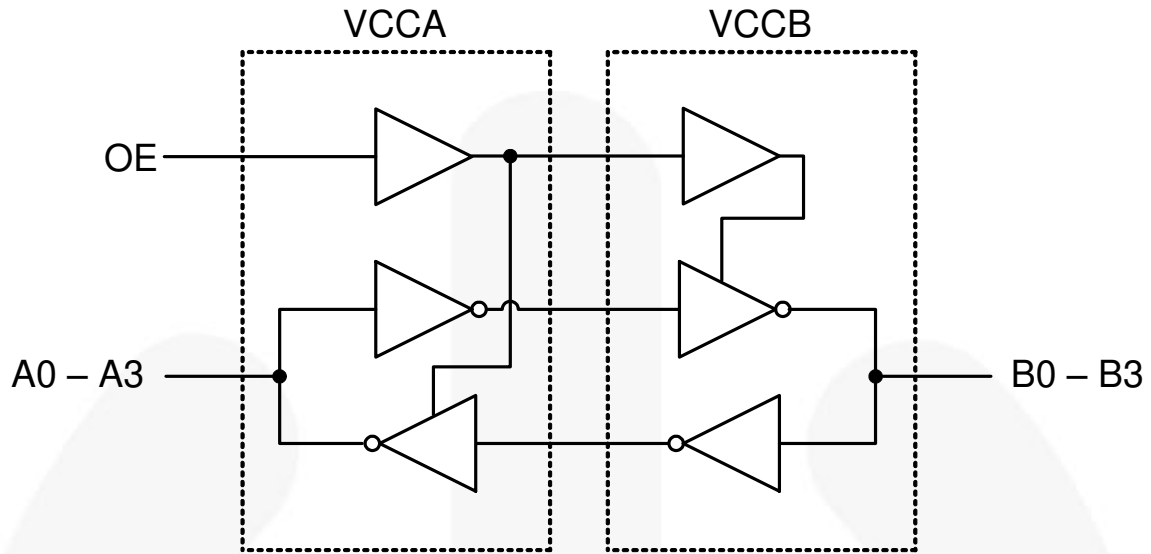

Figure 2. Functional Diagram

Function Table

Control	Outputs
OE	
LOW Logic Level	3-State
HIGH Logic Level	Normal Operation

Absolute Maximum Ratings

Stresses exceeding the absolute maximum ratings may damage the device. The device may not function or be operable above the recommended operating conditions and stressing the parts to these levels is not recommended. In addition, extended exposure to stresses above the recommended operating conditions may affect device reliability. The absolute maximum ratings are stress ratings only.

Symbol	Parameter	Condition	Min.	Max.	Unit
V _{CC}	Supply Voltage	V _{CCA}	-0.5	4.6	V
		V _{CCB}	-0.5	4.6	
V _I	DC Input Voltage	I/O Ports A and B	-0.5	4.6	V
		Control Input (OE)	-0.5	4.6	
V _O	Output Voltage ⁽²⁾	Output 3-State	-0.5	4.6	V
		Output Active (A _n)	-0.5	V _{CCA} +0.5	
		Output Active (B _n)	-0.5	V _{CCB} +0.5	
I _{IK}	DC Input Diode Current	V _{IN} < 0V		-50	mA
I _{OK}	DC Output Diode Current	V _O < 0V		-50	mA
		V _O > V _{CC}		+50	
I _{OH} /I _{OL}	DC Output Source/Sink Current		-50	+50	mA
I _{CC}	DC V _{CC} or Ground Current (per Supply Pin)			±100	mA
T _{STG}	Storage Temperature Range		-65	+150	°C
P _D	Power Dissipation			17	mW
ESD	Electrostatic Discharge Capability	Human Body Model (per JESD22-A114 & Mil Std 883e 3015.7)		6	kV
		Charged Device Model (per ESD STM 5.3)		2	

Notes:

- I_O absolute maximum ratings must be observed.
- All unused inputs and input/outputs must be held at V_{CCi} or GND.

Recommended Operating Conditions

The Recommended Operating Conditions table defines the conditions for actual device operation. Recommended operating conditions are specified to ensure optimal performance to the datasheet specifications. Fairchild does not recommend exceeding them or designing to Absolute Maximum Ratings.

Symbol	Parameter	Condition	Min.	Max.	Unit
V _{CC}	Power Supply	Operating V _{CCA} or V _{CCB}	1.1	3.6	V
V _{IN}	Input Voltage	Ports A and B	0	3.6	V
		Control Input (OE)	0	V _{CCA}	V
T _A	Operating Temperature, Free Air		-40	+85	°C
dt/dV	Minimum Input Edge Rate	V _{CCA/B} = 1.1 to 3.6 V		10	ns/V
θ _{JA}	Thermal Resistance: Junction-to-Ambient			300	°C/W
θ _{JC}	Thermal Resistance: Junction-to-Case			165	°C/W

Power-Up/Power-Down Sequence

FXL translators offer an advantage in that either V_{CC} may be powered up first. This benefit derives from the chip design. When either V_{CC} is at 0V, outputs are in a high-impedance state. The control input (OE) is designed to track the V_{CCA} supply.

The recommended power-up sequence is:

1. Apply power to the first V_{CC} .
2. Apply power to the second V_{CC} .
3. Drive the OE input HIGH to enable the device.

The recommended power-down sequence is:

1. Drive OE input LOW to disable the device.
2. Remove power from either V_{CC} .
3. Remove power from other V_{CC} .

Pull-Up/Pull-Down Resistors

Do not use pull-up or pull-down resistors. This device has bus-hold circuits: pull-up or pull-down resistors are not recommended because they interfere with the output state. The current through these resistors may exceed the hold drive, $I_{I(HOLD)}$ and/or $I_{I(OD)}$ bus-hold currents, resulting in data transition and/or auto-direction sensing failures. The bus-hold feature eliminates the need for extra resistors.

DC Electrical Characteristics

T_A=-40 to 85°C

Symbol	Parameter	Condition	V _{CCA} (V)	V _{CCB} (V)	Min.	Typ.	Max.	Unit
V _{IHA}	High-Level Input Voltage	Data Inputs A _n Control Pin OE	2.70 to 3.60	1.10 to 3.60	2.00			V
			2.30 to 2.70		1.60			
			1.65 to 2.30		.65xV _{CCA}			
			1.40 to 1.65		.65xV _{CCA}			
			1.10 to 1.40		.90xV _{CCA}			
V _{IHB}	High-Level Input Voltage	Data Inputs B _n	2.70 to 3.60	1.10 to 3.60	2.00			V
			2.30 to 2.70		1.60			
			1.65 to 2.30		.65xV _{CCB}			
			1.40 to 1.65		.65xV _{CCB}			
			1.10 to 1.40		.90xV _{CCB}			
V _{ILA}	Low-Level Input Voltage	Data Inputs A _n Control Pin OE	2.70 to 3.60	1.10 to 3.60			.80	V
			2.30 to 2.70				.70	
			1.65 to 2.30				.35xV _{CCA}	
			1.40 to 1.65				.35xV _{CCA}	
			1.10 to 1.40				.10xV _{CCA}	
V _{ILB}	Low-Level Input Voltage	Data Inputs B _n	2.70 to 3.60	1.10 to 3.60			.80	V
			2.30 to 2.70				.70	
			1.65 to 2.30				.35xV _{CCB}	
			1.40 to 1.65				.35xV _{CCB}	
			1.10 to 1.40				.10xV _{CCB}	
V _{OHA}	High-Level Output Voltage ⁽³⁾	I _{OH} =-4 μA	1.10 to 3.60	1.10 to 3.60	V _{CCA} -.4			V
V _{OHB}		I _{OH} =-4 μA	1.10 to 3.60	1.10 to 3.60	V _{CCB} -.4			
V _{OLA}	Low-Level Output Voltage ⁽³⁾	I _{OL} =4 μA	1.10 to 3.60	1.10 to 3.60			.4	V
V _{OLB}		I _{OL} =4 μA	1.10 to 3.60	1.10 to 3.60			.4	
I _{I(HOLD)}	Bus-Hold Input Minimum Drive Current	V _{IN} =0.8 V	3.00	3.00	75.0			μA
		V _{IN} =2.0 V	3.00	3.00	-75.0			
		V _{IN} =0.7 V	2.30	2.30	45.0			
		V _{IN} =1.6 V	2.30	2.30	-45.0			
		V _{IN} =0.57 V	1.65	1.65	25.0			
		V _{IN} =1.07 V	1.65	1.65	-25.0			
		V _{IN} =0.49 V	1.40	1.40	11.0			
		V _{IN} =0.91 V	1.40	1.40	-11.0			
		V _{IN} =0.11 V	1.10	1.10		4.0		
		V _{IN} =0.99 V	1.10	1.10		-4.0		

Note:

3. This is the output voltage for static conditions. Dynamic drive specifications are given in the Dynamic Output Electrical Characteristics table.

Continued on following page...

DC Electrical Characteristics (Continued)

T_A = -40 to 85°C.

Symbol	Parameter	Condition	V _{CCA} (V)	V _{CCB} (V)	Min.	Max.	Unit
I _{I(ODH)}	Bus-Hold Input Overdrive High Current ⁽⁴⁾	Data Inputs A _n , B _n	3.60	3.60	450.0		μA
			2.70	2.70	300.0		
			1.95	1.95	200.0		
			1.60	1.60	120.0		
			1.40	1.40	80.0		
I _{I(ODL)}	Bus-Hold Input Overdrive Low Current ⁽⁵⁾	Data Inputs A _n , B _n	3.60	3.60	-450.0		μA
			2.70	2.70	-300.0		
			1.95	1.95	-200.0		
			1.60	1.60	-120.0		
			1.40	1.40	-80.0		
I _I	Input Leakage Current	Control Inputs OE, V _I =V _{CCA} or GND	1.10 to 3.60	3.60		±1.0	μA
I _{OFF}	Power-Off Leakage Current	A _n V _O =0 V to 3.6 V	0	3.60		±2.0	μA
		B _n V _O =0 V to 3.6 V	3.60	0		±2.0	
I _{OZ}	3-State Output Leakage	A _n , B _n V _O =0 V or 3.6 V, OE=V _{IL}	3.60	3.60		±5.0	μA
		A _n V _O =0 V or 3.6 V, OE=V _{CCA}	3.60	0		±5.0	
		B _n V _O =0 V or 3.6 V, OE=3.6V	0	3.60		±5.0	
I _{CCA/B}	Quiescent Supply Current ^(6, 7)	V _I =V _{CCI} or GND; I _O =0, OE=V _{IH}	1.10 to 3.60	1.10 to 3.60		10.0	μA
I _{CCZ}		V _I =V _{CCI} or GND; I _O =0, OE=GND	1.10 to 3.60	1.10 to 3.60		10.0	μA
I _{CCA}	Quiescent Supply Current	V _I =V _{CCB} or GND; I _O =0 B-to-A Direction; OE=V _{IH}	0	1.10 to 3.60		-10.0	μA
		V _I =V _{CCA} or GND; I _O =0 A-to-B Direction	1.10 to 3.60	0		10.0	
I _{CCB}	Quiescent Supply Current	V _I =V _{CCA} or GND; I _O =0, A-to-B Direction, OE=V _{IH}	1.10 to 3.60	0		-10.0	μA
		V _I =V _{CCB} or GND; I _O =0 B-to-A Direction	0	1.10 to 3.60		10.0	

Notes:

4. An external drive must source at least the specified current to switch LOW-to-HIGH.
5. An external drive must source at least the specified current to switch HIGH-to-LOW.
6. V_{CCI} is the V_{CC} associated with the input side.
7. Reflects current per supply, V_{CCA} or V_{CCB}.

Dynamic Output Electrical Characteristic

A Port (A_n)

Output Load: $C_L=15$ pF, $R_L \geq M\Omega$ ($C_{I/O}=4$ pF), $T_A=-40$ to 85°C

Symbol	Parameter	$V_{CCA}=3.0$ V to 3.6 V		$V_{CCA}=2.3$ V to 2.7 V		$V_{CCA}=1.65$ V to 1.95 V		$V_{CCA}=1.4$ V to 1.6 V		$V_{CCA}=1.1$ V to 1.3 V	Unit
		Typ.	Max.	Typ.	Max.	Typ.	Max.	Typ.	Max.	Typ.	
t_{rise}	Output Rise Time A Port ⁽⁹⁾		3.0		3.5		4.0		5.0	7.5	ns
t_{fall}	Output Fall Time A Port ⁽¹⁰⁾		3.0		3.5		4.0		5.0	7.5	ns
I_{OHD}	Dynamic Output Current High ⁽⁹⁾	-11.4		-7.5		-4.7		-3.2		-1.7	mA
I_{OLD}	Dynamic Output Current Low ⁽¹⁰⁾	+11.4		+7.5		+4.7		+3.2		+1.7	mA

B Port (B_n)

Output Load: $C_L=15$ pF, $R_L \geq M\Omega$ ($C_{I/O}=5$ pF), $T_A=-40$ to 85°C

Symbol	Parameter	$V_{CCB}=3.0$ V to 3.6 V		$V_{CCB}=2.3$ V to 2.7 V		$V_{CCB}=1.65$ V to 1.95 V		$V_{CCB}=1.4$ V to 1.6 V		$V_{CCB}=1.1$ V to 1.3 V	Unit
		Typ.	Max.	Typ.	Max.	Typ.	Max.	Typ.	Max.	Typ.	
t_{rise}	Output Rise Time B Port ⁽⁹⁾		3.0		3.5		4.0		5.0	7.5	ns
t_{fall}	Output Fall Time B Port ⁽¹⁰⁾		3.0		3.5		4.0		5.0	7.5	ns
I_{OHD}	Dynamic Output Current High ⁽⁹⁾	-12.0		-7.9		-5.0		-3.4		-1.8	mA
I_{OLD}	Dynamic Output Current Low ⁽¹⁰⁾	+12.0		+7.9		+5.0		+3.4		+1.8	mA

Notes:

8. Dynamic output characteristics are guaranteed, but not tested.
9. See Figure 7.
10. See Figure 8.

AC Characteristics $V_{CCA} = 3.0\text{ V to }3.6\text{ V}$, $T_A = -40\text{ to }85^\circ\text{C}$

Symbol	Parameter	$V_{CCB}=3.0\text{ V to }3.6\text{ V}$		$V_{CCB}=2.3\text{ V to }2.7\text{ V}$		$V_{CCB}=1.65\text{ V to }1.95\text{ V}$		$V_{CCB}=1.4\text{ V to }1.6\text{ V}$		$V_{CCB}=1.1\text{ V to }1.3\text{ V}$	Unit
		Min.	Max.	Min.	Max.	Min.	Max.	Min.	Max.	Typ.	
t_{PLH}, t_{PHL}	A to B	0.2	4.0	0.3	4.2	0.5	5.4	0.6	6.8	6.9	ns
	B to A	0.2	4.0	0.2	4.1	0.3	5.0	0.5	6.0	4.5	ns
t_{PZL}, t_{PZH}	OE to A, OE to B		1.7		1.7		1.7		1.7	1.7	μs
t_{SKEW}	A Port, B Port ⁽¹¹⁾		0.5		0.5		0.5		1.0	1.0	ns

 $V_{CCA} = 2.3\text{ V to }2.7\text{ V}$, $T_A = -40\text{ to }85^\circ\text{C}$

Symbol	Parameter	$V_{CCB}=3.0\text{ V to }3.6\text{ V}$		$V_{CCB}=2.3\text{ V to }2.7\text{ V}$		$V_{CCB}=1.65\text{ V to }1.95\text{ V}$		$V_{CCB}=1.4\text{ V to }1.6\text{ V}$		$V_{CCB}=1.1\text{ V to }1.3\text{ V}$	Unit
		Min.	Max.	Min.	Max.	Min.	Max.	Min.	Max.	Typ.	
t_{PLH}, t_{PHL}	A to B	0.2	4.1	0.4	4.5	0.5	5.6	0.8	6.9	7.0	ns
	B to A	0.3	4.2	0.4	4.5	0.5	5.5	0.5	6.5	4.8	ns
t_{PZL}, t_{PZH}	OE to A, OE to B		1.7		1.7		1.7		1.7	1.7	μs
t_{SKEW}	A Port, B Port ⁽¹¹⁾		0.5		0.5		0.5		1.0	1.0	ns

 $V_{CCA} = 1.65\text{ V to }1.95\text{ V}$, $T_A = -40\text{ to }85^\circ\text{C}$

Symbol	Parameter	$V_{CCB}=3.0\text{ V to }3.6\text{ V}$		$V_{CCB}=2.3\text{ V to }2.7\text{ V}$		$V_{CCB}=1.65\text{ V to }1.95\text{ V}$		$V_{CCB}=1.4\text{ V to }1.6\text{ V}$		$V_{CCB}=1.1\text{ V to }1.3\text{ V}$	Unit
		Min.	Max.	Min.	Max.	Min.	Max.	Min.	Max.	Typ.	
t_{PLH}, t_{PHL}	A to B	0.3	5.0	0.5	5.5	0.8	6.7	0.9	7.5	7.5	ns
	B to A	0.5	5.4	0.5	5.6	0.8	6.7	1.0	7.0	5.4	ns
t_{PZL}, t_{PZH}	OE to A, OE to B		1.7		1.7		1.7		1.7	1.7	μs
t_{SKEW}	A Port, B Port ⁽¹¹⁾		0.5		0.5		0.5		1.0	1.0	ns

Note:

11. Skew is the variation of propagation delay between output signals and applies only to output signals on the same port (A_n or B_n) and switching with the same polarity (LOW-to-HIGH or HIGH-to-LOW) (see Figure 10). Skew is guaranteed, but not tested.

AC Characteristics (Continued) $V_{CCA} = 1.4 \text{ V to } 1.6 \text{ V}$, $T_A = -40 \text{ to } 85^\circ\text{C}$

Symbol	Parameter	$V_{CCB}=3.0 \text{ V to } 3.6 \text{ V}$		$V_{CCB}=2.3 \text{ V to } 2.7 \text{ V}$		$V_{CCB}=1.65 \text{ V to } 1.95 \text{ V}$		$V_{CCB}=1.4 \text{ V to } 1.6 \text{ V}$		$V_{CCB}=1.1 \text{ V to } 1.3 \text{ V}$	Unit
		Min.	Max.	Min.	Max.	Min.	Max.	Min.	Max.	Typ.	
t_{PLH}, t_{PHL}	A to B	0.5	6.0	0.5	6.5	1.0	7.0	1.0	8.5	7.9	ns
	B to A	0.6	6.8	0.8	6.9	0.9	7.5	1.0	8.5	6.1	ns
t_{PZL}, t_{PZH}	OE to A, OE to B		1.7		1.7		1.7		1.7	1.7	μs
t_{SKEW}	A Port, B Port ⁽¹²⁾		1.0		1.0		1.0		1.0	1.0	ns

 $V_{CCA} = 1.1 \text{ V to } 1.3 \text{ V}$, $T_A = -40 \text{ to } 85^\circ\text{C}$

Symbol	Parameter	$V_{CCB}=3.0 \text{ V to } 3.6 \text{ V}$	$V_{CCB}=2.3 \text{ V to } 2.7 \text{ V}$	$V_{CCB}=1.65 \text{ V to } 1.95 \text{ V}$	$V_{CCB}=1.4 \text{ V to } 1.6 \text{ V}$	$V_{CCB}=1.1 \text{ V to } 1.3 \text{ V}$	Unit
		Typ.	Typ.	Typ.	Typ.	Typ.	
t_{PLH}, t_{PHL}	A to B	4.6	4.8	5.4	6.2	9.2	ns
	B to A	6.8	7.0	7.4	7.8	9.1	ns
t_{PZL}, t_{PZH}	OE to A, OE to B	1.7	1.7	1.7	1.7	1.7	μs
t_{SKEW}	A Port, B Port ⁽¹²⁾	1.0	1.0	1.0	1.0	1.0	ns

Note:

12. Skew is the variation of propagation delay between output signals and applies only to output signals on the same port (A_n or B_n) and switching with the same polarity (LOW-to-HIGH or HIGH-to-LOW) (see Figure 10). Skew is guaranteed, but not tested.

Maximum Data Rate^(13, 14)

T_A=-40 to 85°C

V _{CCA}	V _{CCB} =3.0 V to 3.6 V	V _{CCB} =2.3V to 2.7V	V _{CCB} =1.65V to 1.95V	V _{CCB} =1.4V to 1.6V	V _{CCB} =1.1V to 1.3V	Unit
	Min.	Min.	Min.	Min.	Typ.	
V _{CCA} =3.00 to 3.60 V	140	120	100	80	40	Mbps
V _{CCA} =2.30 to 2.70 V	120	120	100	80	40	Mbps
V _{CCA} =1.65 to 1.95 V	100	100	80	60	40	Mbps
V _{CCA} =1.40 to 1.60 V	80	80	60	60	40	Mbps
V _{CCA} =1.10 to 1.30 V	Typ.	Typ.	Typ.	Typ.	Typ.	
	40	40	40	40	40	Mbps

Notes:

- 13. Maximum data rate is guaranteed, but not tested.
- 14. Maximum data rate is specified in megabits per second (see Figure 9). It is equivalent to two times the F-toggle frequency, specified in megahertz. For example, 100 Mbps is equivalent to 50MHz.

Capacitance

Symbol	Parameter	Conditions	T _A =+25°C Typical	Unit	
C _{IN}	Input Capacitance Control Pin (OE)	V _{CCA} =V _{CCB} =GND	3	pF	
C _{I/O}	Input/Output Capacitance	V _{CCA} =V _{CCB} =3.3 V, OE=GND	A _n	4	pF
			B _n	5	
C _{pd}	Power Dissipation Capacitance	V _{CCA} =V _{CCB} =3.3 V, V _I =0V or V _{CC} , f=10 MHz	25	pF	

I/O Architecture Benefit

The FXLA0104 I/O architecture benefits the end user, beyond level translation, in the following three ways:

Auto Direction without an external direction pin.

Drive Capacitive Loads. Automatically shifts to a higher current drive mode only during “Dynamic Mode” or HL / LH transitions.

Lower Power Consumption. Automatically shifts to low-power mode during “Static Mode” (no transitions), lowering power consumption.

The FXLA0104 does not require a direction pin. Instead, the I/O architecture detects input transitions on both side and automatically transfers the data to the corresponding output. For example, for a given channel, if both A and B side are at a static LOW, the direction has been established as $A \rightarrow B$, and a LH transition occurs on the B port; the FXLA0104 internal I/O architecture automatically changes direction from $A \rightarrow B$ to $B \rightarrow A$.

During HL / LH transitions, or “Dynamic Mode,” a strong output driver drives the output channel in parallel with a weak output driver. After a typical delay of approximately 10 ns – 50 ns, the strong driver is turned off, leaving the weak driver enabled for holding the logic state of the channel. This weak driver is called the “bus

hold.” “Static Mode” is when only the bus hold drives the channel. The bus hold can be overridden in the event of a direction change. The strong driver allows the FXLA0104 to quickly charge and discharge capacitive transmission lines during dynamic mode. Static mode conserves power, where I_{CC} is typically $< 5 \mu A$.

Bus Hold Minimum Drive Current

Specifies the minimum amount of current the bus hold driver can source/sink. The bus hold minimum drive current (I_{HOLD}) is V_{CC} dependent and guaranteed in the DC Electrical tables. The intent is to maintain a valid output state in a static mode, but that can be overridden when an input data transition occurs.

Bus Hold Input Overdrive Drive Current

Specifies the minimum amount of current required (by an external device) to overdrive the bus hold in the event of a direction change. The bus hold overdrive (I_{ODH} , I_{ODL}) is V_{CC} dependent and guaranteed in the DC Electrical tables.

Dynamic Output Current

The strength of the output driver during LH / HL transitions is *referenced on page 8, Dynamic Output Electrical Characteristics, I_{OHD} , and I_{OLD} .*

Test Diagrams

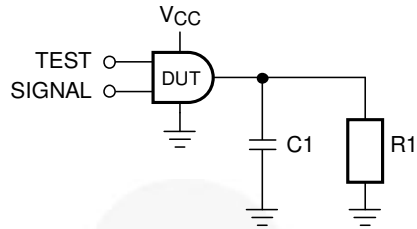

Figure 3. Test Circuit

Table 1. AC Test Conditions

Test	Input Signal	Output Enable Control
t_{PLH} , t_{PHL}	Data Pulses	VCCA
t_{PZL}	0V	LOW to HIGH Switch
t_{PZH}	VCCI	LOW to HIGH Switch

Table 2. AC Load

V _{CCO}	C1	R1
1.2 V ± 0.1 V	15 pF	1 MΩ
1.5 V ± 0.1 V	15 pF	1 MΩ
1.8 V ± 0.15 V	15 pF	1 MΩ
2.5 V ± 0.2 V	15 pF	1 MΩ
3.3 V ± 0.3 V	15 pF	1 MΩ

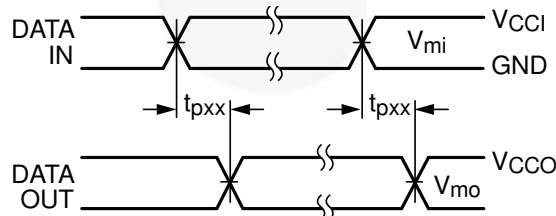

Figure 4. Waveform for Inverting and Non-Inverting Functions

Notes:

- 15. Input $t_R = t_F = 2.0$ ns, 10% to 90%.
- 16. Input $t_R = t_F = 2.5$ ns, 10% to 90%, at $V_I = 3.0$ V to 3.6 V only.

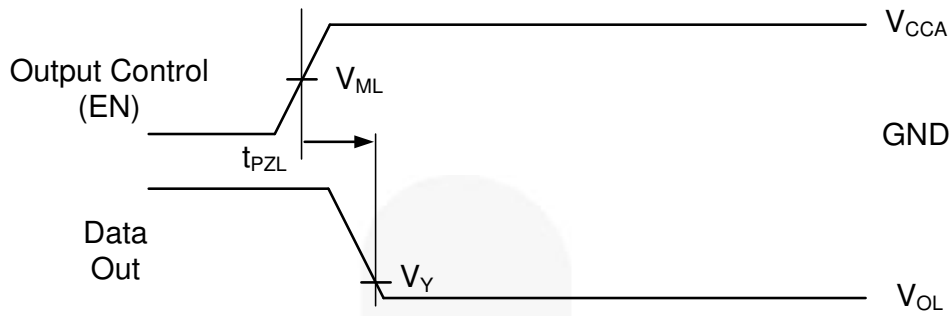

Figure 5. 3-State Output Low Enable

Notes:

- 17. Input $t_R = t_F = 2.0$ ns, 10% to 90%.
- 18. Input $t_R = t_F = 2.5$ ns, 10% to 90%, at $V_I = 3.0$ V to 3.6 V only.

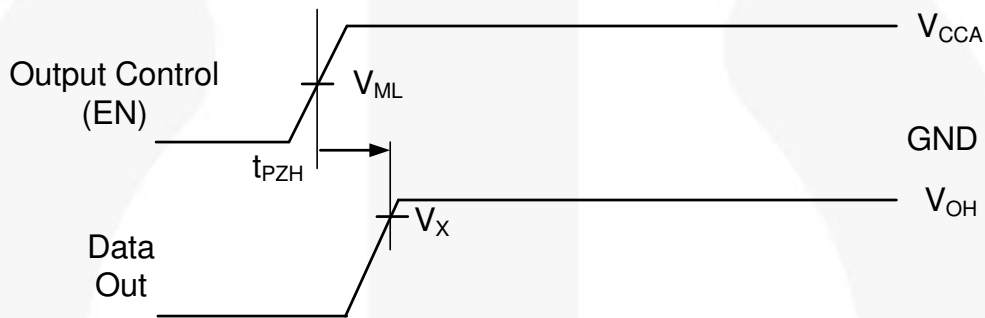

Figure 6. 3-State Output High Enable

Notes:

- 19. Input $t_R = t_F = 2.0$ ns, 10% to 90%.
- 20. Input $t_R = t_F = 2.5$ ns, 10% to 90%, at $V_I = 3.0$ V to 3.6 V only.

Table 3. Test Measure Points

Symbol	V_{DD}
$V_{MI}^{(21)}$	$V_{CCI} / 2$
V_{MO}	$V_{CC0} / 2$
V_X	$0.9 \times V_{CC0}$
V_Y	$0.1 \times V_{CC0}$

Note:

- 21. $V_{CCI} = V_{CCA}$ for control pin OE or $V_{MI}(V_{CCA}/2)$.

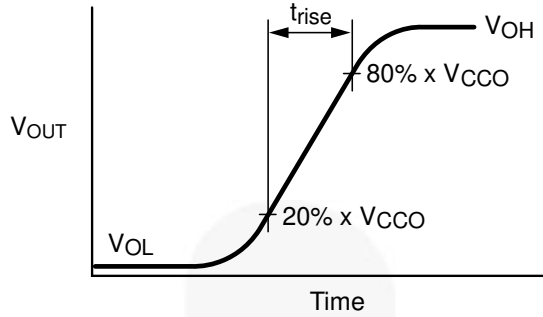

$$I_{OHD} \approx (C_L + C_{I/O}) \times \frac{\Delta V_{OUT}}{\Delta t} = (C_L + C_{I/O}) \times \frac{(20\% - 80\%) \cdot V_{CCO}}{t_{RISE}}$$

Figure 7. Active Output Rise Time and Dynamic Output Current High

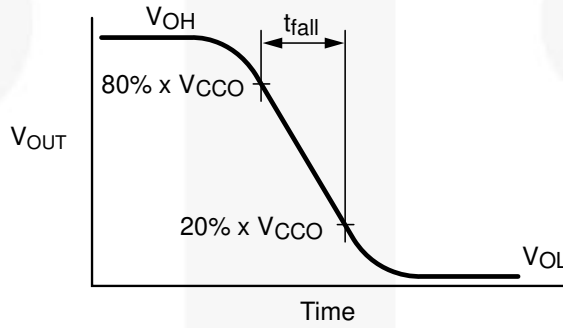

$$I_{OLD} \approx (C_L + C_{I/O}) \times \frac{\Delta V_{OUT}}{\Delta t} = (C_L + C_{I/O}) \times \frac{(80\% - 20\%) \cdot V_{CCO}}{t_{FALL}}$$

Figure 8. Active Output Fall Time and Dynamic Output Current Low

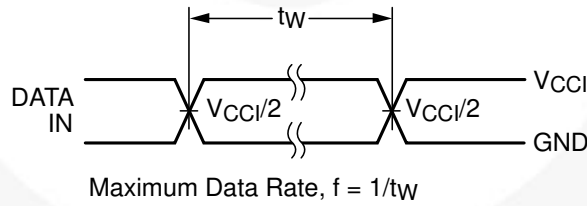

Figure 9. Maximum Data Rate

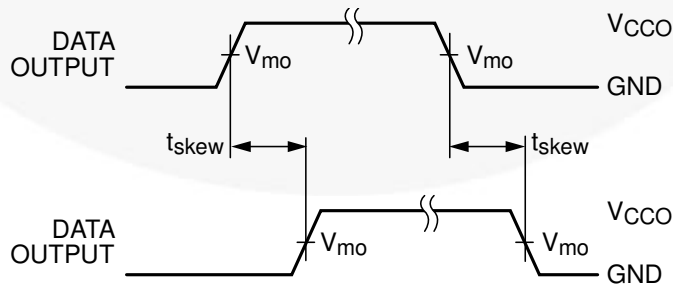

Figure 10. Output Skew Time

Note:

22. $t_{SKEW} = (t_{pHLmax} - t_{pHLmin})$ OR $(t_{pLHmax} - t_{pLHmin})$

ON Semiconductor and  are trademarks of Semiconductor Components Industries, LLC dba ON Semiconductor or its subsidiaries in the United States and/or other countries. ON Semiconductor owns the rights to a number of patents, trademarks, copyrights, trade secrets, and other intellectual property. A listing of ON Semiconductor's product/patent coverage may be accessed at www.onsemi.com/site/pdf/Patent-Marking.pdf. ON Semiconductor reserves the right to make changes without further notice to any products herein. ON Semiconductor makes no warranty, representation or guarantee regarding the suitability of its products for any particular purpose, nor does ON Semiconductor assume any liability arising out of the application or use of any product or circuit, and specifically disclaims any and all liability, including without limitation special, consequential or incidental damages. Buyer is responsible for its products and applications using ON Semiconductor products, including compliance with all laws, regulations and safety requirements or standards, regardless of any support or applications information provided by ON Semiconductor. "Typical" parameters which may be provided in ON Semiconductor data sheets and/or specifications can and do vary in different applications and actual performance may vary over time. All operating parameters, including "Typicals" must be validated for each customer application by customer's technical experts. ON Semiconductor does not convey any license under its patent rights nor the rights of others. ON Semiconductor products are not designed, intended, or authorized for use as a critical component in life support systems or any FDA Class 3 medical devices or medical devices with a same or similar classification in a foreign jurisdiction or any devices intended for implantation in the human body. Should Buyer purchase or use ON Semiconductor products for any such unintended or unauthorized application, Buyer shall indemnify and hold ON Semiconductor and its officers, employees, subsidiaries, affiliates, and distributors harmless against all claims, costs, damages, and expenses, and reasonable attorney fees arising out of, directly or indirectly, any claim of personal injury or death associated with such unintended or unauthorized use, even if such claim alleges that ON Semiconductor was negligent regarding the design or manufacture of the part. ON Semiconductor is an Equal Opportunity/Affirmative Action Employer. This literature is subject to all applicable copyright laws and is not for resale in any manner.

PUBLICATION ORDERING INFORMATION

LITERATURE FULFILLMENT:

Literature Distribution Center for ON Semiconductor
19521 E. 32nd Pkwy, Aurora, Colorado 80011 USA
Phone: 303-675-2175 or 800-344-3860 Toll Free USA/Canada
Fax: 303-675-2176 or 800-344-3867 Toll Free USA/Canada
Email: orderlit@onsemi.com

N. American Technical Support: 800-282-9855 Toll Free
USA/Canada
Europe, Middle East and Africa Technical Support:
Phone: 421 33 790 2910
Japan Customer Focus Center
Phone: 81-3-5817-1050

ON Semiconductor Website: www.onsemi.com
Order Literature: <http://www.onsemi.com/orderlit>
For additional information, please contact your local
Sales Representative