



Chipsmall Limited consists of a professional team with an average of over 10 year of expertise in the distribution of electronic components. Based in Hongkong, we have already established firm and mutual-benefit business relationships with customers from,Europe,America and south Asia,supplying obsolete and hard-to-find components to meet their specific needs.

With the principle of “Quality Parts,Customers Priority,Honest Operation,and Considerate Service”,our business mainly focus on the distribution of electronic components. Line cards we deal with include Microchip,ALPS,ROHM,Xilinx,Pulse,ON,Everlight and Freescale. Main products comprise IC,Modules,Potentiometer,IC Socket,Relay,Connector.Our parts cover such applications as commercial,industrial, and automotives areas.

We are looking forward to setting up business relationship with you and hope to provide you with the best service and solution. Let us make a better world for our industry!



## Contact us

Tel: +86-755-8981 8866 Fax: +86-755-8427 6832

Email & Skype: info@chipsmall.com Web: www.chipsmall.com

Address: A1208, Overseas Decoration Building, #122 Zhenhua RD., Futian, Shenzhen, China





Is Now Part of



**ON Semiconductor®**

To learn more about ON Semiconductor, please visit our website at  
[www.onsemi.com](http://www.onsemi.com)

ON Semiconductor and the ON Semiconductor logo are trademarks of Semiconductor Components Industries, LLC dba ON Semiconductor or its subsidiaries in the United States and/or other countries. ON Semiconductor owns the rights to a number of patents, trademarks, copyrights, trade secrets, and other intellectual property. A listing of ON Semiconductor's product/patent coverage may be accessed at [www.onsemi.com/site/pdf/Patent-Marking.pdf](http://www.onsemi.com/site/pdf/Patent-Marking.pdf). ON Semiconductor reserves the right to make changes without further notice to any products herein. ON Semiconductor makes no warranty, representation or guarantee regarding the suitability of its products for any particular purpose, nor does ON Semiconductor assume any liability arising out of the application or use of any product or circuit, and specifically disclaims any and all liability, including without limitation special, consequential or incidental damages. Buyer is responsible for its products and applications using ON Semiconductor products, including compliance with all laws, regulations and safety requirements or standards, regardless of any support or applications information provided by ON Semiconductor. "Typical" parameters which may be provided in ON Semiconductor data sheets and/or specifications can and do vary in different applications and actual performance may vary over time. All operating parameters, including "Typicals" must be validated for each customer application by customer's technical experts. ON Semiconductor does not convey any license under its patent rights nor the rights of others. ON Semiconductor products are not designed, intended, or authorized for use as a critical component in life support systems or any FDA Class 3 medical devices or medical devices with a same or similar classification in a foreign jurisdiction or any devices intended for implantation in the human body. Should Buyer purchase or use ON Semiconductor products for any such unintended or unauthorized application, Buyer shall indemnify and hold ON Semiconductor and its officers, employees, subsidiaries, affiliates, and distributors harmless against all claims, costs, damages, and expenses, and reasonable attorney fees arising out of, directly or indirectly, any claim of personal injury or death associated with such unintended or unauthorized use, even if such claim alleges that ON Semiconductor was negligent regarding the design or manufacture of the part. ON Semiconductor is an Equal Opportunity/Affirmative Action Employer. This literature is subject to all applicable copyright laws and is not for resale in any manner.



# FXMAR2102 Dual-Supply, 2-Bit Voltage Translator / Isolator for I<sup>2</sup>C Applications

## Features

- Bi-Directional Interface between Any Two Levels: 1.65 V to 5.5 V
- No Direction Control Needed
- Internal 10 K $\Omega$  Pull-Up Resistors
- System GPIO Resources Not Required when OE Tied to V<sub>CCA</sub>
- I<sup>2</sup>C-Bus<sup>®</sup> Isolation
- A/B Port V<sub>OL</sub> = 175 mV (Typical), V<sub>IL</sub> = 150 mV, I<sub>OL</sub> = 6 mA
- Open-Drain Inputs / Outputs
- Works in Push Pull Environment
- Accommodates Standard-Mode and Fast-Mode I<sup>2</sup>C-Bus Devices
- Supports I<sup>2</sup>C Clock Stretching & Multi-Master
- Fully Configurable: Inputs and Outputs Track V<sub>CC</sub>
- Non-Preferential Power-Up; Either V<sub>CC</sub> Can Power-Up First
- Outputs Switch to 3-State if Either V<sub>CC</sub> is at GND
- Tolerant Output Enable: 5 V
- Packaged in 8-Terminal Leadless MicroPak™ (1.6 mm x 1.6 mm) and Ultrathin MLP (1.2 mm x 1.4 mm)
- ESD Protection Exceeds:
  - B Port: 8 kV HBM ESD (vs. GND & vs. V<sub>CCB</sub>)
  - All Pins: 4 kV HBM ESD (per JESD22-A114)
  - 2 kV CDM (per JESD22-C101)

## Description

The FXMAR2102 is a high-performance configurable dual-voltage-supply translator for bi-directional voltage translation over a wide range of input and output voltages levels. The FXMAR2102 also works in a push-pull environment.

It is intended for use as a voltage translator between I<sup>2</sup>C-Bus<sup>®</sup> compliant masters and slaves. Internal 10 K $\Omega$  pull-up resistors are provided.

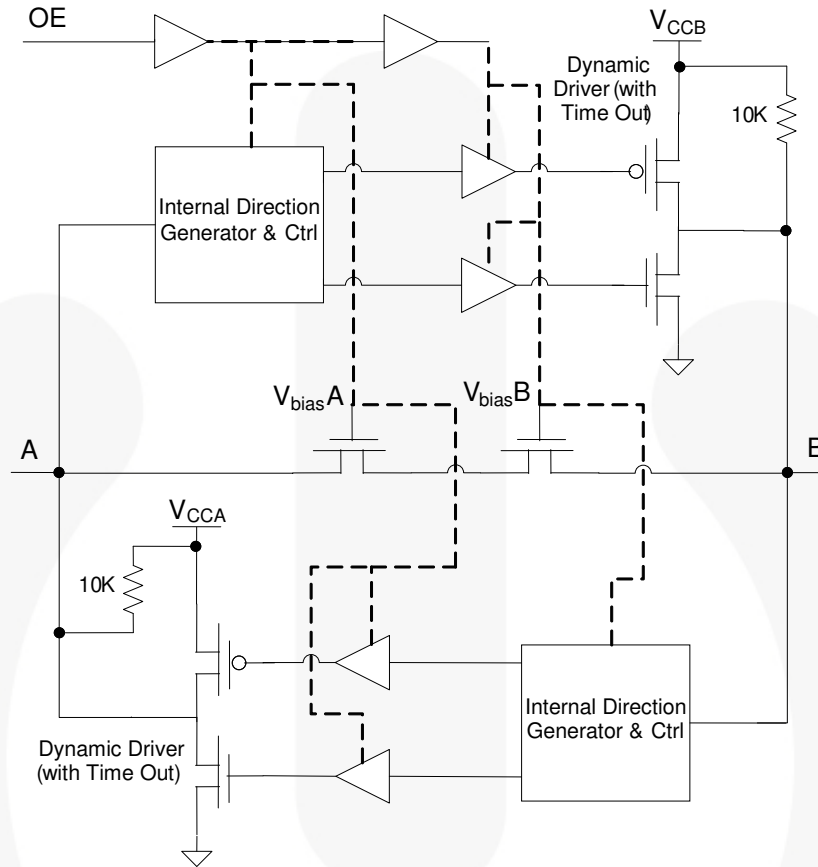
The device is designed so the A port tracks the V<sub>CCA</sub> level and the B port tracks the V<sub>CCB</sub> level. This allows for bi-directional A/B-port voltage translation between any two levels from 1.65 V to 5.5 V. V<sub>CCA</sub> can equal V<sub>CCB</sub> from 1.65 V to 5.5 V. Either V<sub>CC</sub> can be powered-up first. Internal power-down control circuits place the device in 3-state if either V<sub>CC</sub> is removed.

The two ports of the device have automatic direction-sense capability. Either port may sense an input signal and transfer it as an output signal to the other port.

## Ordering Information

Part Number	Operating Temperature Range	Top Mark	Package	Packing Method
FXMAR2102L8X	-40 to +85°C	BU	8-Lead MicroPak™, 1.6 mm Wide	5000 Units on Tape and Reel
FXMAR2102UMX			8-Lead Ultrathin MLP, 1.2 mm x 1.4 mm	

**Block Diagram**



**Figure 1. Block Diagram, 1 of 2 Channels**



## Pin Configuration

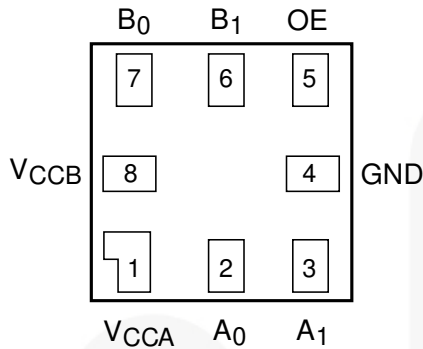


Figure 2. MicroPak™ (Top-Through View)

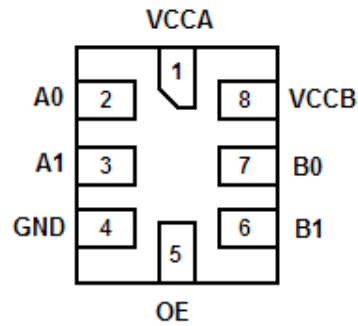


Figure 3. UMLP (Top-Through View)

## Pin Definitions

Pin #	Name	Description
1	V <sub>CCA</sub>	A-Side Power Supply
2, 3	A <sub>0</sub> , A <sub>1</sub>	A-Side Inputs or 3-State Outputs
4	GND	Ground
5	OE	Output Enable Input
6, 7	B <sub>1</sub> , B <sub>0</sub>	B-Side Inputs or 3-State Outputs
8	V <sub>CCB</sub>	B-Side Power Supply

## Truth Table

Control	Outputs
OE <sup>(1)</sup>	
LOW Logic Level	3-State
HIGH Logic Level	Normal Operation

### Note:

1. If the OE pin is driven LOW, the FXMAR2102 is disabled and the A<sub>0</sub>, A<sub>1</sub>, B<sub>0</sub>, and B<sub>1</sub> pins (including dynamic drivers) are forced into 3-state and all four 10 KΩ internal pull-up resistors are decoupled from their respective V<sub>CC</sub>.

## Absolute Maximum Ratings

Stresses exceeding the Absolute Maximum Ratings may damage the device. The device may not function or be operable above the recommended operating conditions and stressing the parts to these levels is not recommended. In addition, extended exposure to stresses above the recommended operating conditions may affect device reliability. The absolute maximum ratings are stress ratings only.

Symbol	Parameter		Min.	Max.	Units
$V_{CCA}, V_{CCB}$	Supply Voltage		-0.5	7.0	V
$V_{IN}$	DC Input Voltage	A Port	-0.5	7.0	
		B Port	-0.5	7.0	
		Control Input (OE)	-0.5	7.0	
$V_O$	Output Voltage <sup>(2)</sup>	$A_n$ Outputs 3-State	-0.5	7.0	V
		$B_n$ Outputs 3-State	-0.5	7.0	
		$A_n$ Outputs Active	-0.5	$V_{CCA} + 0.5V$	
		$B_n$ Outputs Active	-0.5	$V_{CCB} + 0.5V$	
$I_{IK}$	DC Input Diode Current	At $V_{IN} < 0V$		-50	mA
$I_{OK}$	DC Output Diode Current	At $V_O < 0V$		-50	mA
		At $V_O > V_{CC}$		+50	
$I_{OH} / I_{OL}$	DC Output Source/Sink Current		-50	+50	mA
$I_{CC}$	DC $V_{CC}$ or Ground Current per Supply Pin			±100	mA
$P_D$	Power Dissipation	At 400 KHz		0.129	mW
$T_{STG}$	Storage Temperature Range		-65	+150	°C
ESD	Electrostatic Discharge Capability	Human Body Model, B-Port Pins		8	kV
		Human Body Model, All Pins (JESD22-A114)		4	
		Charged Device Mode, JESD22-C101		2	

**Note:**

2.  $I_O$  absolute maximum rating must be observed.

## Recommended Operating Conditions

The Recommended Operating Conditions table defines the conditions for actual device operation. Recommended operating conditions are specified to ensure optimal performance to the datasheet specifications. Fairchild does not recommend exceeding them or designing to Absolute Maximum Ratings.

Symbol	Parameter		Min.	Max.	Units
$V_{CCA}, V_{CCB}$	Power Supply Operating		1.65	5.50	V
$V_{IN}$	Input Voltage <sup>(3)</sup>	A-Port	0	5.5	V
		B-Port	0	5.5	
		Control Input (OE)	0	$V_{CCA}$	
$\Theta_{JA}$	Thermal Resistance	8-Lead MicroPak™		279	C°/W
		8-Lead Ultrathin MLP		302	
$T_A$	Free Air Operating Temperature		-40	+85	°C

**Note:**

3. All unused inputs and I/O pins must be held at  $V_{CCI}$  or GND.  $V_{CCI}$  is the  $V_{CC}$  associated with the input side.

## Functional Description

### Power-Up / Power-Down Sequencing

FXM translators offer an advantage in that either  $V_{CC}$  may be powered up first. This benefit derives from the chip design. When either  $V_{CC}$  is at 0 V, outputs are in a high-impedance state. The control input (OE) is designed to track the  $V_{CCA}$  supply. A pull-down resistor tying OE to GND should be used to ensure that bus contention, excessive currents, or oscillations do not occur during power-up/-down. The size of the pull-down resistor is based upon the current-sinking capability of the device driving the OE pin.

#### The recommended power-up sequence is:

1. Apply power to the first  $V_{CC}$ .
2. Apply power to the second  $V_{CC}$ .
3. Drive the OE input HIGH to enable the device.

#### The recommended power-down sequence is:

1. Drive OE input LOW to disable the device.
2. Remove power from either  $V_{CC}$ .
3. Remove power from the other  $V_{CC}$ .

#### Note:

4. Alternatively, the OE pin can be hardwired to  $V_{CCA}$  to save GPIO pins. If OE is hardwired to  $V_{CCA}$ , either  $V_{CC}$  can be powered up or down first.

### Application Circuit

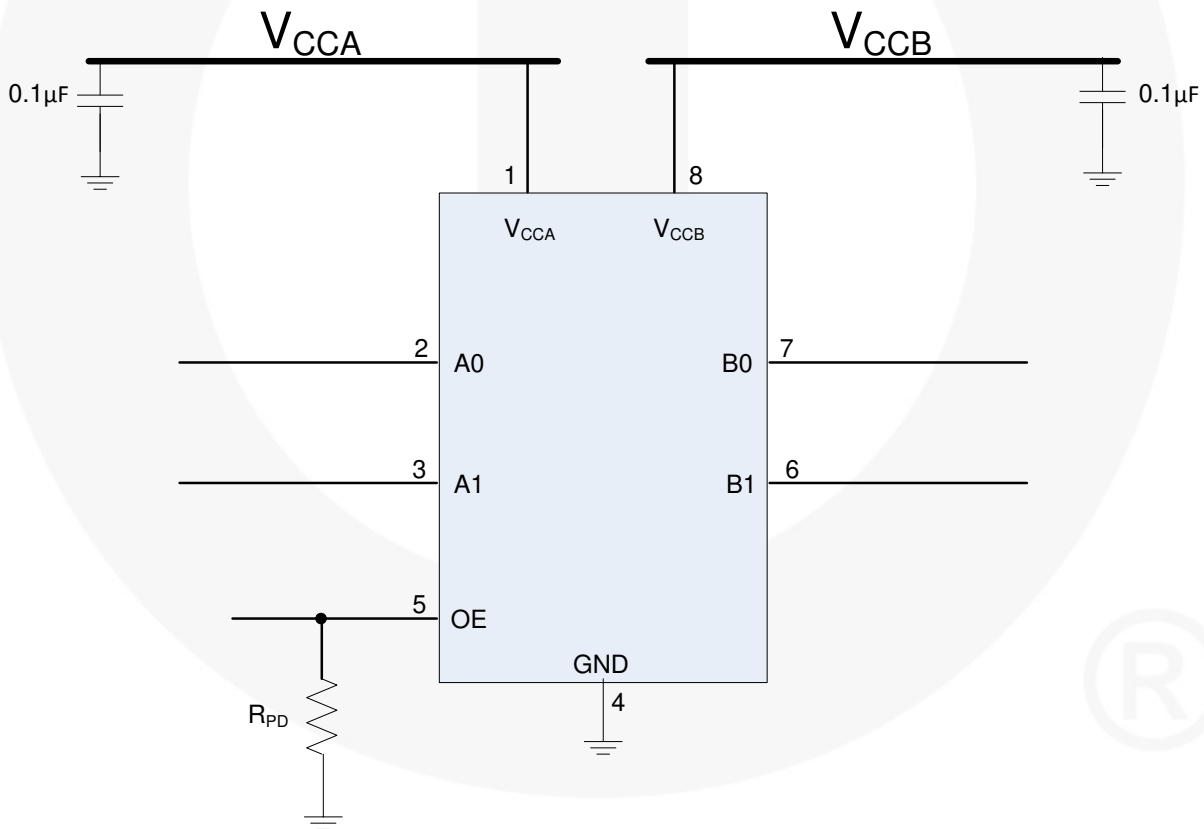


Figure 4. Application Circuit

## Application Information

The FXMAR2102 has open-drain I/Os and includes a total of four 10 K $\Omega$  internal pull-up resistors ( $R_{PU}$ ) on each of the four data I/O pins, as shown in Figure 4. If a pair of data I/O pins ( $A_n/B_n$ ) is not used, both pins should be disconnected, eliminating unwanted current flow through the internal RPU's. External RPU's can be added to the I/Os to reduce the total RPU value, depending on the total bus capacitance. The designer is free to lower the total pull-up resistor value to meet the maximum I<sup>2</sup>C edge rate per the I<sup>2</sup>C specification (*UM10204 rev. 03, June 19, 2007*). For example, according to the I<sup>2</sup>C specification, the maximum edge rate (30% - 70%) during Fast Mode (400 kbit/s) is 300 ns. If the bus capacitance is approaching the maximum 400 pF, a lower total  $R_{PU}$  value helps keep the rise time below 300 ns (Fast Mode). Likewise, the I<sup>2</sup>C specification also specifies a minimum Serial Clock Line High Time of 600 ns during Fast Mode (400 KHz). Lowering the total RPU also helps increase the SCL High Time. If the bus capacitance approaches 400 pF, it may make sense to use the FXMA2102, which does not contain internal RPU's. Then calculate the ideal external  $R_{PU}$  value.

### Note:

- Section 7.1 of the I<sup>2</sup>C specification provides an excellent guideline for pull-up resistor sizing.

## Theory of Operation

The FXMAR2102 is designed for high-performance level shifting and buffer / repeating in an I<sup>2</sup>C application. Figure 1 shows that each bi-directional channel contains two series-Npassgates and two dynamic drivers. This hybrid architecture is highly beneficial in an I<sup>2</sup>C application where auto-direction is a necessity.

For example, during the following three I<sup>2</sup>C protocol events:

- Clock Stretching
- Slave's ACK Bit (9<sup>th</sup> bit = 0) following a Master's Write Bit (8<sup>th</sup> bit = 0)
- Clock Synchronization and Multi-Master Arbitration

the bus direction needs to change from master-to-slave to slave-to-master without the occurrence of an edge. If there is an I<sup>2</sup>C translator between the master and slave in these examples, the I<sup>2</sup>C translator must change direction when both A and B ports are LOW. The Npassgates can accomplish this task very efficiently because, when both A and B ports are LOW, the Npassgates act as a low-resistive short between the A and B ports.

Due to I<sup>2</sup>C's open-drain topology, I<sup>2</sup>C masters and slaves are not push/pull drivers. Logic LOWs are "pulled down" ( $I_{sink}$ ), while logic HIGHs are "let go" (3-state). For example, when the master lets go of SCL (SCL always comes from the master), the rise time of SCL is largely determined by the RC time constant, where  $R = R_{PU}$  and  $C =$  the bus capacitance. If the FXMAR2102 is attached to the master [on the A port] and there is a slave on the B port, the Npassgates act as a low-resistive short between both ports until either of the port's  $V_{CC}/2$  thresholds are reached. After the RC time constant has reached the  $V_{CC}/2$  threshold of either port, the port's edge detector triggers both dynamic drivers to drive their respective ports in the LOW-to-HIGH (LH) direction, accelerating the rising edge. The resulting rise time resembles the scope shot in Figure 5. Effectively, two distinct slew rates appear in rise time. The first slew rate (slower) is the RC time constant of the bus. The second slew rate (much faster) is the dynamic driver accelerating the edge.

If both the A and B ports of the translator are HIGH, a high-impedance path exists between the A and B ports because both the Npassgates are turned off. If a master or slave device decides to pull SCL or SDA LOW, that device's driver pulls down ( $I_{sink}$ ) SCL or SDA until the edge reaches the A or B port  $V_{CC}/2$  threshold. When either the A or B port threshold is reached, the port's edge detector triggers both dynamic drivers to drive their respective ports in the HIGH-to-LOW (HL) direction, accelerating the falling edge.

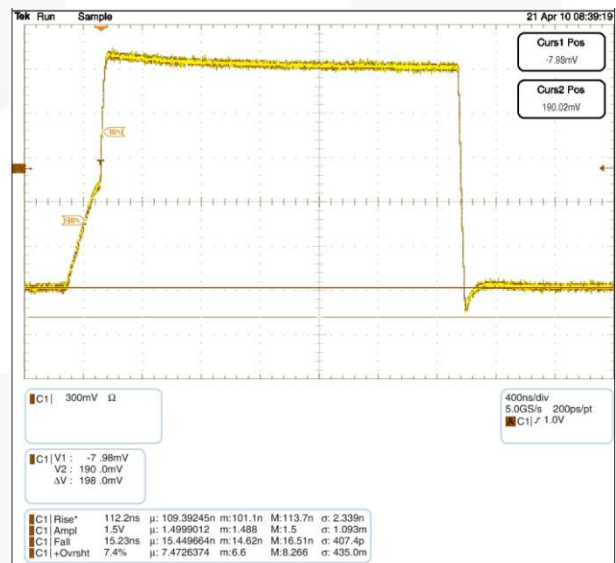


Figure 5. Waveform C: 600 pF, Total  $R_{PU}$ : 2.2 K $\Omega$



### V<sub>OL</sub> vs. I<sub>OL</sub>

The I<sup>2</sup>C specification mandates a maximum V<sub>IL</sub> (I<sub>OL</sub> of 3 mA) of V<sub>CC</sub> • 0.3 and a maximum V<sub>OL</sub> of 0.4 V. If there is a master on the A port of an I<sup>2</sup>C translator with a V<sub>CC</sub> of 1.65 V and a slave on the I<sup>2</sup>C translator B port with a V<sub>CC</sub> of 3.3 V, the maximum V<sub>IL</sub> of the master is (1.65 V x 0.3) 495 mV. The slave could legally transmit a valid logic LOW of 0.4 V to the master.

If the I<sup>2</sup>C translator's channel resistance is too high, the voltage drop across the translator could present a V<sub>IL</sub> to the master greater than 495 mV. To complicate matters, the I<sup>2</sup>C specification states that 6 mA of I<sub>OL</sub> is recommended for bus capacitances approaching 400 pF. More I<sub>OL</sub> increases the voltage drop across the I<sup>2</sup>C translator. The I<sup>2</sup>C application benefits when I<sup>2</sup>C translators exhibit low V<sub>OL</sub> performance. Figure 6 depicts typical FXMAR2102 V<sub>OL</sub> performance vs. the competition, given a 0.4 V V<sub>IL</sub>.

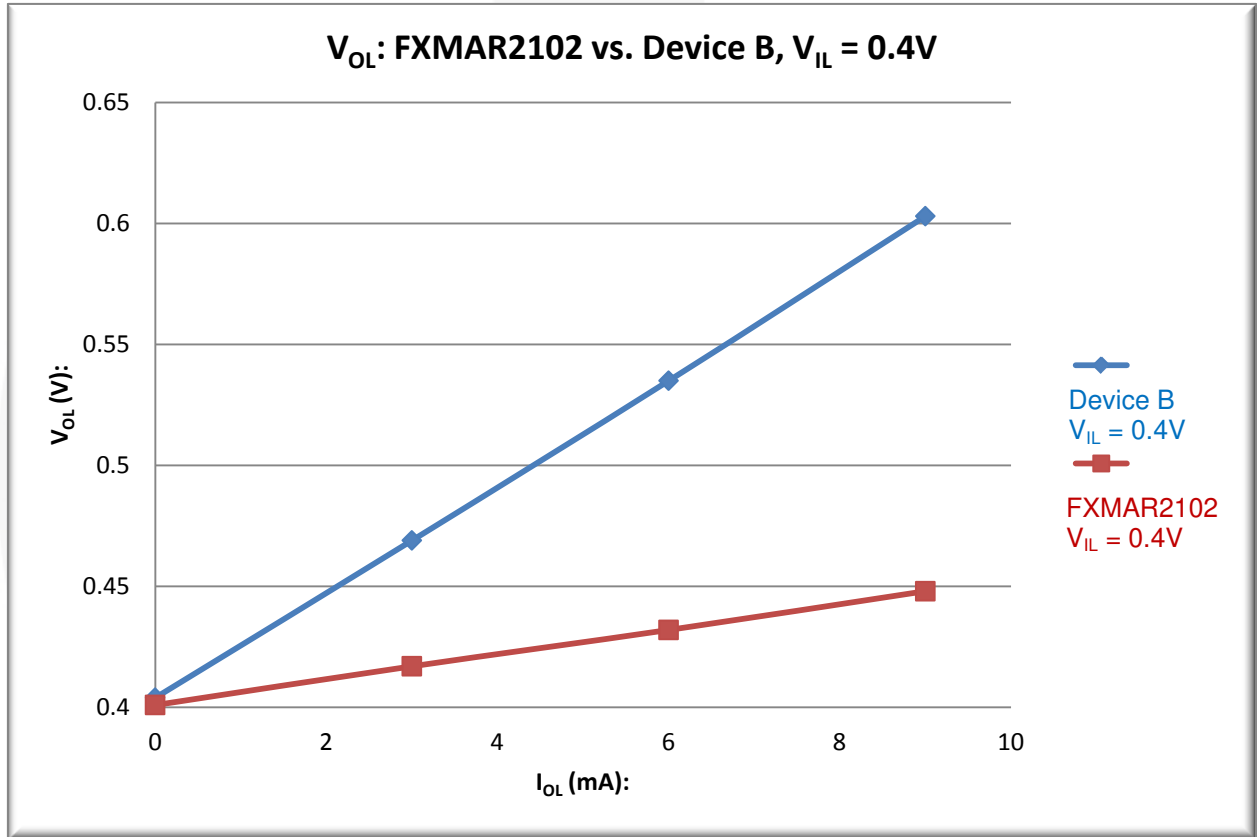


Figure 6. Device Comparison

## I<sup>2</sup>C Bus Isolation

The FXMAR2102 supports I<sup>2</sup>C-Bus<sup>®</sup> isolation for the following conditions:

- Bus isolation if bus clear
- Bus isolation if either V<sub>CC</sub> goes to ground

### Bus Clear

Because the I<sup>2</sup>C specification defines the minimum SCL frequency of DC, the SCL signal can be held LOW forever; however. This condition shuts down the I<sup>2</sup>C bus. The I<sup>2</sup>C specification refers to this condition as “Bus Clear.” In Figure 7; if slave #2 holds down SCL forever, the master and slave #1 are not able to communicate because the FXMAR2102 passes the SCL stuck-LOW condition from slave #2 to slave #1 and as the master.

However, if the OE pin is pulled LOW (disabled), both ports (A and B) are 3-stated. This results in the FXMAR2102 isolating slave #2 from the master and slave #1, allowing full communication between the master and slave #1.

### V<sub>CC</sub> to GND

If slave #2 is a camera that is suddenly removed from the I<sup>2</sup>C bus, resulting in V<sub>CCB</sub> transitioning from a valid V<sub>CC</sub> (1.65 V – 5.5 V) to 0 V; the FXMAR2102 automatically forces SCL and SDA on both its A and B ports into 3-state. Once V<sub>CCB</sub> has reached 0 V, full I<sup>2</sup>C communication between the master and slave #1 remains undisturbed.

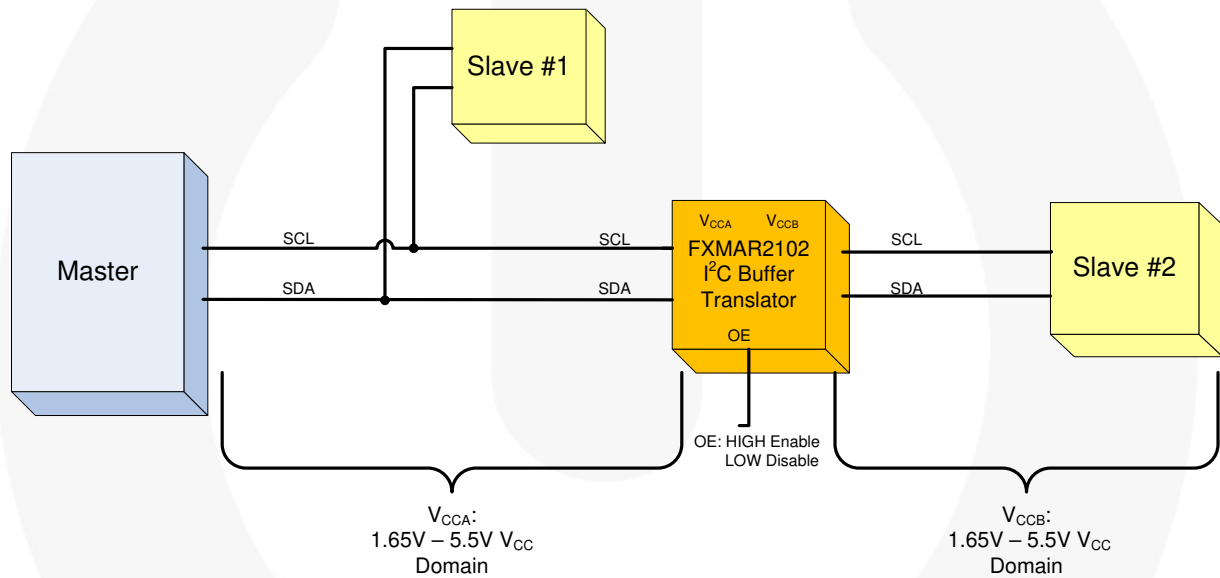


Figure 7. Bus Isolation

## DC Electrical Characteristics

T<sub>A</sub> = -40°C to +85°C.

Symbol	Parameter	Conditions	V <sub>CCA</sub> (V)	V <sub>CCB</sub> (V)	Min.	Typ.	Max.	Units
V <sub>IHA</sub>	High Level Input Voltage A	Data Inputs A <sub>n</sub>	1.65–5.50	1.65–5.50	V <sub>CCA</sub> – 0.4			V
		Control Input OE	1.65–5.50	1.65–5.50	0.7 × V <sub>CCA</sub>			
V <sub>IHB</sub>	High Level Input Voltage B	Data Inputs B <sub>n</sub>	1.65–5.50	1.65–5.50	V <sub>CCB</sub> – 0.4			V
V <sub>ILA</sub>	Low Level Input Voltage A	Data Inputs A <sub>n</sub>	1.65–5.50	1.65–5.50			0.4	V
		Control Input OE	1.65–5.50	1.65–5.50			0.3 × V <sub>CCA</sub>	
V <sub>ILB</sub>	Low Level Input Voltage B	Data Inputs B <sub>n</sub>	1.65–5.50	1.65–5.50			0.4	V
V <sub>OL</sub>	Low Level Output Voltage	V <sub>IL</sub> = 0.15 V	1.65–5.50	1.65–5.50			0.4	V
		I <sub>OL</sub> = 6 mA						
I <sub>L</sub>	Input Leakage Current	Control Input OE, V <sub>IN</sub> = V <sub>CCA</sub> or GND	1.65–5.50	1.65–5.50			±1.0	μA
I <sub>OFF</sub>	Power-Off Leakage Current	A <sub>n</sub> V <sub>IN</sub> or V <sub>O</sub> = 0 V to 5.5 V	0	5.50			±2.0	μA
		B <sub>n</sub> V <sub>IN</sub> or V <sub>O</sub> = 0 V to 5.5 V	5.50	0			±2.0	
I <sub>OZ</sub>	3-State Output Leakage <sup>(7)</sup>	A <sub>n</sub> , B <sub>n</sub> V <sub>O</sub> = 0 V to 5.5 V, OE = V <sub>IL</sub>	5.50	5.50			±2.0	μA
		A <sub>n</sub> V <sub>O</sub> = 0 V to 5.5 V, OE = Don't Care	5.50	0			±2.0	
		B <sub>n</sub> V <sub>O</sub> = 0 V to 5.5 V, OE = Don't Care	0	5.50			±2.0	
I <sub>CCA/B</sub>	Quiescent Supply Current <sup>(8,9)</sup>	V <sub>IN</sub> = V <sub>CCI</sub> or Floating, I <sub>O</sub> = 0	1.65–5.50	1.65–5.50			5.0	μA
I <sub>CCZ</sub>	Quiescent Supply Current <sup>(8)</sup>	V <sub>IN</sub> = V <sub>CCI</sub> or GND, I <sub>O</sub> = 0, OE = V <sub>IL</sub>	1.65–5.50	1.65–5.50			5.0	μA
I <sub>CCA</sub>	Quiescent Supply Current <sup>(7)</sup>	V <sub>IN</sub> = 5.5 V or GND, I <sub>O</sub> = 0, OE = Don't Care, B <sub>n</sub> to A <sub>n</sub>	0	1.65–5.50			-2.0	μA
			1.65–5.50	0			2.0	
I <sub>CCB</sub>	Quiescent Supply Current <sup>(7)</sup>	V <sub>IN</sub> = 5.5 V or GND, I <sub>O</sub> = 0, OE = Don't Care, A <sub>n</sub> to B <sub>n</sub>	1.65–5.50	0			-2.0	μA
			0	1.65–5.50			2.0	
R <sub>PU</sub>	Resistor Pull-up Value	VCCA & VCCB Sides	1.65–5.50	1.65–5.50		10		Ω

### Notes:

- This table contains the output voltage for static conditions. Dynamic drive specifications are given in Dynamic Output Electrical Characteristics.
- "Don't Care" indicates any valid logic level.
- V<sub>CCI</sub> is the V<sub>CC</sub> associated with the input side.
- Reflects current per supply, V<sub>CCA</sub> or V<sub>CCB</sub>.

## Dynamic Output Electrical Characteristics

### Output Rise / Fall Time<sup>(10)</sup>

Output load:  $C_L = 50$  pF,  $R_{PU} = NC$ , push / pull driver, and  $T_A = -40^\circ\text{C}$  to  $+85^\circ\text{C}$ .

Symbol	Parameter	$V_{CCO}^{(11)}$				Unit
		4.5 to 5.5 V	3.0 to 3.6 V	2.3 to 2.7 V	1.65 to 1.95 V	
		Typ.	Typ.	Typ.	Typ.	
$t_{rise}$	Output Rise Time; A Port, B Port <sup>(12)</sup>	3	4	5	7	ns
$t_{fall}$	Output Fall Time; A Port, B Port <sup>(13)</sup>	1	1	1	1	ns

#### Notes:

10. Output rise and fall times guaranteed by design simulation and characterization; not production tested.
11.  $V_{CCO}$  is the  $V_{CC}$  associated with the output side.
12. See Figure 12.
13. See Figure 13.

### Maximum Data Rate<sup>(14)</sup>

Output load:  $C_L = 50$  pF,  $R_{PU} = NC$ , push / pull driver, and  $T_A = -40^\circ\text{C}$  to  $+85^\circ\text{C}$ .

$V_{CCA}$	Direction	$V_{CCB}$				Unit
		4.5 to 5.5 V	3.0 to 3.6 V	2.3 to 2.7 V	1.65 to 1.95 V	
		Minimums				
4.5 V to 5.5 V	A to B	50	50	40	30	MHz
	B to A	50	50	40	40	
3.0 V to 3.6 V	A to B	50	50	40	19	MHz
	B to A	50	50	40	40	
2.3 V to 2.7 V	A to B	40	40	30	19	MHz
	B to A	40	40	30	30	
1.65 V to 1.95 V	A to B	40	40	30	19	MHz
	B to A	30	30	19	19	

#### Note:

14. F-toggle guaranteed by design simulation; not production tested.

### AC Characteristics<sup>(15)</sup>

Output Load:  $C_L = 50$  pF,  $R_{PU} = NC$ , push / pull driver, and  $T_A = -40^\circ\text{C}$  to  $+85^\circ\text{C}$ .

Symbol	Parameter	$V_{CCB}$								Unit
		4.5 to 5.5 V		3.0 to 3.6 V		2.3 to 2.7 V		1.65 to 1.95 V		
		Typ.	Max.	Typ.	Max.	Typ.	Max.	Typ.	Max.	
<b><math>V_{CCA} = 4.5</math> to <math>5.5</math> V</b>										
$t_{PLH}$	A to B	1	3	1	3	1	3	1	3	ns
	B to A	1	3	2	4	3	5	4	7	
$t_{PHL}$	A to B	2	4	3	5	4	6	5	7	ns
	B to A	2	4	2	5	2	6	5	7	
$t_{PZL}$	OE to A	4	5	6	10	5	9	7	15	ns
	OE to B	3	5	4	7	5	8	10	15	
$t_{PLZ}$	OE to A	65	100	65	105	65	105	65	105	ns
	OE to B	5	9	6	10	7	12	9	16	
$t_{skew}$	A Port, B Port <sup>(16)</sup>	0.50	1.50	0.50	1.00	0.50	1.00	0.50	1.00	ns
<b><math>V_{CCA} = 3.0</math> to <math>3.6</math> V</b>										
$t_{PLH}$	A to B	2.0	5.0	1.5	3.0	1.5	3.0	1.5	3.0	ns
	B to A	1.5	3.0	1.5	4.0	2.0	6.0	3.0	9.0	
$t_{PHL}$	A to B	2.0	4.0	2.0	4.0	2.0	5.0	3.0	5.0	ns
	B to A	2.0	4.0	2.0	4.0	2.0	5.0	3.0	5.0	
$t_{PZL}$	OE to A	4.0	8.0	5.0	9.0	6.0	11.0	7.0	15.0	ns
	OE to B	4.0	8.0	6.0	9.0	8.0	11.0	10.0	14.0	
$t_{PLZ}$	OE to A	100	115	100	115	100	115	100	115	ns
	OE to B	5	10	4	8	5	10	9	15	
$t_{skew}$	A Port, B Port <sup>(16)</sup>	0.5	1.5	0.5	1.0	0.5	1.0	0.5	1.0	ns
<b><math>V_{CCA} = 2.3</math> to <math>2.7</math> V</b>										
$t_{PLH}$	A to B	2.5	5.0	2.5	5.0	2.0	4.0	1.0	3.0	ns
	B to A	1.5	3.0	2.0	4.0	3.0	6.0	5.0	10.0	
$t_{PHL}$	A to B	2.0	5.0	2.0	5.0	2.0	5.0	3.0	6.0	ns
	B to A	2.0	5.0	2.0	5.0	2.0	5.0	3.0	6.0	
$t_{PZL}$	OE to A	5.0	10.0	5.0	10.0	6.0	12.0	9.0	18.0	ns
	OE to B	4.0	8.0	4.5	9.0	5.0	10.0	9.0	18.0	
$t_{PLZ}$	OE to A	100	115	100	115	100	115	100	115	ns
	OE to B	65	110	65	110	65	115	12	25	
$t_{skew}$	A Port, B Port <sup>(16)</sup>	0.5	1.5	0.5	1.0	0.5	1.0	0.5	1.0	ns
<b><math>V_{CCA} = 1.65</math> to <math>1.95</math> V</b>										
$t_{PLH}$	A to B	4	7	4	7	5	8	5	10	ns
	B to A	1.0	2.0	1.0	2.0	1.5	3.0	5.0	10.0	
$t_{PHL}$	A to B	5	8	3	7	3	7	3	7	ns
	B to A	4	8	3	7	3	7	3	7	
$t_{PZL}$	OE to A	11	15	11	14	14	28	14	23	ns
	OE to B	6	14	6	14	6	14	9	16	
$t_{PLZ}$	OE to A	75	115	75	115	75	115	75	115	ns
	OE to B	75	115	75	115	75	115	75	115	
$t_{skew}$	A Port, B Port <sup>(16)</sup>	0.5	1.5	0.5	1.0	0.5	1.0	0.5	1.0	ns

**Notes:**

15. AC characteristics are guaranteed by design and characterization.
16. Skew is the variation of propagation delay between output signals and applies only to output signals on the same port ( $A_n$  or  $B_n$ ) and switching with the same polarity (LOW-to-HIGH or HIGH-to-LOW) (see Figure 15). Skew is guaranteed; not production tested.

## Capacitance

T<sub>A</sub> = +25°C.

Symbol	Parameter	Conditions	Typical	Units
C <sub>IN</sub>	Input Capacitance Control Pin (OE)	V <sub>CCA</sub> = V <sub>CCB</sub> = GND	2.2	pF
C <sub>I/O</sub>	Input/Output Capacitance, A <sub>n</sub> , B <sub>n</sub>	V <sub>CCA</sub> = V <sub>CCB</sub> = 5.0 V, OE = GND	13	pF

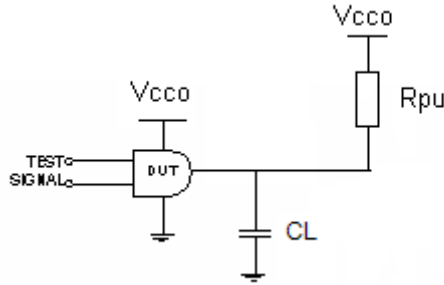


Figure 8. AC Test Circuit

Table 1. Propagation Delay Table<sup>(17)</sup>

Test	Input Signal	Output Enable Control
t <sub>PLH</sub> , t <sub>PHL</sub>	Data Pulses	V <sub>CCA</sub>
t <sub>PZL</sub> (OE to A <sub>n</sub> , B <sub>n</sub> )	0 V	LOW to HIGH Switch
t <sub>PLZ</sub> (OE to A <sub>n</sub> , B <sub>n</sub> )	0 V	HIGH to LOW Switch

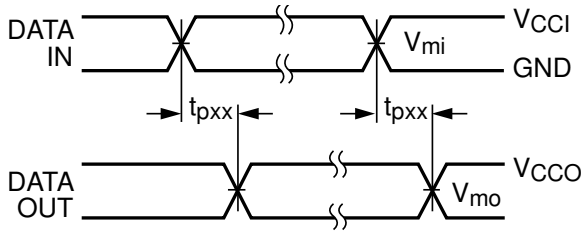
**Note:**

17. For t<sub>PZL</sub> and t<sub>PLZ</sub> testing, an external 2.2 KΩ pull-up resistor to V<sub>CCO</sub> is required in order to force the I/O pins high while OE is Low because when OE is low, the internal 10KΩ RPU's are decoupled from their respective VCC's.

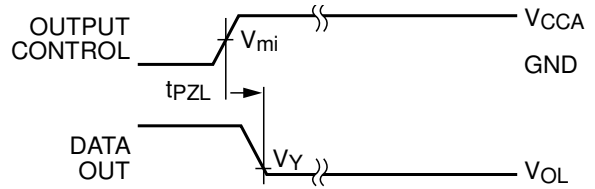
Table 2. AC Load Table

V <sub>CCO</sub>	C <sub>L</sub>	R <sub>L</sub>
1.8 ±0.15 V	50 pF	NC
2.5 ±0.2 V	50 pF	NC
3.3 ±0.3 V	50 pF	NC
5.0 ±0.5 V	50 pF	NC

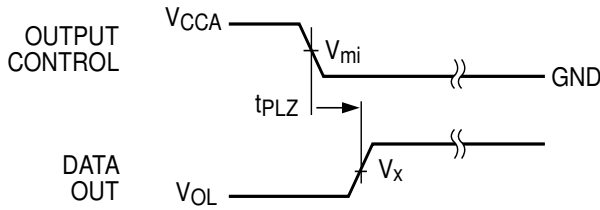
### Timing Diagrams



**Figure 9. Waveform for Inverting and Non-Inverting Functions**<sup>(18)</sup>

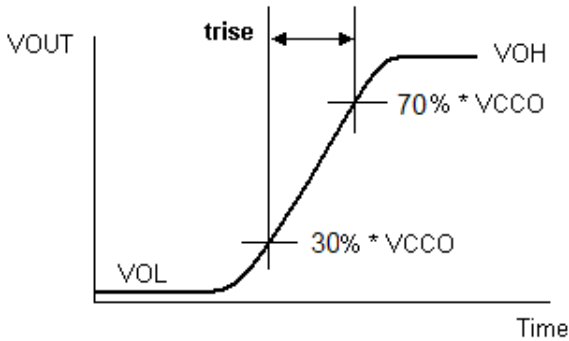


**Figure 10.3-STATE Output Low Enable Time**<sup>(18)</sup>

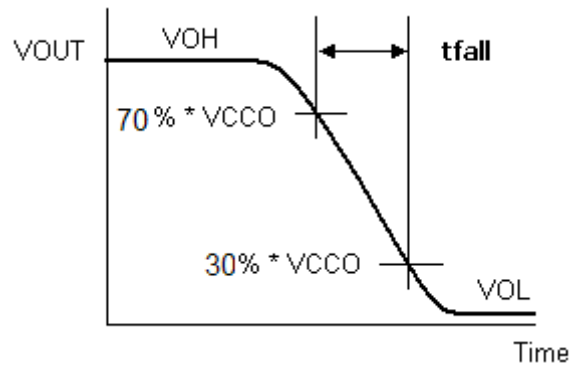


**Figure 11.3-STATE Output High Enable Time**<sup>(18)</sup>

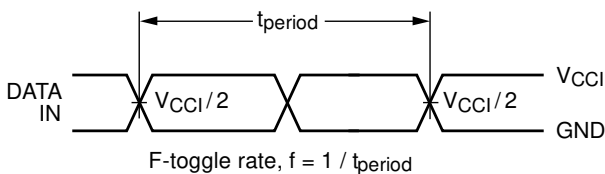
Symbol	V <sub>CC</sub>
V <sub>mi</sub> <sup>(19)</sup>	V <sub>CCI</sub> / 2
V <sub>mo</sub>	V <sub>CCO</sub> / 2
V <sub>x</sub>	0.5 x V <sub>CCO</sub>
V <sub>y</sub>	0.1 x V <sub>CCO</sub>



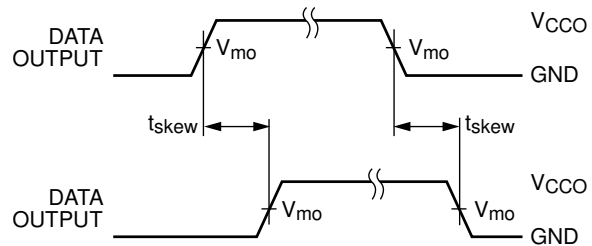
**Figure 12.Active Output Rise Time**



**Figure 13.Active Output Fall Time**



**Figure 14.F-Toggle Rate**



$$t_{skew} = (t_{pHLmax} - t_{pHLmin}) \text{ or } (t_{pLHmax} - t_{pLHmin})$$

**Figure 15.Output Skew Time**

**Notes:**

- 18. Input  $t_R = t_F = 2.0$  ns, 10% to 90% at  $V_{IN} = 1.65$  V to 1.95 V;  
 Input  $t_R = t_F = 2.0$  ns, 10% to 90% at  $V_{IN} = 2.3$  to 2.7 V;  
 Input  $t_R = t_F = 2.5$  ns, 10% to 90%, at  $V_{IN} = 3.0$  V to 3.6 V only;  
 Input  $t_R = t_F = 2.5$  ns, 10% to 90%, at  $V_{IN} = 4.5$  V to 5.5 only.
- 19.  $V_{CCI} = V_{CCA}$  for control pin OE or  $V_{mi} = (V_{CCA} / 2)$ .

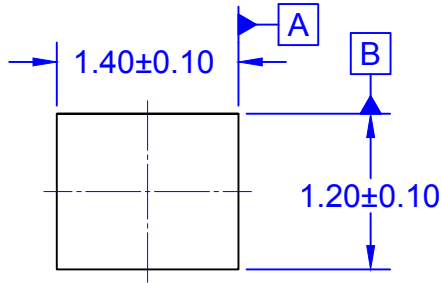
**Product-Specific Dimensions**

Symbol from JEDEC MO-220	Description	NOM Value
A	Overall Height	0.55
A1	PKG Standoff	0.012
A3	Lead Thickness	0.15
b	Lead Width	0.2
D	Body Length (X)	1.4
E	Body Width (Y)	1.2
L	Lead Length	0.3
e	Lead Pitch	0.4

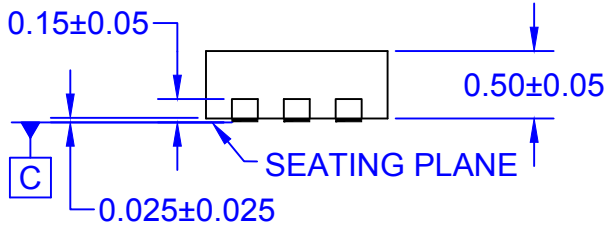
Package drawings are provided as a service to customers considering Fairchild components. Drawings may change in any manner without notice. Please note the revision and/or date on the drawing and contact a Fairchild Semiconductor representative to verify or obtain the most recent revision. Package specifications do not expand the terms of Fairchild's worldwide terms and conditions, specifically the warranty therein, which covers Fairchild products.

Always visit Fairchild Semiconductor's online packaging area for the most recent package drawings:  
<http://www.fairchildsemi.com/packaging/>.

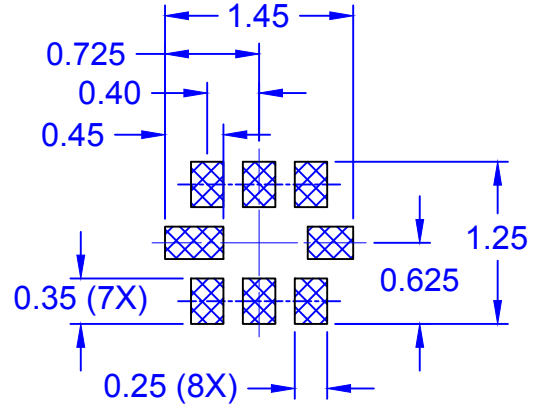




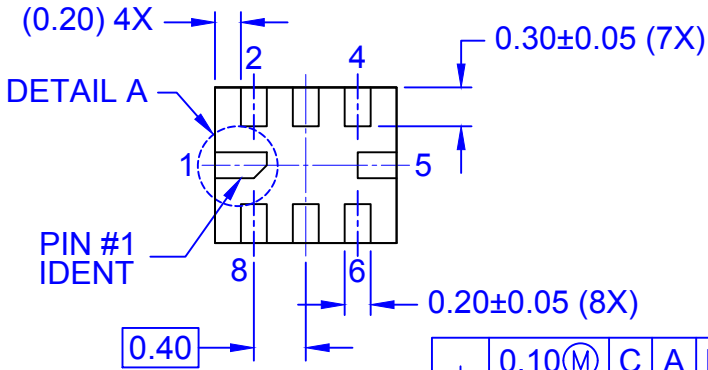
TOP VIEW



SIDE VIEW

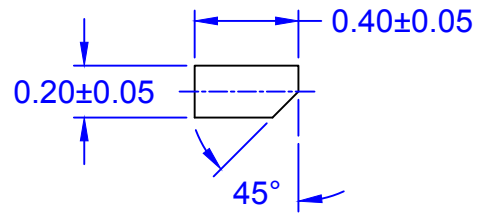


RECOMMENDED LAND PATTERN



BOTTOM VIEW

⌀	0.10(M)	C	A	B
	0.05(M)	C		

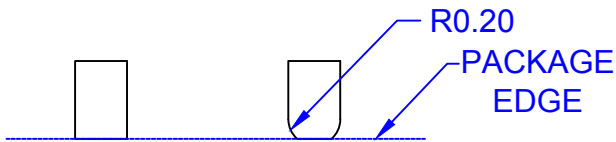


DETAIL A  
SCALE : 2X

NOTES:

- A. PACKAGE DOES NOT FULLY CONFORM TO JEDEC STANDARD.
- B. DIMENSIONS ARE IN MILLIMETERS.
- C. LAND PATTERN RECOMMENDATION IS EXISTING INDUSTRY LAND PATTERN.
- D. DRAWING FILENAME: MKT-UMLP08ArevD

LEAD SHAPE AT PACKAGE EDGE

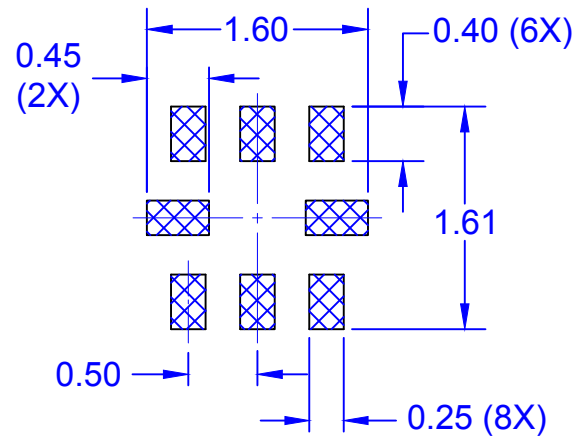
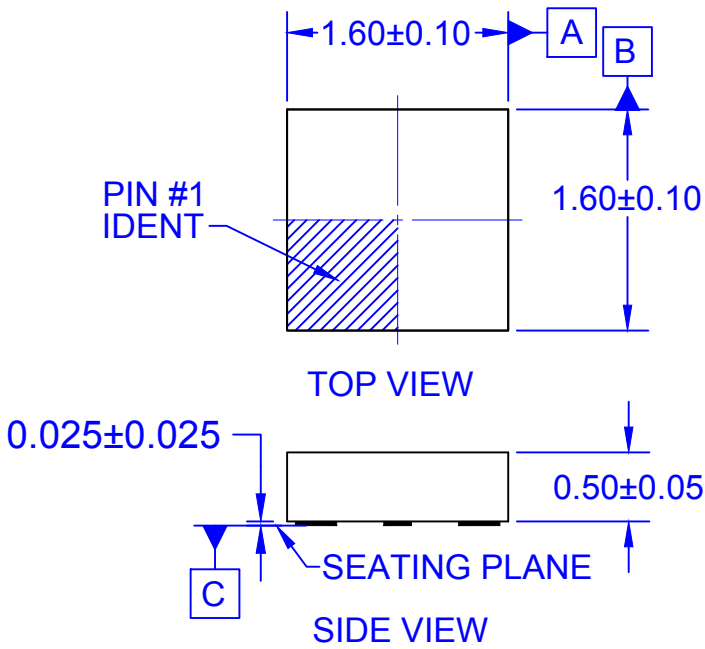


LEAD  
OPTION 1  
SCALE : 2X

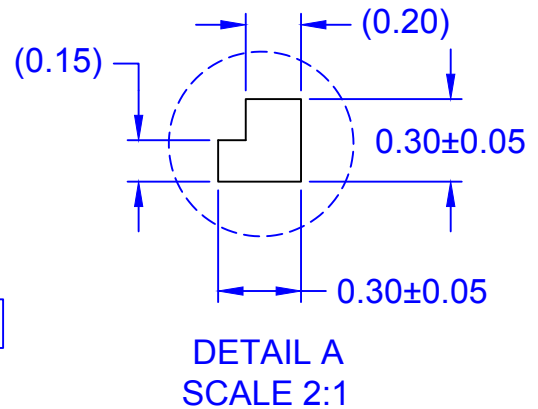
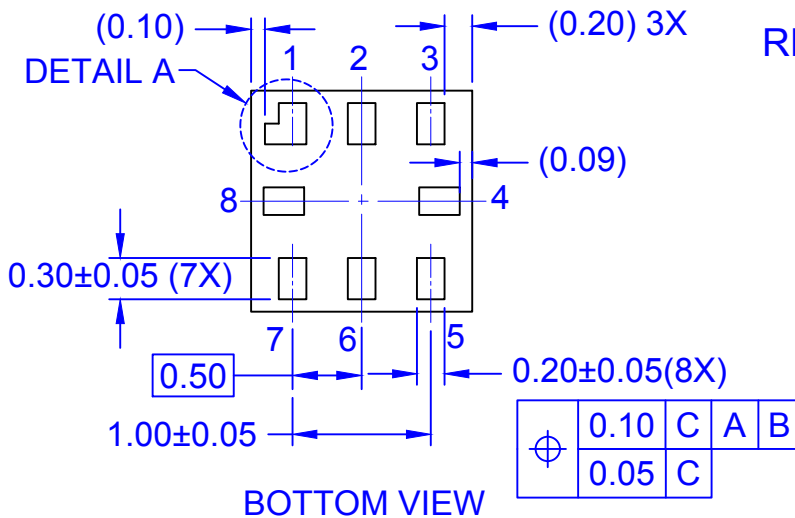
LEAD  
OPTION 2  
SCALE : 2X

**ON Semiconductor**





RECOMMENDED LAND PATTERN



NOTES:

- A. PACKAGE CONFORMS TO JEDEC MO-255 VARIATION UAAD.
- B. DIMENSIONS ARE IN MILLIMETERS.
- C. LAND PATTERN RECOMMENDATION IS EXISTING INDUSTRY LAND PATTERN.
- D. DRAWING FILENAME: MKT-MAC08ArevE.

ON Semiconductor



ON Semiconductor and  are trademarks of Semiconductor Components Industries, LLC dba ON Semiconductor or its subsidiaries in the United States and/or other countries. ON Semiconductor owns the rights to a number of patents, trademarks, copyrights, trade secrets, and other intellectual property. A listing of ON Semiconductor's product/patent coverage may be accessed at [www.onsemi.com/site/pdf/Patent-Marking.pdf](http://www.onsemi.com/site/pdf/Patent-Marking.pdf). ON Semiconductor reserves the right to make changes without further notice to any products herein. ON Semiconductor makes no warranty, representation or guarantee regarding the suitability of its products for any particular purpose, nor does ON Semiconductor assume any liability arising out of the application or use of any product or circuit, and specifically disclaims any and all liability, including without limitation special, consequential or incidental damages. Buyer is responsible for its products and applications using ON Semiconductor products, including compliance with all laws, regulations and safety requirements or standards, regardless of any support or applications information provided by ON Semiconductor. "Typical" parameters which may be provided in ON Semiconductor data sheets and/or specifications can and do vary in different applications and actual performance may vary over time. All operating parameters, including "Typicals" must be validated for each customer application by customer's technical experts. ON Semiconductor does not convey any license under its patent rights nor the rights of others. ON Semiconductor products are not designed, intended, or authorized for use as a critical component in life support systems or any FDA Class 3 medical devices or medical devices with a same or similar classification in a foreign jurisdiction or any devices intended for implantation in the human body. Should Buyer purchase or use ON Semiconductor products for any such unintended or unauthorized application, Buyer shall indemnify and hold ON Semiconductor and its officers, employees, subsidiaries, affiliates, and distributors harmless against all claims, costs, damages, and expenses, and reasonable attorney fees arising out of, directly or indirectly, any claim of personal injury or death associated with such unintended or unauthorized use, even if such claim alleges that ON Semiconductor was negligent regarding the design or manufacture of the part. ON Semiconductor is an Equal Opportunity/Affirmative Action Employer. This literature is subject to all applicable copyright laws and is not for resale in any manner.

## PUBLICATION ORDERING INFORMATION

### LITERATURE FULFILLMENT:

Literature Distribution Center for ON Semiconductor  
19521 E. 32nd Pkwy, Aurora, Colorado 80011 USA  
**Phone:** 303-675-2175 or 800-344-3860 Toll Free USA/Canada  
**Fax:** 303-675-2176 or 800-344-3867 Toll Free USA/Canada  
**Email:** [orderlit@onsemi.com](mailto:orderlit@onsemi.com)

**N. American Technical Support:** 800-282-9855 Toll Free  
USA/Canada  
**Europe, Middle East and Africa Technical Support:**  
Phone: 421 33 790 2910  
**Japan Customer Focus Center**  
Phone: 81-3-5817-1050

**ON Semiconductor Website:** [www.onsemi.com](http://www.onsemi.com)  
**Order Literature:** <http://www.onsemi.com/orderlit>  
For additional information, please contact your local  
Sales Representative