



Chipsmall Limited consists of a professional team with an average of over 10 year of expertise in the distribution of electronic components. Based in Hongkong, we have already established firm and mutual-benefit business relationships with customers from,Europe,America and south Asia,supplying obsolete and hard-to-find components to meet their specific needs.

With the principle of “Quality Parts,Customers Priority,Honest Operation,and Considerate Service”,our business mainly focus on the distribution of electronic components. Line cards we deal with include Microchip,ALPS,ROHM,Xilinx,Pulse,ON,Everlight and Freescale. Main products comprise IC,Modules,Potentiometer,IC Socket,Relay,Connector.Our parts cover such applications as commercial,industrial, and automotives areas.

We are looking forward to setting up business relationship with you and hope to provide you with the best service and solution. Let us make a better world for our industry!



Contact us

Tel: +86-755-8981 8866 Fax: +86-755-8427 6832

Email & Skype: info@chipsmall.com Web: www.chipsmall.com

Address: A1208, Overseas Decoration Building, #122 Zhenhua RD., Futian, Shenzhen, China



SPECIFICATION

- Part No. : **FXR.07.A.dg**
- Product Name : Circular Near-Field Communications Antenna
with Ferrite Layer for Metal Direct Mount
- Features : 13.56 MHz NFC Antenna
Can be placed directly on metal surfaces
Layered with Ferrite Flux Director
Low Profile Embedded Antenna
Dimensions:
 - Diameter: 45.5 mm
 - Thickness: 0.30 mmPeel and stick Nitto UTD-30 adhesive on back
RoHS Compliant





1. Introduction

The FXR.07.A.dg is a rectangular, embedded, NFC (Near Field Communications) antenna for use in IoT devices such as keycards, payment systems, and readers. The design provides a flexible NFC antenna that can be adhered to metallic parts or directly to the battery of the device for ease of installation.

NFC antennas can be applied in areas not traditionally available to other types of antennas. A common example is the ability to apply NFC antennas to batteries or other conductive surfaces. To enable this usage, however, a ferrite flux director layer is required. This ferrite layer acts to steer the magnetic flux away from the metal or other conductor, where it would otherwise result in loss or complete failure to communicate. Taoglas NFC antennas can therefore be customized with flux director layers to enable this flexibility in usage. The coil inductance noted below can help estimate a capacitance value for creating resonance at 13.56MHz.

Typical applications

- Mobile devices
- Electronic wallets
- Health care ID scanners
- Payment readers
- Office ID
- Access control
- Internet Of Things

Customized antennas for specific applications, shape, and impedance match can also be provided for a NRE and are subject to MOQ. Contact your regional Taoglas sales office for more information and support on our NFC antenna range.

2. Specifications

Flexible PCB Near-Field Communications Antenna		
Frequency	13.56	MHz
Inductance @ 13.56 MHz	6.4	μ H
Flexible NFC Mechanical		
Antenna Dimensions	Diameter: 45.5 mm Thickness: 0.15 mm	
Adhesive	3M 467	
Weight	2g	
Ferrite Sheet Mechanical		
PET	Diameter: 45.5 mm Thickness: 0.02 mm	
Ferrite Sheet	Diameter: 45.5 mm Thickness: 0.10 mm	
Adhesive Type	Nitto UTD-30 (W) Thickness: 0.03 mm	
Environmental		
Operation Temperature	-40°C to 85°C	
Storage Temperature	-40°C to 85°C	
Humidity	Non-condensing 65°C 95% RH	

3. Antenna Application

3.1. Test setup

A test fixture is used to measure the maximum interrogation distance. The FXR.07.A.dg antenna is connected to a NFC evaluation board and then placed on the fixed part of the fixture.

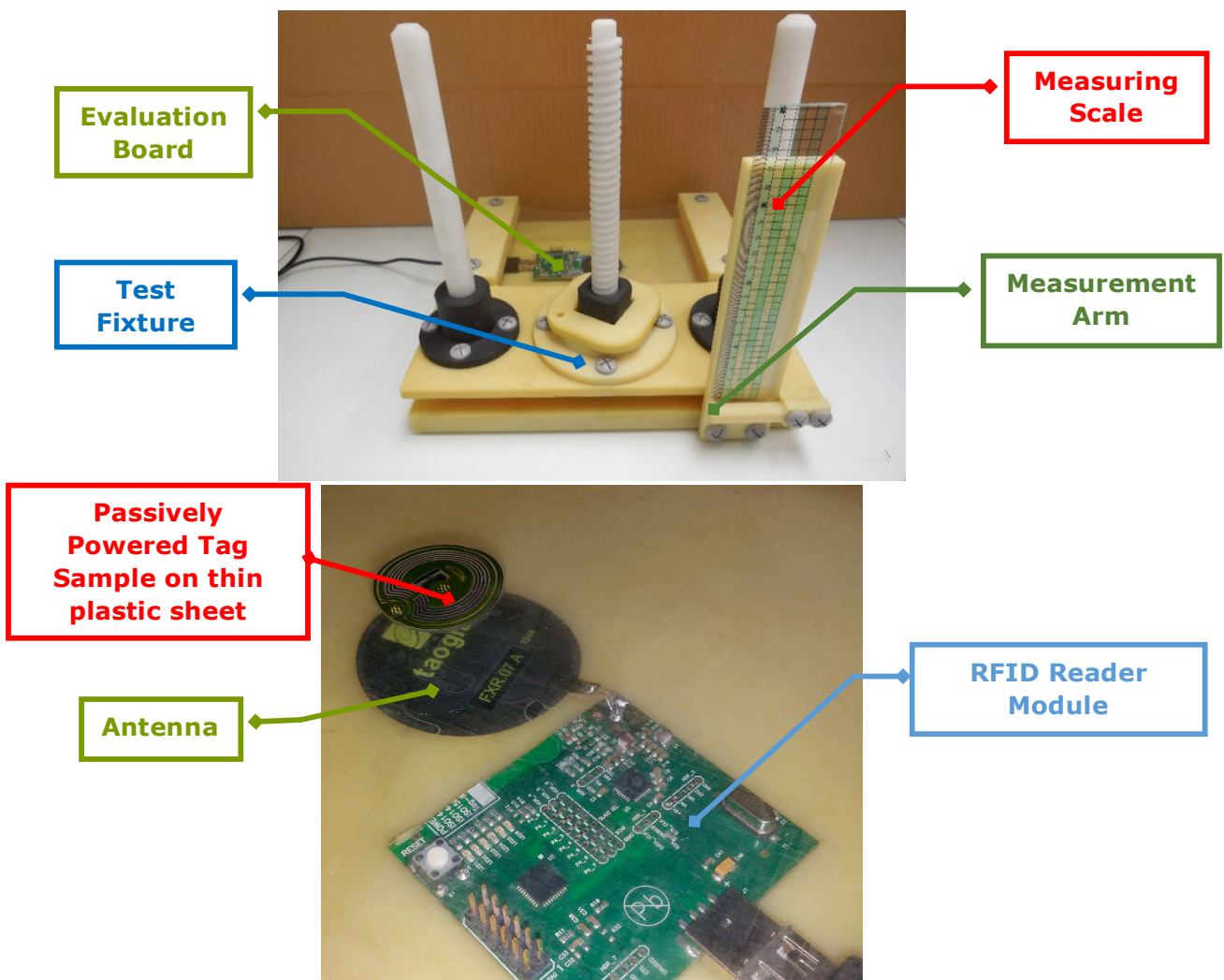

The test sample is placed on a thin sheet of plastic connected to the movable part of the fixture. Then the distance is carefully adjusted until the reader can no longer read the sample, thus the maximum interrogation distance is displayed in the ruler.

3.2. RFID tags used for test

A total of 7 RFID tags were used to measure the interrogation distances. The next picture shows type 1 and type 2 respectively.

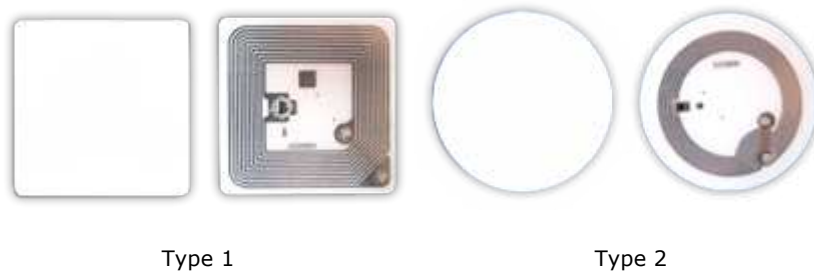

Type 1 tag is based on ISO/IEC 14443A standard and has 512 bytes of memory. Type 2 tag is based on ISO/IEC 14443A standard and has 192 bytes of memory.

The next picture shows the Tag-it HF-I RFID tags from Texas Instruments: RI-102-112, RI-I11-112, RI-I03-112, RI-I16-112, button type, and RI-I17-112.

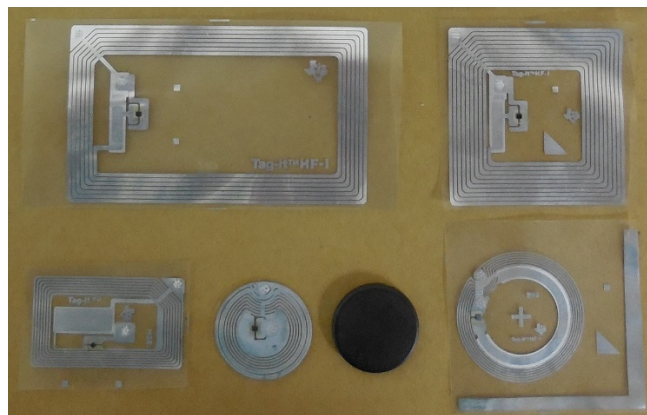

The Tag-it HF-I Plus Transponder Inlay family of Texas Instruments RFID is based on the ISO/IEC 15693 standard for contactless integrated circuit cards (vicinity cards) and ISO/IEC 18000-3 standard for item management.

3.3. Matching

The interrogation distances presented here were taken with the antenna connected directly to the evaluation boards with the default matching circuit. This is not necessarily the optimal matching circuit that could be designed for a particular antenna. We kept the default matching of each evaluation board to minimize the number of variables in testing and keep integration as simple as possible.

As with any matching network the exact circuit and values for an optimal network depend on the combination of antenna, NFC circuit, any intervening transmission line and the environment presented to the antenna. These factors are specific to the particular end product.

As a starting point, to achieve the read range results presented here, use the matching network detailed in the schematic of the evaluation board for your particular NFC chip and keep the antenna free of any obstruction. Once you can demonstrate successful reads you can then optimize performance as desired.

If the matching network is required, you should implement the following topology:

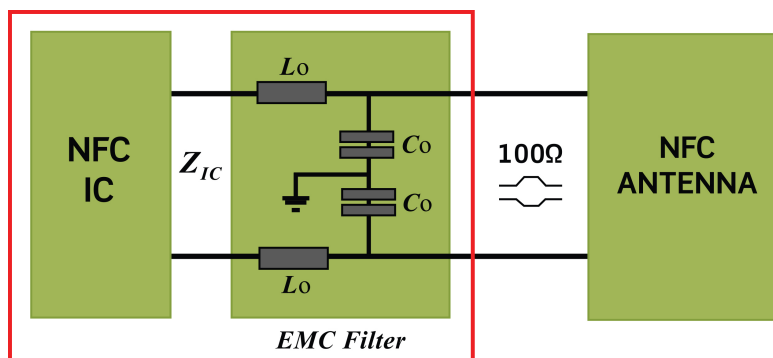

The matching circuit should be designed to match the IC impedance Z_{IC} to 100Ω and then connect the antenna through a 100Ω differential pair.

3.4. Test results

A total of 7 sample devices were used to measure the interrogation distances in two scenarios, over plastic and over metal, using the Texas Instruments TRF7970AEVM evaluation board. The results are:

- Over plastic:

RFID Tag	Dimensions (mm)	Interrogation Distance (mm)
Topaz512 (Type 1)	43 x 43	13
NTAG203 (Type 2)	Φ 42	16
Tag-it HFI Plus RI-I11-112	45 x 45	23
Tag-it HFI Plus RI-I02-112	76 x 48	22
Tag-it HFI Plus RI-I03-112	38 x 22.5	13
Tag-it HFI Plus RI-I16-112	Φ 24.2	14
Tag-it HFI Plus RI-I17-112	Φ 32.5	16

- Over metal:

RFID Tag	Dimensions (mm)	Interrogation Distance (mm)
Topaz512 (Type 1)	43 x 43	10
NTAG203 (Type 2)	Φ 42	15
Tag-it HFI Plus RI-I11-112	45 x 45	18
Tag-it HFI Plus RI-I02-112	76 x 48	19
Tag-it HFI Plus RI-I03-112	38 x 22.5	10
Tag-it HFI Plus RI-I16-112	Φ 24.2	12
Tag-it HFI Plus RI-I17-112	Φ 32.5	14

4. Mechanical Drawing (unit:mm)

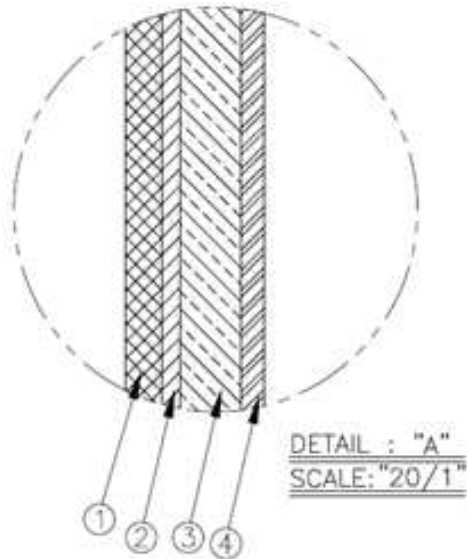

	Name	P/N	Material	Finish	QTY
1	FXR.07.A FPCB 50.36x45.5	1001120000033A	Polymer	Black	1
2	Double Sided Adhesive	1001120000033A	3M467	Natural	1
3	FXR.07.A.dg Flux Director	001015C050000A	Ferrite	Natural	1
4	Adhesive Tape	001015C050000A	Adhesive Tape	Natural	1

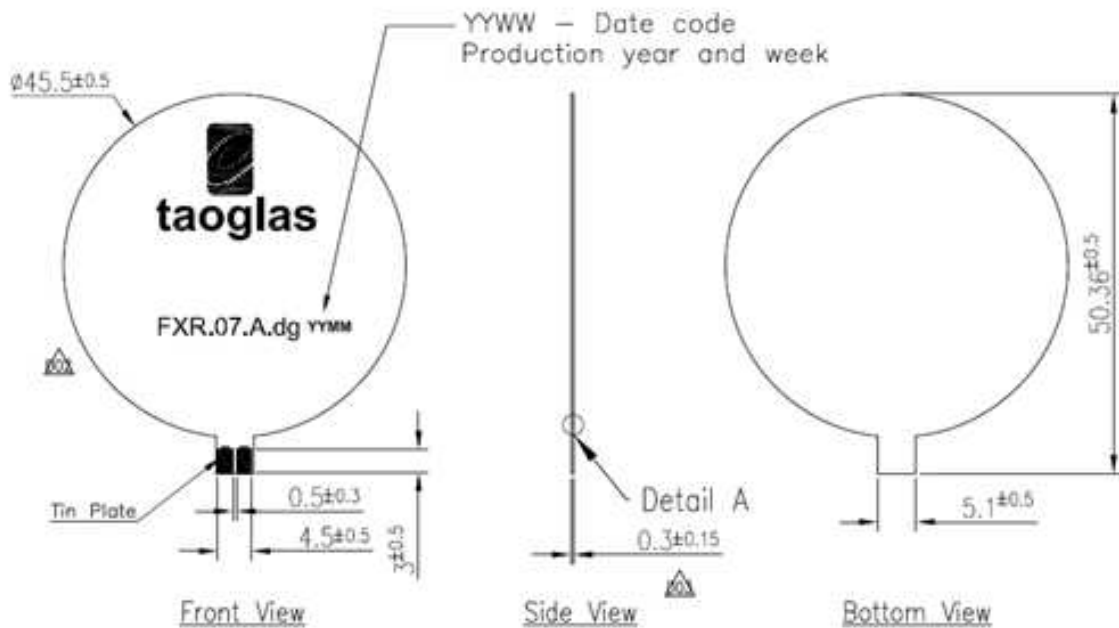

5. Packaging

FXR.07.A.dg

Packaging Specifications

100pcs FXR.07.A.dg per PE Bag
 Bag Dimensions - 187 x 137mm
 Weight - 146g

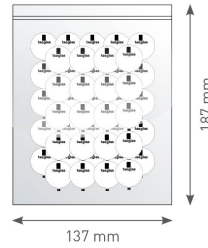

1000pcs FXR.07.A.dg per PE Large Bag
 Bag Dimensions - 470 x 380mm
 Weight - 1.46Kg

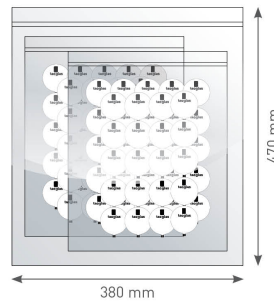

Carton Qty - 5,000 FXR.07.A.dg
 Carton - 330 x 260 x 240mm
 Weight - 7.8Kg

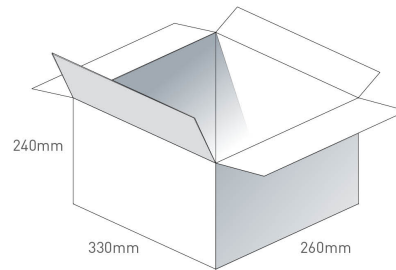

Pallet Dimensions 1200 x 1000 x 1350mm
 60 Cartons per Pallet
 12 Cartons per layer
 5 Layers

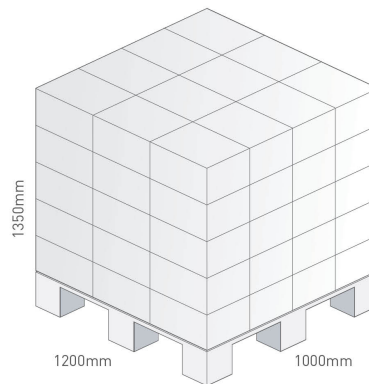



Taoglas makes no warranties based on the accuracy or completeness of the contents of this document and reserves the right to make changes to specifications and product descriptions at any time without notice. Taoglas reserves all rights to this document and the information contained herein.

Reproduction, use or disclosure to third parties without express permission is strictly prohibited.

Copyright © Taoglas Ltd.