



Chipsmall Limited consists of a professional team with an average of over 10 year of expertise in the distribution of electronic components. Based in Hongkong, we have already established firm and mutual-benefit business relationships with customers from,Europe,America and south Asia,supplying obsolete and hard-to-find components to meet their specific needs.

With the principle of “Quality Parts,Customers Priority,Honest Operation,and Considerate Service”,our business mainly focus on the distribution of electronic components. Line cards we deal with include Microchip,ALPS,ROHM,Xilinx,Pulse,ON,Everlight and Freescale. Main products comprise IC,Modules,Potentiometer,IC Socket,Relay,Connector.Our parts cover such applications as commercial,industrial, and automotives areas.

We are looking forward to setting up business relationship with you and hope to provide you with the best service and solution. Let us make a better world for our industry!



Contact us

Tel: +86-755-8981 8866 Fax: +86-755-8427 6832

Email & Skype: info@chipsmall.com Web: www.chipsmall.com

Address: A1208, Overseas Decoration Building, #122 Zhenhua RD., Futian, Shenzhen, China





REVISIONS				
DRAWN	REV	DESCRIPTION	DATE	APPROVED
DS	00	ORIGINAL	11-7-01	MM
KP/TC	01	UPDATED FORMAT, NOTES, TOLERANCES, ADDED WEIGHT, CAVITY LOCATION, MISSING DIMS AND -X TO NAMING CONVENTION.	9-8-11	MS

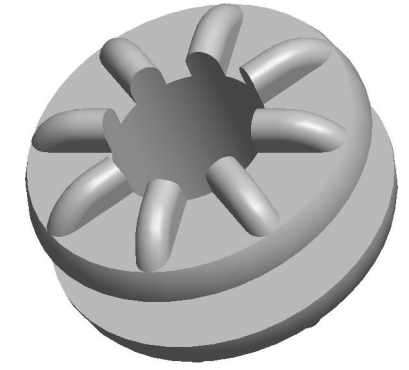
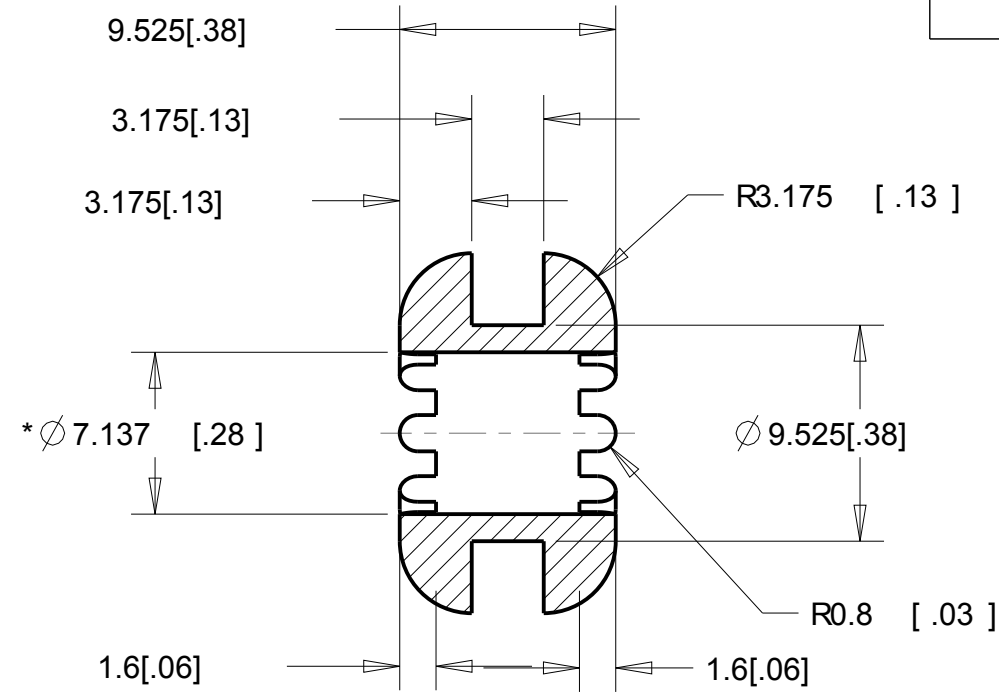
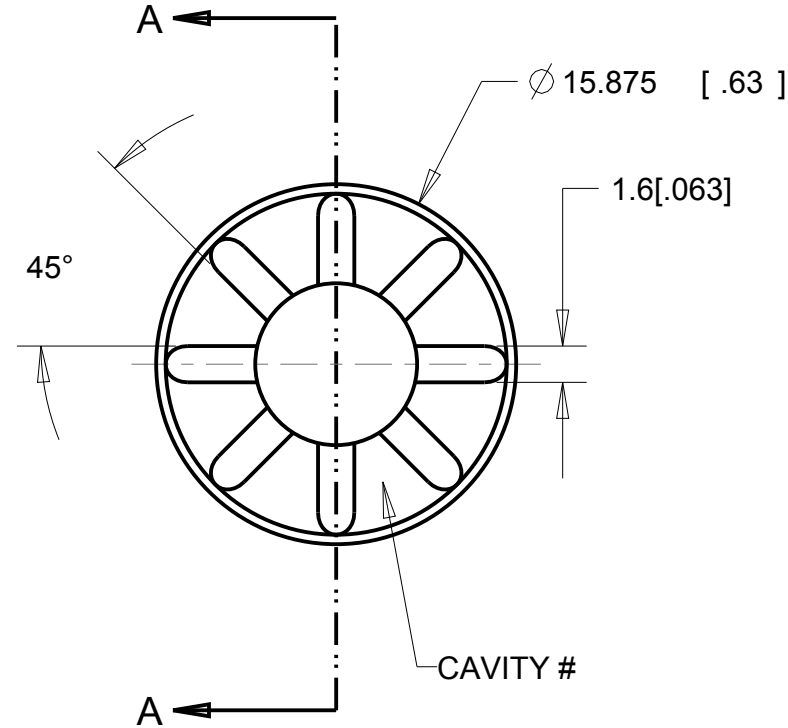

SECTION A-A

GROMMET MATERIAL	SEE PAGE
ISODAMP	1
VERSADAMP	1
ISOLOSS	2

G-404-C8012	C-8012
G-404-C8002	C-8002
G-404-C8001	C-8001
G-404-V2325	V-2325
G-404-3	C-1100
G-404-2	C-1105
G-404-1	C-1002
PART NUMBER	MATERIAL

RANGE	TOL
0 < D ≤ 2 [.079]	± 0.15 [.006]
2 [.079] < D ≤ 25 [.984]	± 0.25 [.010]
25 [.984] < D ≤ 50 [1.969]	± 0.4 [.016]
50 [1.969] < D	± 0.6 [.024]

5. FOR ISOLOSS MATERIAL, USE THE TOLERANCE TABLE ON PAGE 2
4. FOR VERSADAMP AND ISODAMP MATERIAL, USE THE TOLERANCE TABLE ON PAGE 1
3. MAX DRAFT ALLOWED: 2°
2. CRITICAL DIMENSIONS SHALL HAVE C_{pk} VALUE ≥ 1.33 WITH ONGOING SPC DATA REQUIRED
1. CRITICAL DIMENSIONS ARE MARKED WITH "***".

NOTES:

UNLESS OTHERWISE SPECIFIED UNITS ARE: MM [IN] TOLERANCES ARE IN THE TABLE TO THE LEFT: ANGLES ±1.0 °	MATERIAL: SEE TABLE ON LEFT	AEARO TECHNOLOGIES LLC * a 3M company		
	QUALITY CONTROL: MUST COMPLY WITH AEARO TECHONLOGIES LLC SUPPLIER QUALITY MANUAL REQUIREMENTS	TITLE GROMMET - NON INTERNALLY RIBBED		
ALLOWABLE FLASH: 0.12 MM [.005]	GATE: ±0.15MM [.006] CALC WT 0.89 GRAM REF	NOTES: ANY FEATURE NOT DIMENSIONED IN PRINT MUST BE VISIBLY PRESENT, UTILIZE 3D CAD FOR CREATION	SIZE B	ITEM CODE
			DWG NO. G-404-X PAGE 1 OF 2	

1

2

3

4

REVISIONS



D

D

C

C

B

B

A

A

G-404-SL60300	SL-60300
G-404-SL50300	SL-50300
G-404-SL35300	SL-35300
G-404-SL20300	SL-20300
PART NUMBER	MATERIAL

RANGE	TOL
0<D=<10 [.394]	± 0.15 [.006]
10 [.394]<D=<20 [.787]	± 0.2 [.008]
20 [.787]<D=<50 [1.969]	± 0.25 [.010]
50 [1.969]<D=<80 [3.150]	± 0.35 [.014]
80 [3.150]<D	±0.5%

UNLESS OTHERWISE SPECIFIED UNITS ARE: MM [IN] TOLERANCES ARE IN THE TABLE TO THE LEFT: ANGLES ±1.0 °
ALLOWABLE FLASH: 0.3 MM [0.012]
GATE:
CALC WT 0.75 GRAM REF

MATERIAL: SEE TABLE ON LEFT
QUALITY CONTROL: MUST COMPLY WITH AEARO TECHONOLGIES LLC SUPPLIER QUALITY MANUAL REQUIREMENTS
NOTES: ANY FEATURE NOT DIMENSIONED IN PRINT MUST BE VISIBLY PRESENT, UTILIZE 3D CAD FOR CREATION

AEARO TECHNOLOGIES LLC * a 3M company		
TITLE GROMMET - NON INTERNALLY RIBBED		
SIZE B	ITEM CODE	DWG NO. G-404-X PAGE 2 OF 2

1

2

3

4