



Chipsmall Limited consists of a professional team with an average of over 10 year of expertise in the distribution of electronic components. Based in Hongkong, we have already established firm and mutual-benefit business relationships with customers from,Europe,America and south Asia,supplying obsolete and hard-to-find components to meet their specific needs.

With the principle of “Quality Parts,Customers Priority,Honest Operation,and Considerate Service”,our business mainly focus on the distribution of electronic components. Line cards we deal with include Microchip,ALPS,ROHM,Xilinx,Pulse,ON,Everlight and Freescale. Main products comprise IC,Modules,Potentiometer,IC Socket,Relay,Connector.Our parts cover such applications as commercial,industrial, and automotives areas.

We are looking forward to setting up business relationship with you and hope to provide you with the best service and solution. Let us make a better world for our industry!



Contact us

Tel: +86-755-8981 8866 Fax: +86-755-8427 6832

Email & Skype: info@chipsmall.com Web: www.chipsmall.com

Address: A1208, Overseas Decoration Building, #122 Zhenhua RD., Futian, Shenzhen, China





金龙机电股份有限公司

JINLONG MACHINERY & ELECTRONICS

www.jinlong-machinery.com

sales@jinlong-machinery.com

PRODUCT SPECIFICATION

客户信息	客户名称/Customer	
	客户代码/Part No.	
	客户确认签章 /Customer Approved Signatures	

K O T L	文件编号/Spec No.	KOTL-G-B011		
	品名描述/ Product Description	扁平振动马达 Z Axis LRA Coin type vibration motor		
	型号/Part No.	G0832012		
	送样日期/Date			
	设计/Designed by	审核/Checked by	批准/Approved by	
	杨兰/YANG LAN	黄浦/HUANG PU	黄剑辉/HUANG JH	
	2017.08.25	2017.08.25	2017.08.25	

规格书目录
Specification Content

No.	规格书内容/Specification	页码/Page
0	目录/Contents	1
1	修订履历/Change Records	2
2	适用范围/Applicable scope/使用条件/Applicable Conditions	3
3	性能标准/ characteristics Standard	4/5
4	机械性能/Mechanical characteristics	6
5	测定方法/ Determination Condition	7
6	可靠性实验/Reliability Test	8
7	可靠性实验/Reliability Test/判断特性/Requirements after the test	8/9
8	使用注意事项/Attention	10
9	包装/Packaging	11
10	马达外形图/Vibra outline drawing	12

1. 适用范围/Applicable scope

本规格书适用于线性振动马达 G0832012 系列。

This specification applies to linear type motor G0832012 series.

2. 使用条件/Applicable conditions

项目/Item		规格/Specification
2-1	额定电压/Rated Voltage	1.8VrmsAC, Sine wave
2-2	使用电压范围/Operating Voltage	0.1~1.8VrmsAC
2-3	振动方向/Direction of vibration	Z axis
2-4	使用环境/Operating Environment	-20℃~+60℃, Ordinary Humidity:65±20%RH
2-5	输入频率/Input Frequency	235 Hz
2-6	保存条件/Storage Conditions	-30℃~+70℃, Ordinary Humidity:65±20%RH

3. 测定条件/Masurement Conditions

一般情况下，马达可以在 22~28℃，相对湿度 45~85%RH 的环境中测试。为保证一致性，测试应在下表规定内进行。Normally, the vibra could be measured under 22~28℃, 45~85%RH. For coherence, it must be measured under below environment requirements:

项目/Item		规格/Specification
3-1	温度/Temperature	25℃±3℃
3-2	湿度/Humidity	65±20%RH
3-3	气压/Air Pressure	1011±40 hpa

4、性能标准/ characteristics Standard

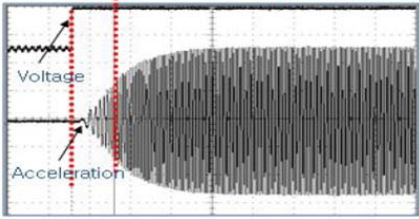
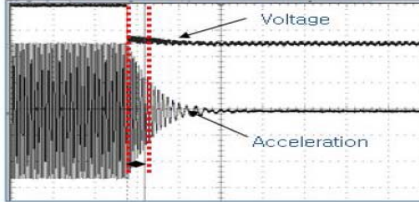
	项目/Item	规格/Specification	测试条件/Test Condition
4-1	额定电压/ Rated Voltage	1.8VrmsAC, Sine wave	1.8VrmsAC, Sine wave
4-2	额定频率 Rated Frequency	235 Hz	235Hz, 1.8VrmsAC, sine wave Refer to Figure 2
4-3	Rated Current 额定电流	Max 80mArms	
4-4	Acceleration F0 点振动量	1.0 Grms Min	
4-5	Acceleration Low temperature operating F0 低温振动量	1.0Grms Min.	-20℃,235Hz,1.8VrmsAC, sine wave
4-6	Frequency Characteristics 频率特性	235±5Hz Refer to Figure 1 参照图形 1	
4-7	Rise Time 上升时间	Max 50msec 时间达到最大振动的 50% ◆ Rising Time [msec] – 50% 	235Hz,1.8VrmsAC, sine wave
4-8	Falling Time 下降时间	Max 80msec 断电后时间达到最大振动的 50% ◆ Falling Time [msec] – 50% 	235Hz,1.8VrmsAC, sine wave
4-9	绝缘电阻 Insulation Resistance	10MΩ Min (100V)	在 100V 直流电压下机壳与导线 /At DC 100V Between wire and case
4-10	阻抗 Resistance	22.0±4.0 Ohm	25℃ ± 3℃

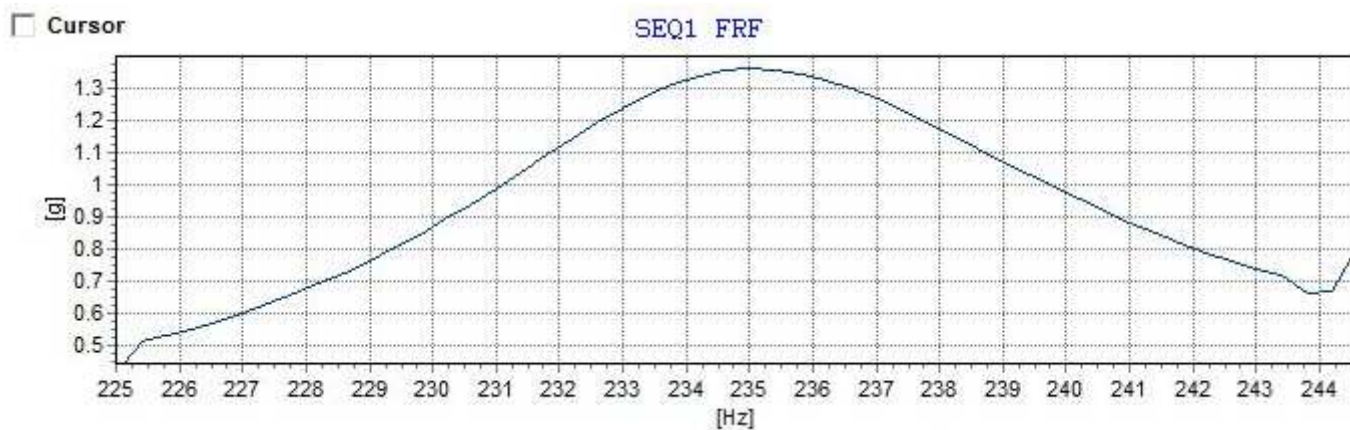
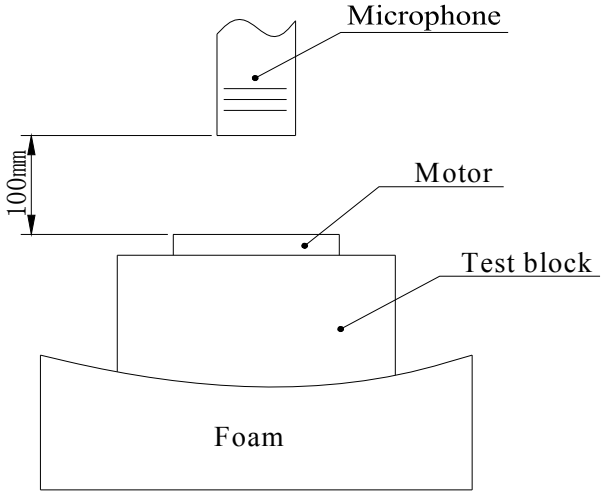

Figure 1. Linear Vibrator Frequency Characteristics/频率特性

5、机械性能/Mechanical characteristics

项目/Item		规格/Specification	测试条件/Test Conditions
5-1	噪音/Noise	50分贝最大/50 dB Max. (10cm distance from microphone/ 距离麦克风 10 cm 的位置)	<p>235Hz, 1.8VrmsAC, sinewave) 背景噪音: 不大于28dB. A计权. Back ground noise 28dB (A) Max.</p>  <p>The diagram illustrates the noise test setup. A microphone is positioned 100mm above a motor, which is mounted on a test block. The test block is placed on a foam base.</p>
5-2	马达尺寸 Vibra Size	Φ8*3.25	Slide calipers
5-3	原子线抗拉强度 Anti-pulling strength of atomic line	最小 5N/5N(0.5kgf) Min	破坏性测试, 对原子线沿着轴向施加推力 Destructive test, give pulling force to the atomic line along to the axial direction.

6、测试方法/Test Method

测试系统/test system

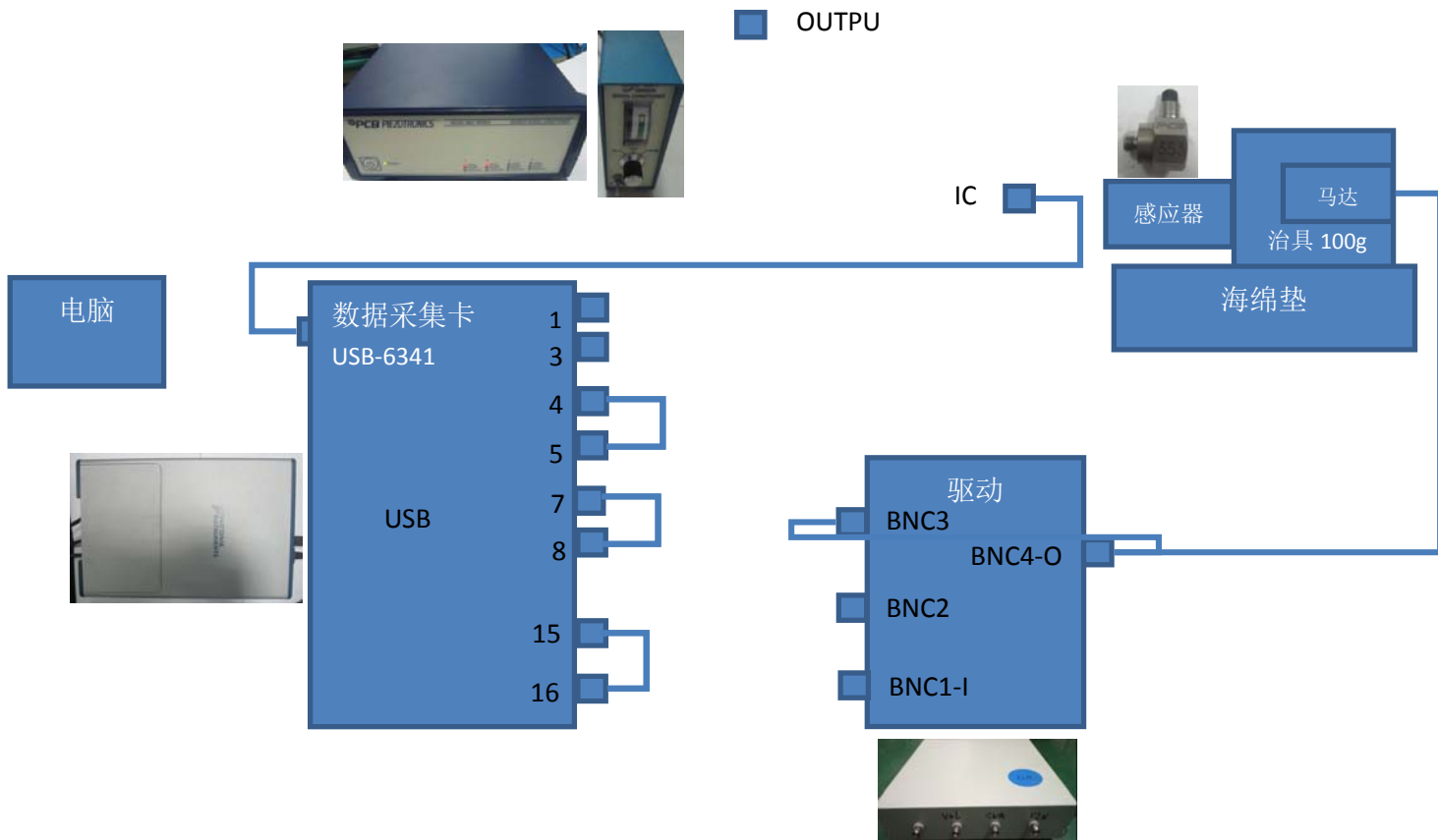

测试治具/test fixture

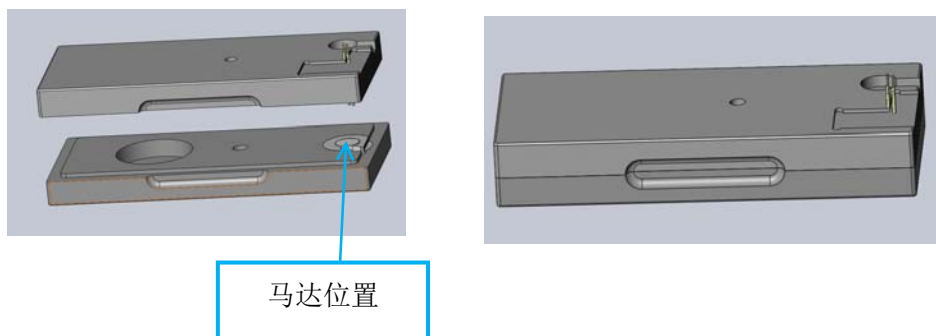

测试界面/test interface

Test Item	Test Value	Lower Limit	Upper Limit
[SEQ1] F0 Frequency	235.0	230.00	240.00
[SEQ2] F0 Current	75.9	----	80.00
[SEQ2] F0 Vibration	1.33	1.00	1.50
[SEQ4] RisingTime	25.8	----	50.00
[SEQ4] FallingTime	27.9	----	80.00

7、耐久性能/Durability characteristics

项目/Item		测试条件/Test Condition	判定标准/Judgment
7-1	寿命 Lifetime test	1、试验循环/Test cycle:500,000 cycle (1cycle: 2sec on/1sec off) 2、测试设备/Test equipment: 寿命试验机 /Lifetime test machine. 3. 输入电压(1.8VrmsAC, Sine wave),输入频率: 235HZ Input voltage : 1.8VrmsAC,Sine -wave), Input frequency(235Hz)	试验后, 马达应符合 7-1 项的要求/ The test result should meet the requirements of item 7-1.
7-2	低温放置 Low temperature storage test	温度/Temperature:-40±2℃ 时间/Time :96H	在常温下放置 4 小时后, 马达应符合 7-2 项要求/ After 4-hour storage, the test result should meet the requirements of item 7-2.
7-3	高温放置 High temperature storage test	温度/Temperature:80±2℃ 时间/Time :96H	
7-4	湿度放置 Humidity storage test	温度/Temperature:55±2℃ 湿度/Humidity:95%RH 时间/Time:96H 无水气凝结/No condensation of moisture	
7-5	振动/Vibration test	1. 马达固定治具重量 180g The motor fixed fixture weight 180g 2. 全振幅/Double amplitude:1.5mm(p-p) 3. 频率/Frequency:10~55Hz 4. 加速度/Acceleration:22m/s 5. 周期/Period:10min 范围内 (10~55~10Hz) /10Minutes log sweep(10~55~10Hz) 6. 条件/Condition:在样机中, 在 3 个直的轴方向每个方向做 1H 测试/ Do the test at three straight shaft directions for ten minutes to the samples.	测试结果应符合 7-2 项要求/ The test result should meet the requirements of item 7-2.
7-6	自然跌落/Drop test	1. 试验状态/Test status:将马达固定在重量约 180g (包括马达本身) 的物体上, 落向水泥地面/Fix the motor on a object weighted about 180g (include the motor) and drop it to the cement floor. 2. 高度/Height:1.5m 3. 方向/Dirrection : ±X, ±Y, ±Z 4. 次数/ Number of the test:每个方向 3 次/ times for each direction	测试结果应符合 7-2 项的要求/ The test result should meet the requirements of item 7-2.

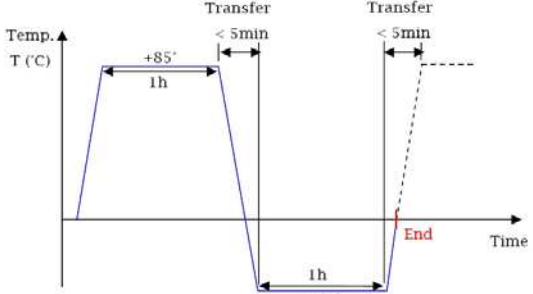
7-7	温度冲击试验 Temperature shock test	<p>5. 测试模式/Test mode: 1 hour at -40°C, 1 hour at 85°C, as one cycle, Transfer time between extreme temperatures: <5 分钟</p> <p>8. /5min 循环次数: 15cycles</p> 	<p>在常温下放置 2 小时后，测试结果应符合 7-2 项要求/ After 2 hour exposure in ordinary temperature and humidity and the test result should meet the requirements of item 7-2.</p>
-----	----------------------------------	---	---

8、判断特性/Requirements after reliable test

8-1 试验后应满足下列条件

- 变化率：不超出初始值的±30%
- 额定电流：80 mArms Max.
- 噪音：50dBMax

8-2 外观、结构方面无异常发生

8-1 After test, following specifications must be satisfied.

- Acceleration: Initial Value±30%
- Rated Current: 80mArms Max
- Noise_T:50dBMax

8-2 There should be no abnormalities to happen in structure.

9、使用注意事项/ Points for Attentions

9-1.必须安装规格书标准使用，否则性能与寿命都将受到相当的减少，必须注意电压的使用范畴。

Make sure to use the motor in accordance with the specifications, if not, the lifetime might be reduced accordingly, pay high attention to the range of the voltage.

9-2.建议马达在 6 个月内使用,不要在以下环境中使用及保存.

9-2-1.高温与高湿的场所;

9-2-2.腐蚀性气体，如：H₂S,SO₂,NO₂,CL₂;

9-2-3.生锈场所。

The motor is suggested using within 6 months. Do not use or store the motor under below environments:

9-2-1.High temperature and high humidity area;

9-2-2.Corrosive gas such as H₂S,SO₂,NO₂,CL₂;

9-2-3.Dusty area;

9-3.注意处理马达的工作环境，避免含铁质物体被马达吸住，否则马达将会产生噪音，性能会降低，从而降低产品的可靠性。

Pay attention to the working environment of the motor, avoid any iron material sucked by the motor, or the motor might cause noise and the performance will be degraded, meanwhile, the reliability might be reduced.

9-4.应确信本产品不会违背相关的标准，以及法律法规与行政令。

Make sure the product will not violate any local relevant standards, as well as laws and regulations.

9-5.拿马达时，要轻拿轻放。

Handle with care.

9-6.钢板面边缘有少许锈斑是允许的。

A little rusty spot at the steel plate surface is allowed.

9-7.我司遵循持续发展的策略，在不预先通知的情况下，有对产品（部品）进行修改和改进的权利，当然这些都不会影响马达的特性及使用功能。

Our company follow the sustainable developing strategy, and have the right to make change and improvements to our product without giving notice in advance . of course ,these changes and improvements will not affect the characteristics and function of the motor.

10、包装/Packing

见附件

11、外形图/ Outline drawing

见附件

扁平系列马达包装
Pack drawing of coin type

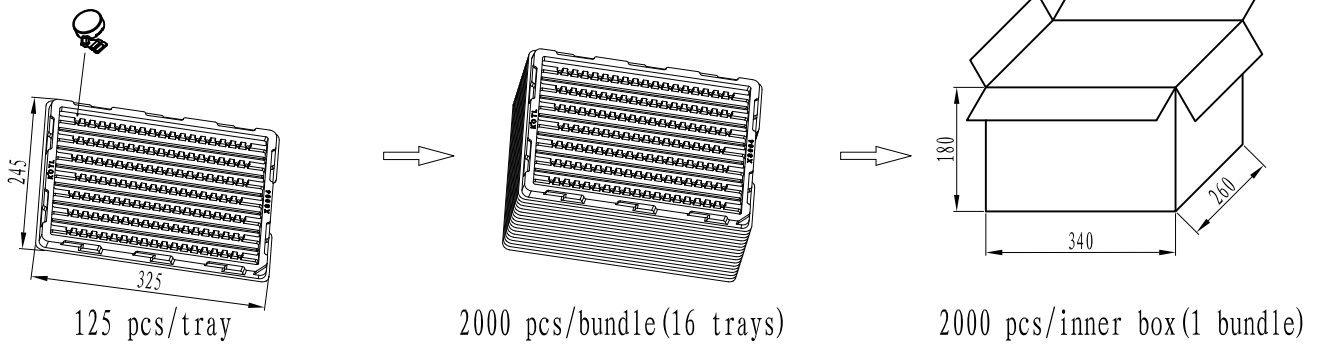

Remarks:

4000pcs/CNT: 53cm × 35cm × 20cm

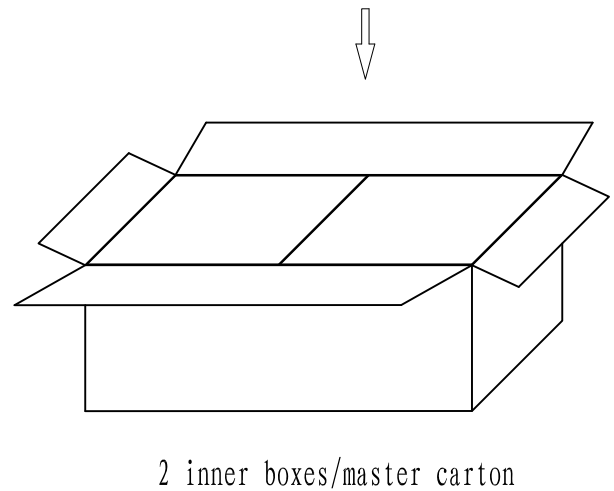

包装试验要求:

沿外包装箱 $\pm x$, $\pm y$ 和 $\pm z$ 方向, 距水泥地面 1.5m 高度, 各自由跌落 2 次, 马达应无机械损伤, 电气性能仍符合标准要求。

Drop Test with carton:

Drop the carton in the axial directions of $\pm x$, $\pm y$, $\pm z$ onto the concrete floor from 1.5m height, drop twice each direction. After drop test, no mechanical damage to motors, and the electrical performances remain unchanged

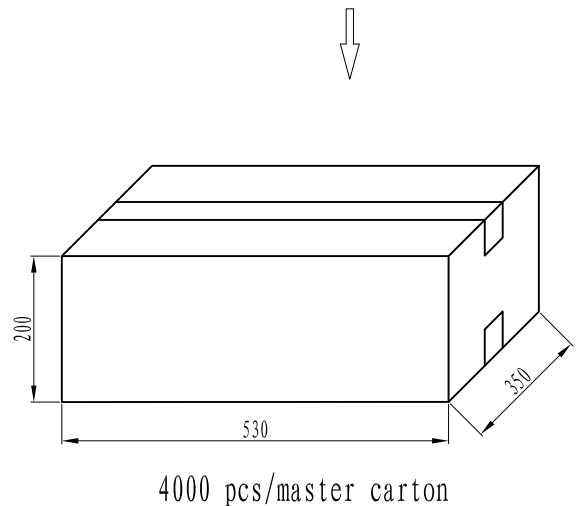

金龙机电股份有限公司
技术开发部

Design Department JinLong
Machinery & Electronics Co., Ltd

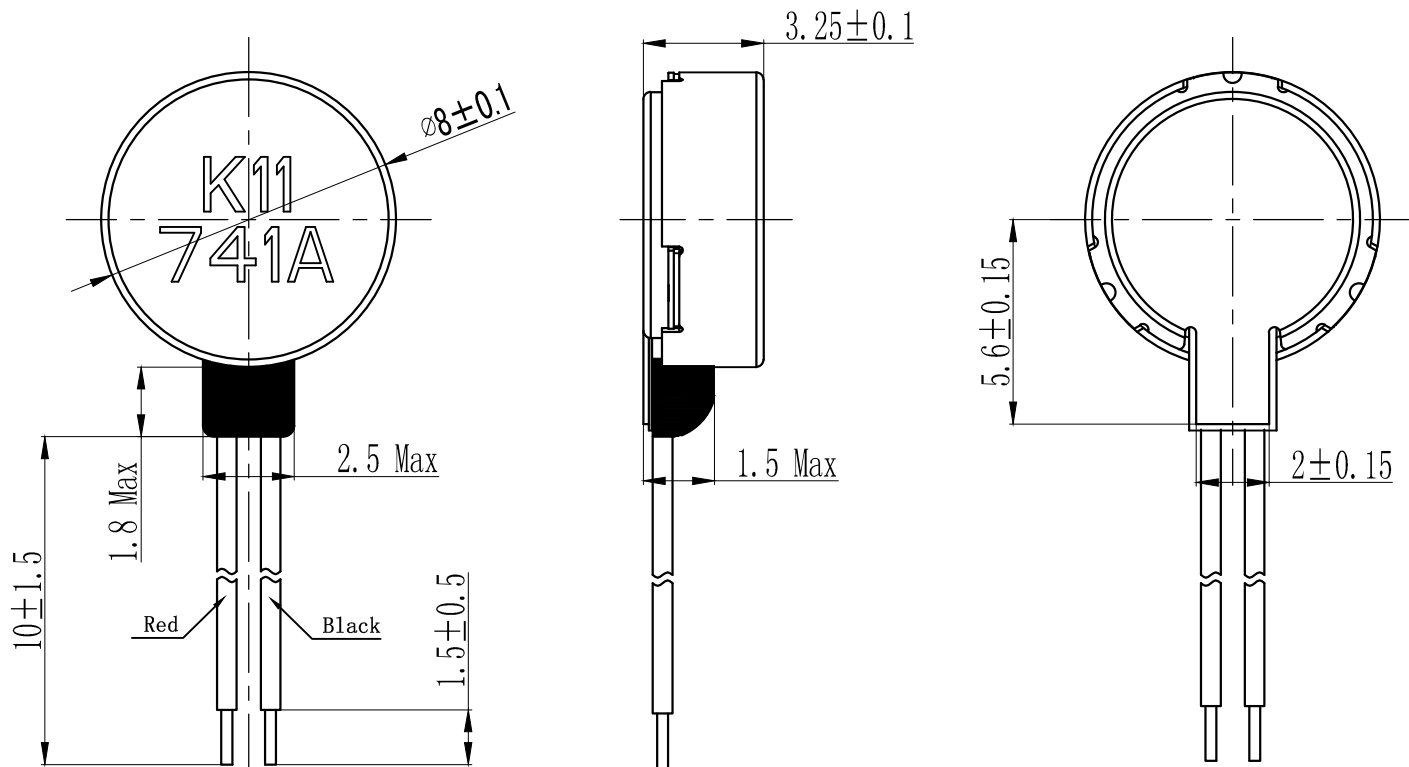

技术要求

1. 额定电压/Rated Input Voltage:1.8Vrms AC Sinewave
2. 额定频率/Rated Frequency:235±5 Hz;
3. 使用电压范围/Operating Voltage:0.1-1.8V AC;
4. 额定电流/Rated Current:80mA Max:
5. FO点振动量/Acceleration:1.0 Grms Min:
6. 电阻/Resistance:22±4Ω;
7. 上升时间达到最大振动的50%/Rise time reaches the maximum vibration of 50%: 50msec Max
8. 断电后, 下降时间达到最大振动的50% After power,Fall time reaches the maximum vibration of 50%: 80msec Max
9. 在100V直流电下, 导线与机壳间绝缘电阻 $\geq 10M\Omega$ /At DC 100V, thatlead wire and case thin out the insulation resistance: $\geq 10M\Omega$.
10. 导线规格/Lead wire spec:AWG32 UL3302.
11. 符合金龙机电股份有限公司最新版《禁用有害物质标准》.

借(通)用
件登记

旧底图总号

底图总号

签字

日期

档案员 日期

标记	处数	更改内容	签字	日期
设计			标准化	
制图			审定	
校对			批准	
工艺			日期	

jinlong-machinery.com

图样标记

版次

比例

S

S / 0

1:1

共 1 张

第 1 张

金龙机电股份有限公司

检测外形图

03.10.G0832.012