



Chipsmall Limited consists of a professional team with an average of over 10 year of expertise in the distribution of electronic components. Based in Hongkong, we have already established firm and mutual-benefit business relationships with customers from,Europe,America and south Asia,supplying obsolete and hard-to-find components to meet their specific needs.

With the principle of "Quality Parts,Customers Priority,Honest Operation,and Considerate Service",our business mainly focus on the distribution of electronic components. Line cards we deal with include Microchip,ALPS,ROHM,Xilinx,Pulse,ON,Everlight and Freescale. Main products comprise IC,Modules,Potentiometer,IC Socket,Relay,Connector.Our parts cover such applications as commercial,industrial, and automotives areas.

We are looking forward to setting up business relationship with you and hope to provide you with the best service and solution. Let us make a better world for our industry!



Contact us

Tel: +86-755-8981 8866 Fax: +86-755-8427 6832

Email & Skype: info@chipsmall.com Web: www.chipsmall.com

Address: A1208, Overseas Decoration Building, #122 Zhenhua RD., Futian, Shenzhen, China



G1G170 Series

Combustion Air Blower



Ø 170 mm Impeller

- Housing: aluminum.
- Impeller: sheet aluminum.
- Cover: plastic PP30TV.
- Interfaces page 120.

Part Number	Model Number	VAC	Hertz	Airflow (CFM)*	Power Input (W)*	Speed* (RPM)	Current (A)	Max. Amb. Temp C	Weight (lbs.)
***	G1G170-AB	115 or 230	50/60	362	300/315	5500/5650	4.00/215	70	10.6

* Data based on free delivery conditions. Subject to alterations.

*** Contact application engineering for part number.

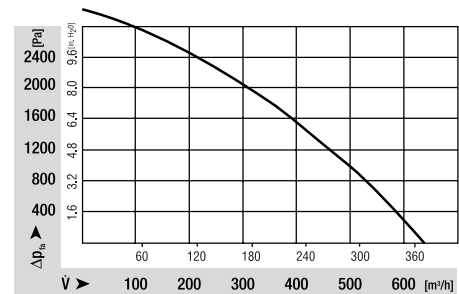
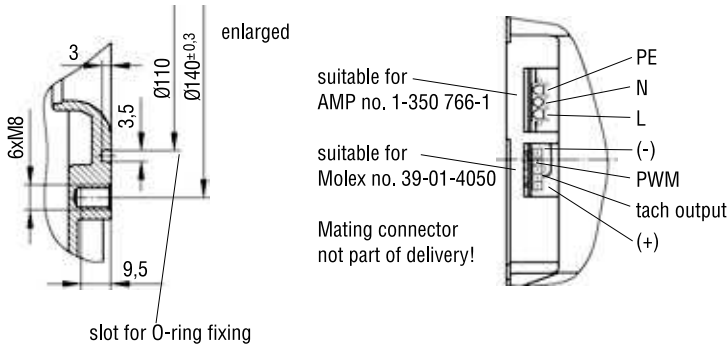
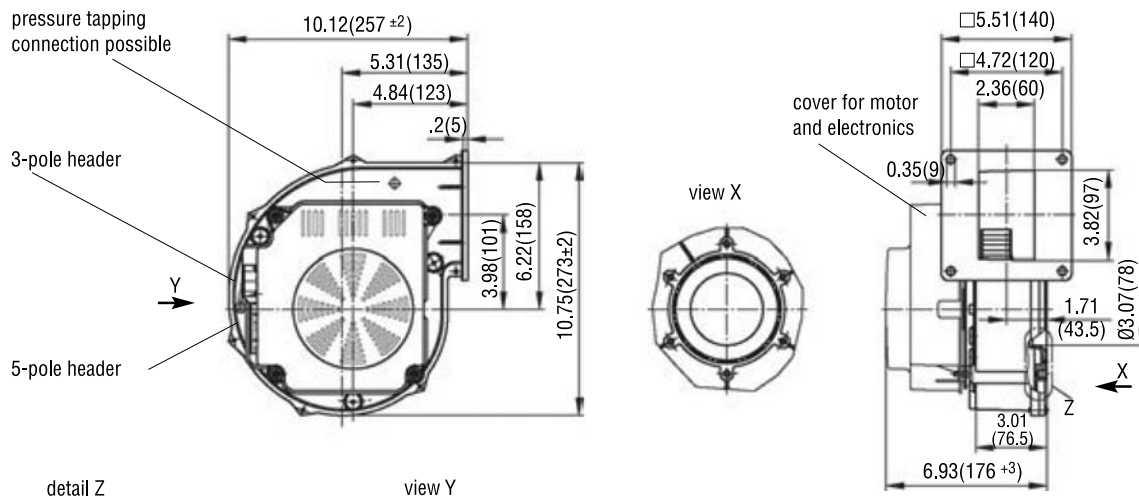

Combustion Air Blowers

Controllable blowers with steep pressure/air flow characteristics curves and high maximum pressure are required to provide optimal fuel/air mixture and volume for modern gas or oil-fired heating boilers that operate in modulating mode, and also for gas technology in every operating status and external condition.

The RG blowers with brushless DC-motors have been developed to meet the special requirements of these appliances. ebm-papst has played a decisive part in the development of EC blowers suited to this purpose and can, today, offer the most extensive range of blowers for this field of application. The special features of these blowers can, however, also be used in a wide range of other applications.

Housing:

RG and G1G/G3G: Die-cast aluminium

The air tightness required for gas pre-mixing is achieved by sealing the two casing shells and the passage hole of the drive shaft. When using blowers for such applications, special criteria, testing and approvals have to be asserted with the customer. Safety tests (gas tightness etc.) for the complete system have to be carried out by the customer and are his responsibility.

Blower impellers:

RG and G1G/G3G:

Material: Plastic, anti-static, resistant to pentane, surface resistance $<10^9$, dynamically fine-balanced.

Drive unit:

Brushless DC-motors with integrated electronics.

Series RG: internal-rotor design

Insulation class F (EN60335-1)

Series G1G/G3G: external-rotor design

Insulation class F (EN60335-1)

The motor is anti-vibration mounted to minimize structure-born noise; rigid mounting with RG100.

Protection type:

IP20 with cover

RG100: IP00

Protection class:

The motors comply with the requirements for protection class III. At rated voltages of over 42 V, therefore, a potential separation is provided for between the voltage supply to the motor and the interface to the control module and, commensurate with the requirements on greater insulation, creepage distances and clearances of 8mm are also provided for. Protection class III then only applies to the signal plug.

The blower complies with protection class I.

Humidity class:

The electronics comply with humidity class "E" according to DIN 40040.

The circuit boards are coated with a protective varnish to safeguard optimal protection in a corrosive environment.

Bearings:

Maintenance-free ball bearings covered on both sides, for the RG100 sintered calotte-sleeve bearings with a lubricant depot. Calculated service life expectation L_{10} 40,000 hours of operation at an ambient temperature of 40°C, horizontal mounting position and typical operating conditions.

Mounting positions:

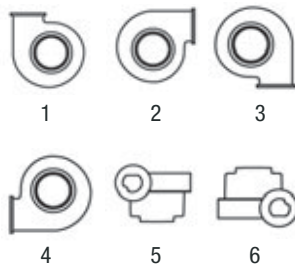

Mounting positions 1 – 4 are possible. If the motor is installed on anti-vibration mounts, the motor weight is given additional support by an elastic element. Details of the mounting position must therefore be provided.

Consultation is indispensable for installation positions 5 and 6.

Pressure relief:

Apertures for pressure relief on request.

Commutation electronics:

Motor electronics integrated in the blower unit, with start-up current limit and reverse battery protection using plug coding, locked-rotor protection and overload protection optional.

See separate drawings for details of interface requirements.

Adaption to the boiler control is required in specific cases.

Speed recognition:

Hall IC signal output (2 pulses per revolution).

RG100: 1 pulse per revolution

The derivative feedback is galvanically decoupled with motors on mains voltage operation.

Closed-/Open-loop speed control:

The blower speed can be adjusted over a wide range using a PWM (pulse width modulation) signal. The PWM signal is a rectangular signal, preferably with constant frequency and variable pulse width. It is activated by an open collector drive and a pull-up resistor.

An additional electronic system is available as an option, to convert an analog voltage signal of 0 – 10 V into the required PWM signal. In addition, there is another electronic system which allows to activate two speeds, preset with potentiometers, via a control input.

Interference suppression/EMC:

230 V AC: EMC according to EN 55011 and EN 50082-2

24 V DC: EMC according to EN 55014