



Chipsmall Limited consists of a professional team with an average of over 10 year of expertise in the distribution of electronic components. Based in Hongkong, we have already established firm and mutual-benefit business relationships with customers from,Europe,America and south Asia,supplying obsolete and hard-to-find components to meet their specific needs.

With the principle of "Quality Parts,Customers Priority,Honest Operation,and Considerate Service",our business mainly focus on the distribution of electronic components. Line cards we deal with include Microchip,ALPS,ROHM,Xilinx,Pulse,ON,Everlight and Freescale. Main products comprise IC,Modules,Potentiometer,IC Socket,Relay,Connector.Our parts cover such applications as commercial,industrial, and automotives areas.

We are looking forward to setting up business relationship with you and hope to provide you with the best service and solution. Let us make a better world for our industry!



Contact us

Tel: +86-755-8981 8866 Fax: +86-755-8427 6832

Email & Skype: info@chipsmall.com Web: www.chipsmall.com

Address: A1208, Overseas Decoration Building, #122 Zhenhua RD., Futian, Shenzhen, China



Part No. G205-8D



Fan Guard for 205mm Fan

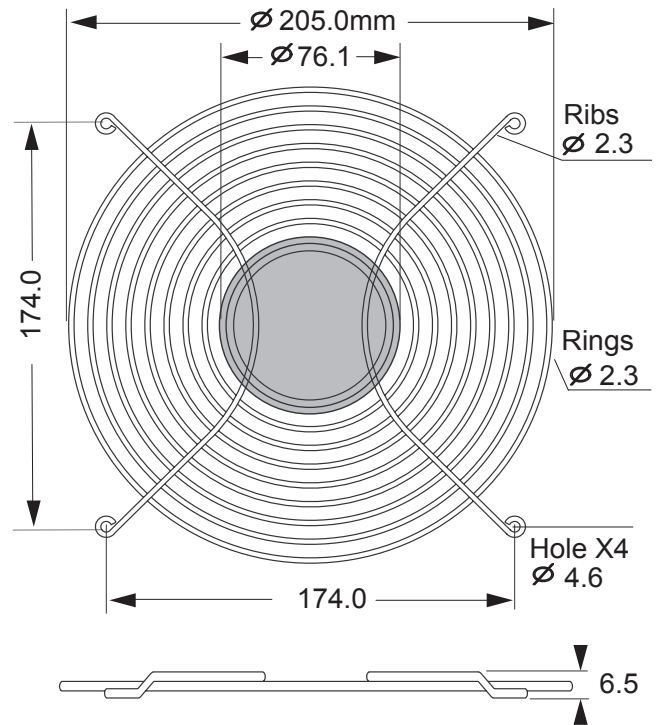
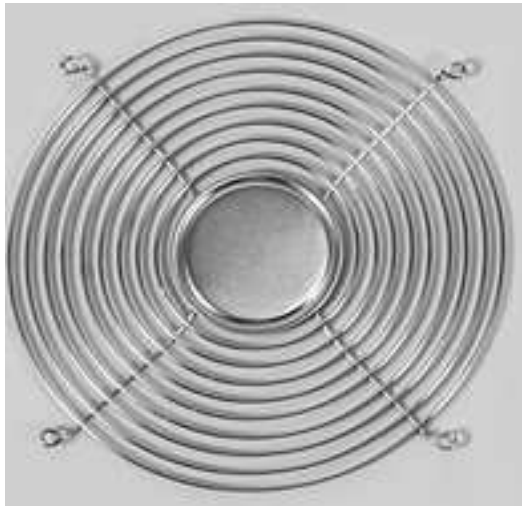

NOTES:

1. MATERIAL:C1008 BRIGHT BASIC WIRE
2. FINISH:BRIGHT NICKEL CHROME
3. RINGS: 2.3MM dia. / RIBS: 2.3MM dia
4. WELDS TO WITHSTAND 88LBS PULL FORCE
5. GENERAL TOLERANCE UNLESS NOTED +/-0.5MM
6. PART MEETS 6.35MM PLUG GAUGE TEST
7. UNIT: MM

Part Number	Description
G205-8D	205mm fan guard, metal

Matching Fan Series

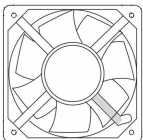

OA205AN

10557 Metric Drive
Dallas, Texas 75243
214-340-0265



OrionFans.com
Information and data is subject to
change without prior notification.