



Chipsmall Limited consists of a professional team with an average of over 10 year of expertise in the distribution of electronic components. Based in Hongkong, we have already established firm and mutual-benefit business relationships with customers from,Europe,America and south Asia,supplying obsolete and hard-to-find components to meet their specific needs.

With the principle of “Quality Parts,Customers Priority,Honest Operation,and Considerate Service”,our business mainly focus on the distribution of electronic components. Line cards we deal with include Microchip,ALPS,ROHM,Xilinx,Pulse,ON,Everlight and Freescale. Main products comprise IC,Modules,Potentiometer,IC Socket,Relay,Connector.Our parts cover such applications as commercial,industrial, and automotives areas.

We are looking forward to setting up business relationship with you and hope to provide you with the best service and solution. Let us make a better world for our industry!



Contact us

Tel: +86-755-8981 8866 Fax: +86-755-8427 6832

Email & Skype: info@chipsmall.com Web: www.chipsmall.com

Address: A1208, Overseas Decoration Building, #122 Zhenhua RD., Futian, Shenzhen, China



MODEL G304K - KADET OPERATOR INTERFACE WITH TFT DISPLAY



- CONFIGURED USING CRIMSON® 2.0 SOFTWARE
- TWO SERIAL COMMUNICATIONS PORTS (1 RS-232 AND 1 RS-232/422/485)
- UNIT'S CONFIGURATION IS STORED IN NON-VOLATILE FLASH MEMORY
- BRIGHT 4.3-INCH TFT ACTIVE MATRIX 256 COLOR 480 x 272 PIXEL DISPLAY
- THREE FRONT PANEL LED INDICATORS
- NEMA 4/IP65 FRONT PANEL
- POWER UNIT FROM 12-28 VDC
- RESISTIVE ANALOG TOUCHSCREEN



GENERAL DESCRIPTION

The 4.3-inch G3 Kadet was designed for applications in which available mounting space is at a premium. Though diminutive in size, the Kadet boasts a bright TFT display with full 256-color support. With a resolution of 480 x 272, the Kadet's 4.3-inch display has a higher resolution and better image clarity than most 6-inch HMIs.

The G3 Kadet offers two high-speed serial ports in the form of one RS-232 and one RS-232/422/485 ports. This allows the Kadet to simultaneously communicate with devices from different manufacturers, as well as to perform protocol conversion.

The G3 Kadet range of HMIs is programmed with Red Lion's free Crimson 2.0 software. Crimson 2.0 offers easy to use drag and drop communications configuration, while the embedded image library allows the programmer to create intuitive screens and prompts for the operator.

SAFETY SUMMARY

All safety related regulations, local codes and instructions that appear in the manual or on equipment must be observed to ensure personal safety and to prevent damage to either the instrument or equipment connected to it. If equipment is used in a manner not specified by the manufacturer, the protection provided by the equipment may be impaired.

Do not use the controller to directly command motors, valves, or other actuators not equipped with safeguards. To do so can be potentially harmful to persons or equipment in the event of a fault to the unit.

CONTENTS OF PACKAGE

- G304K Operator Interface.
- Hardware packet for mounting unit into panel.
- Terminal block for connecting power.
- Spare fuse.

ORDERING INFORMATION

MODEL NO.	DESCRIPTION	PART NUMBER
G304K	4.3" TFT Operator Interface	G304K000
SFCRM2	Crimson 2.0 ¹	SFCRM200
CBL	USB to RS-232 Adaptor, includes "y" cable (CBLSK000)	CBLUSB23
	Communications Cables and Adaptor ²	CBLxxxx
G3FILM	Protective Film	G3FILM4K
	Fuse	G3FUSE00

¹ Use this part number to purchase the Crimson software on CD with a printed manual and cables for the G3 and Kadet series HMIs. Otherwise, download for free from www.redlion.net.

² Contact your Red Lion distributor or visit our website for selection of adapters and cables.

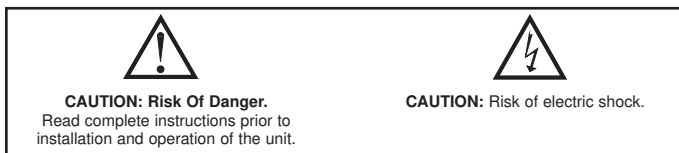

SPECIFICATIONS

1. POWER REQUIREMENTS:

- Must use Class 2 or SELV rated power supply.
- Power connection via removable three position terminal block.
- Supply Voltage: 12-28 VDC, Class 2
- Maximum Power: 3.6 W; Start up current may be as high as 700 mA
- Fused: Fast-blow 800 mA, 5x20 mm

2. LCD DISPLAY:

SIZE	4.3-inch
TYPE	TFT
COLORS	256
PIXELS	480 X 272
BRIGHTNESS	300 cd/m ²
BACKLIGHT TYPE	LED
BACKLIGHT LIFE	50,000 HR TYP.

- 3. **TOUCHSCREEN:** Four-wire resistive analog
- 4. **MEMORY:** 2MB of non-volatile flash memory
- 5. **COMMUNICATIONS:** Two Serial Ports - One RS-232 port, one RS-232/422/485
Serial Ports: Format and Baud Rates for each port are individually software programmable up to 115,200 baud.

6. ENVIRONMENTAL CONDITIONS:

- Operating Temperature Range:** 0 to 45°C
- Operating and Storage Humidity:** 10-90% relative humidity (non-condensing) from 0 to 45°C.
- Vibration:** Operational 10 to 25 Hz in X, Y, Z direction for 30 minutes, 2 g.

7. CERTIFICATIONS AND COMPLIANCES:

- SAFETY**
 UL Listed, File #E302106, UL508, CSA-C22.2 No. 142
 LISTED by Und. Lab. Inc. to U.S. and Canadian safety standards
 UL Type 4 Indoor Use Only Enclosure rating (Face only), UL50
 IP65 Enclosure rating (Face only), IEC 529

ELECTROMAGNETIC COMPATIBILITY

- Consult factory for EMC specifications
- 8. **CONNECTIONS:** Compression cage-clamp terminal block.
 Wire Gage: 12-28 AWG copper wire
 Communications: DB9M connection
- 9. **CONSTRUCTION:** Plastic enclosure with NEMA 4/IP65 front panel when properly installed.
- 10. **WEIGHT:** 9.4 oz (270 g)

DIMENSIONS In inches (mm)

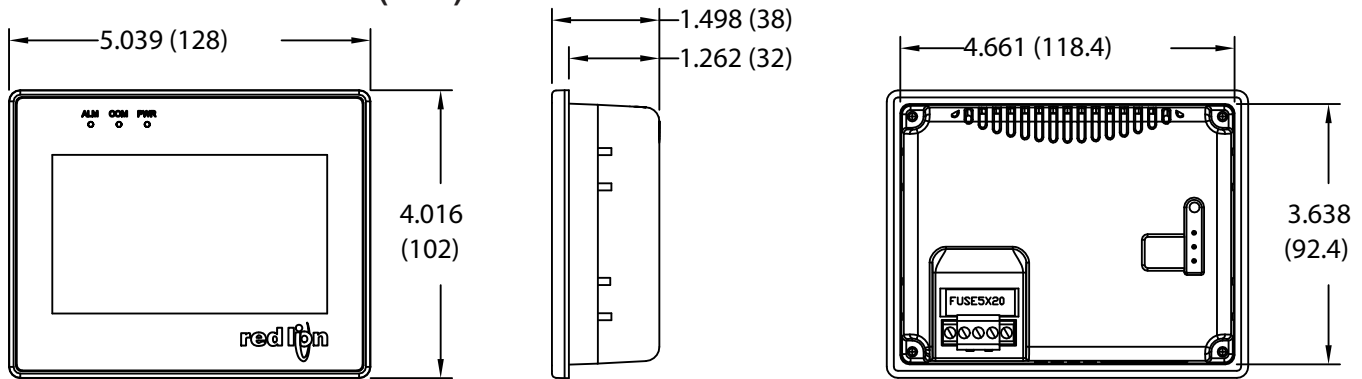

INSTALLING AND POWERING THE G304K

POWER SUPPLY REQUIREMENTS

The G304K requires a 12-28 VDC power supply. Please take care to observe the following points:

- The wire used to connect the operator interface's power supply should be at least 22-gage wire. If a longer cable run is used, a heavier gage wire should be used. The routing of the cable should be kept away from large contactors, inverters, and other devices which may generate significant electrical noise.
- A power supply with a Class 2 or SELV rating is to be used. A Class 2 or SELV power supply provides isolation to accessible circuits from hazardous voltage levels generated by a mains power supply due to single faults. SELV is an acronym for "safety extra-low voltage." Safety extra-low voltage circuits shall exhibit voltages safe to touch both under normal operating conditions and after a single fault, such as a breakdown of a layer of basic insulation or after the failure of a single component has occurred.

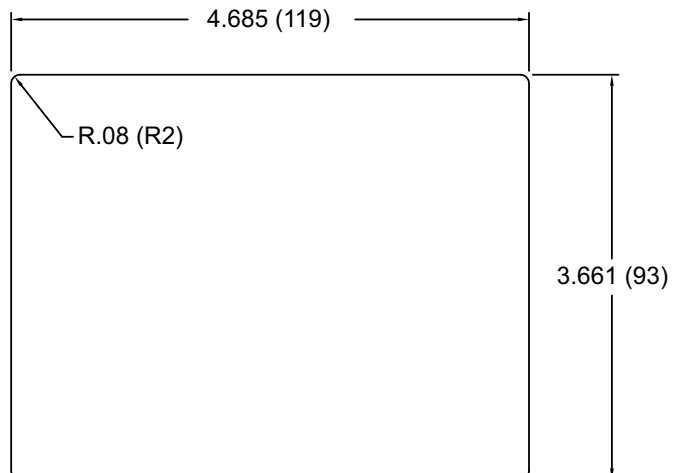

MOUNTING INSTRUCTIONS

The unit can be mounted into enclosures with a depth of 4". It is recommended that the unit be mounted on the front panel of a steel enclosure. Allow clearance of 1" around the sides of the unit for the mounting hardware.

Place the unit in the panel cutout. Slide clamps into the four holes provided at the top and bottom of the case. Tighten the clamping screws in an even pattern until the unit is secured in the panel. Caution: Do not over tighten the clamps. To seal to NEMA4 specifications, all supplied mounting clamps must be used. The panel must not flex more than 0.010".

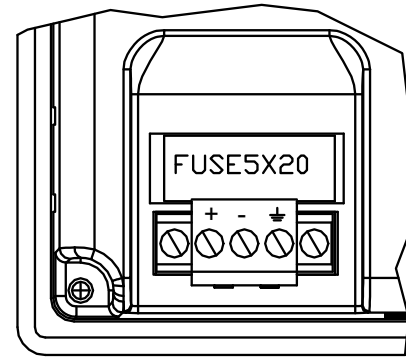

COMMUNICATING WITH THE G304K

The G304K has two serial ports combined into a single DB9-M connector.

PC (RS-232)

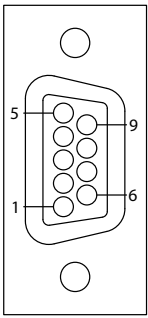

DB9-M

PIN	SYMBOL	PLC (RS-485) 4 wire	PLC (RS-485) 2 wire	PLC (RS-232)	PC (RS-232)
1	Rx-	Rx-	Data-		
2	Rx+	Rx+	Data+		
3	Tx-	Tx-			
4	Tx+	Tx+			
5	GND	Signal Ground			
6	TxD			Transmit	
7	TxD				Transmit
8	RxD				Receive
9	RxD			Receive	

PC CONNECTION

Configuration files are downloaded to the Kadet via the PC port, which can be connected to a computer via various cables.

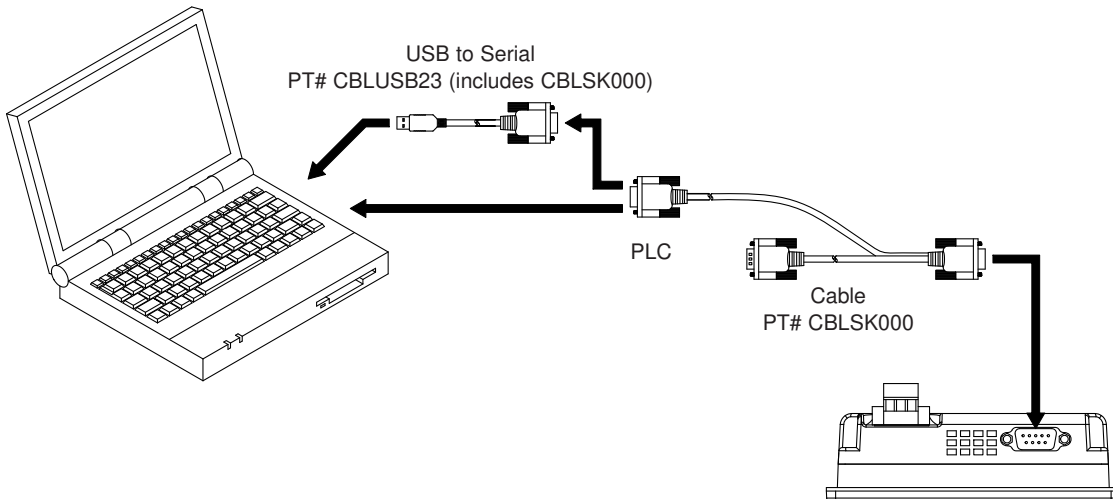

DEVICE COMMUNICATIONS

Several adapters are available which allow direct connection via Red Lion communications cables. For a list of adapters and cables, please visit <http://www.redlion.net/support/downloads.html>.

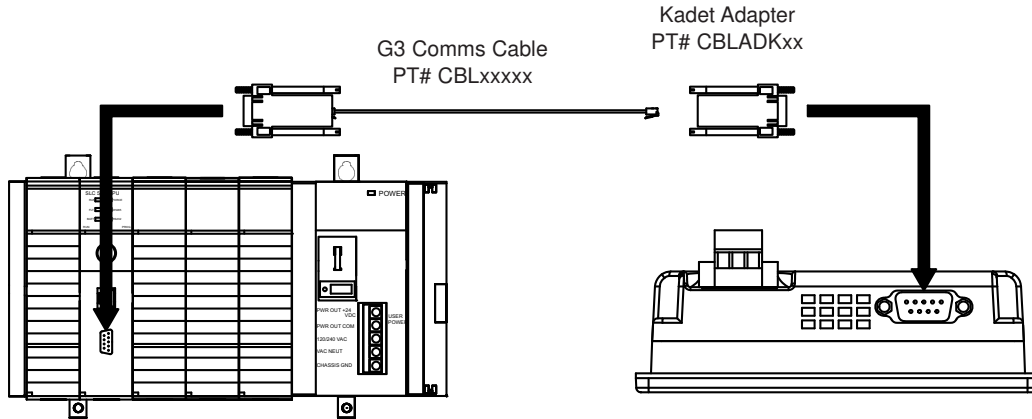

SETTING THE SWITCHES

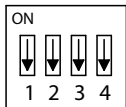

Normal mode.

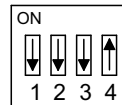

Lowers the intensity of the backlight.

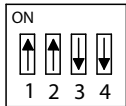

Cycle power or press reset button with the switches as shown in order to display the Clear Database prompt. Touch the left side of the display to clear the database; touch the right side to continue in normal mode.

SOFTWARE/ UNIT OPERATION

CRIMSON SOFTWARE

Crimson software is available as a free download from Red Lion's website or it can be purchased on a CD, see "Ordering Information" for part number. The latest version of the software is always available from the website, and updating your copy is free.

FRONT PANEL LEDS

There are three front panel LEDs. Shown below is the default status of the LEDs.

LED	INDICATION
RED (ALM)	
FLASHING	Tag is in an alarm condition and not acknowledged
STEADY	Acknowledged alarm exists.
FLASHING RAPIDLY	In conjunction with green com LED while unit is in bootloader
GREEN (COM)	
OFF	Communications not established
STEADY	No communication errors are present
FLASHING RAPIDLY	In conjunction with the red ALM LED while the unit is in bootloader.
FLICKERING	Communication error exists
ORANGE (PWR)	
STEADY	Power is applied.

TOUCHSCREEN

This operator interface utilizes a resistive analog touchscreen for user input. The unit will only produce an audible tone (beep) when a touch on an active touchscreen cell is sensed. The touchscreen is fully functional as soon as the operator interface is initialized, and can be operated with gloved hands.

TROUBLESHOOTING YOUR G304K

If for any reason you have trouble operating, connecting, or simply have questions concerning your new G304K, contact Red Lion's technical support. For contact information, refer to the front page of this bulletin for phone and fax numbers.

EMAIL: techsupport@redlion.net

Web Site: <http://www.redlion.net>



CAUTION: The circuit board contains static sensitive components. Before handling the operator interface without the rear cover attached, discharge static charges from your body by touching a grounded bare metal object. Ideally, handle the operator interface at a static controlled clean workstation. Also, do not touch the surface areas of the circuit board. Dirt, oil, or other contaminants may adversely affect circuit operation.