



Chipsmall Limited consists of a professional team with an average of over 10 year of expertise in the distribution of electronic components. Based in Hongkong, we have already established firm and mutual-benefit business relationships with customers from,Europe,America and south Asia,supplying obsolete and hard-to-find components to meet their specific needs.

With the principle of “Quality Parts,Customers Priority,Honest Operation,and Considerate Service”,our business mainly focus on the distribution of electronic components. Line cards we deal with include Microchip,ALPS,ROHM,Xilinx,Pulse,ON,Everlight and Freescale. Main products comprise IC,Modules,Potentiometer,IC Socket,Relay,Connector.Our parts cover such applications as commercial,industrial, and automotives areas.

We are looking forward to setting up business relationship with you and hope to provide you with the best service and solution. Let us make a better world for our industry!



## Contact us

Tel: +86-755-8981 8866 Fax: +86-755-8427 6832

Email & Skype: info@chipsmall.com Web: www.chipsmall.com

Address: A1208, Overseas Decoration Building, #122 Zhenhua RD., Futian, Shenzhen, China



## MODEL G306 - GRAPHIC COLOR LCD OPERATOR INTERFACE TERMINAL WITH QVGA DISPLAY AND TOUCHSCREEN

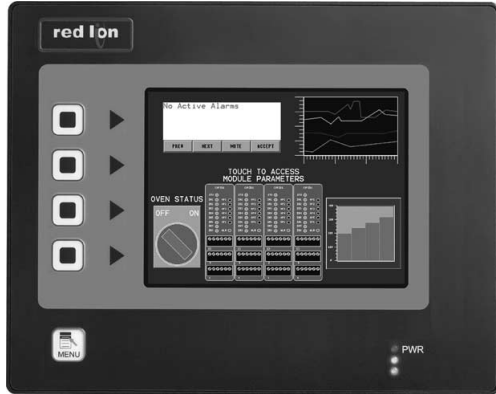

FOR USE IN HAZARDOUS LOCATIONS:  
 Class I, Division 2, Groups A, B, C, and D  
 Class II, Division 2, Groups F and G  
 Class III, Division 2

- CONFIGURED USING CRIMSON SOFTWARE (VERSION 2.0 OR LATER)
- UP TO 5 RS-232/422/485 COMMUNICATIONS PORTS (2 RS-232 AND 1 RS-422/485 ON BOARD, 1 RS-232 AND 1 RS422/485 ON OPTIONAL COMMUNICATIONS CARD)
- 10 BASE T/100 BASE-TX ETHERNET PORT TO NETWORK UNITS AND HOST WEB PAGES
- USB PORT TO DOWNLOAD THE UNIT'S CONFIGURATION FROM A PC OR FOR DATA TRANSFERS TO A PC
- UNIT'S CONFIGURATION IS STORED IN NON-VOLATILE MEMORY (4 MBYTE FLASH)
- COMPACTFLASH® SOCKET TO INCREASE MEMORY CAPACITY
- 5.7-INCH STN PASSIVE MATRIX 256 COLOR QVGA 320 X 240 PIXEL LCD
- 5-BUTTON KEYPAD FOR ON-SCREEN MENUS
- THREE FRONT PANEL LED INDICATORS
- POWER UNIT FROM 24 VDC ±20% SUPPLY
- RESISTIVE ANALOG TOUCHSCREEN

### GENERAL DESCRIPTION

The G306 Operator Interface Terminal combines unique capabilities normally expected from high-end units with a very affordable price. It is built around a high performance core with integrated functionality. This core allows the G306 to perform many of the normal features of the Paradigm range of Operator Interfaces while improving and adding new features.

The G306 is able to communicate with many different types of hardware using high-speed RS232/422/485 communications ports and Ethernet 10 Base T/100 Base-TX communications. In addition, the G306 features USB for fast downloads of configuration files and access to trending and data logging. A CompactFlash socket is provided so that Flash cards can be used to collect your trending and data logging information as well as to store larger configuration files.

In addition to accessing and controlling of external resources, the G306 allows a user to easily view and enter information. Users can enter data through the touchscreen and/or front panel 5-button keypad.

### SAFETY SUMMARY

All safety related regulations, local codes and instructions that appear in the manual or on equipment must be observed to ensure personal safety and to prevent damage to either the instrument or equipment connected to it. If equipment is used in a manner not specified by the manufacturer, the protection provided by the equipment may be impaired.

Do not use the controller to directly command motors, valves, or other actuators not equipped with safeguards. To do so can be potentially harmful to persons or equipment in the event of a fault to the controller.



The protective conductor terminal is bonded to conductive parts of the equipment for safety purposes and must be connected to an external protective earthing system.



WARNING - EXPLOSION HAZARD - SUBSTITUTION OF COMPONENTS MAY IMPAIR SUITABILITY FOR CLASS I, DIVISION 2/CLASS II, DIVISION 2/CLASS III, DIVISION 2



**CAUTION: Risk Of Danger.**  
 Read complete instructions prior to installation and operation of the unit.



**CAUTION: Risk of electric shock.**

### CONTENTS OF PACKAGE

- G306 Operator Interface.
- Panel gasket.
- Template for panel cutout.
- Hardware packet for mounting unit into panel.
- Terminal block for connecting power.

### ORDERING INFORMATION

MODEL NO.	DESCRIPTION	PART NUMBER
G306	Operator Interface for indoor applications, textured finish with embossed keys	G306C000
G3CF	64 MB CompactFlash Card <sup>5</sup>	G3CF064M
	256 MB CompactFlash Card <sup>5</sup>	G3CF256M
	512 MB CompactFlash Card <sup>5</sup>	G3CF512M
G3RS	RS232/485 Optional Communication Card	G3RS0000
G3CN	CANopen Optional Communication Card	G3CN0000
G3PBDP	Profibus DP Optional Communication Card	G3PBDP00
PSDR7	DIN Rail Power Supply	PSDR7000
SFCRM2	Crimson 2.0 <sup>2</sup>	SFCRM200
CBL	RS-232 Programming Cable	CBLPROG0
	USB Cable	CBLUSB00
	Communications Cables <sup>1</sup>	CBLxxxx
DR	DIN Rail Mountable Adapter Products <sup>3</sup>	DRxxxxxx
	Replacement Battery <sup>4</sup>	BNL20000
G3FILM	Protective Films	G3FILM06

<sup>1</sup> Contact your Red Lion distributor or visit our website for complete selection.

<sup>2</sup> Use this part number to purchase Crimson on CD with a printed manual, USB cable, and RS-232 cable. Otherwise, download for free from www.redlion.net.

<sup>3</sup> Red Lion offers RJ modular jack adapters. Refer to the DR literature for complete details.

<sup>4</sup> Battery type is lithium coin type CR2025.

<sup>5</sup> Industrial grade two million write cycles.



# SPECIFICATIONS

## 1. POWER REQUIREMENTS:

Must use Class 2 or SELV rated power supply.  
Power connection via removable three position terminal block.

Supply Voltage: +24 VDC  $\pm 20\%$   
Typical Power<sup>1</sup>: 8 W  
Maximum Power<sup>2</sup>: 14 W

### Notes:

1. Typical power with +24 VDC, RS232/485 communications, Ethernet communications, CompactFlash card installed, and display at full brightness.
2. Maximum power indicates the most power that can be drawn from the G306. Refer to "Power Supply Requirements" under "Installing and Powering the G306."
3. The G306's circuit common is not connected to the enclosure of the unit. See "Connecting to Earth Ground" in the section "Installing and Powering the G306."
4. Read "Power Supply Requirements" in the section "Installing and Powering the G306" for additional power supply information.

## 2. BATTERY: Lithium coin cell. Typical lifetime of 10 years.

## 3. LCD DISPLAY:

SIZE	5.7-inch
TYPE	STN
COLORS	256
PIXELS	320 X 240
BRIGHTNESS	165 cd/m <sup>2</sup>
BACKLIGHT*	20,000 HR TYP.

\*Lifetime at room temperature. Refer to "Display" in "Software/Unit Operation"

## 4. 5-KEY KEYPAD: for on-screen menus.

## 5. TOUCHSCREEN: Resistive analog

## 6. MEMORY:

**On Board User Memory:** 4 Mbyte of non-volatile Flash memory.  
**Memory Card:** CompactFlash Type II slot for Type I and Type II CompactFlash cards.

## 7. COMMUNICATIONS:

**USB Port:** Adheres to USB specification 1.1. Device only using Type B connection.



WARNING - DO NOT CONNECT OR DISCONNECT CABLES WHILE POWER IS APPLIED UNLESS AREA IS KNOWN TO BE NON-HAZARDOUS. USB PORT IS FOR SYSTEM SET-UP AND DIAGNOSTICS AND IS NOT INTENDED FOR PERMANENT CONNECTION.

**Serial Ports:** Format and Baud Rates for each port are individually software programmable up to 115,200 baud.

PGM Port: RS232 port via RJ12.

COMMS Ports: RS422/485 port via RJ45, and RS232 port via RJ12.

DH485 TXEN: Transmit enable; open collector,  $V_{OH} = 15$  VDC,  
 $V_{OL} = 0.5$  V @ 25 mA max.

*Note: For additional information on the communications or signal common and connections to earth ground please see the "Connecting to Earth Ground" in the section "Installing and Powering the G306."*

**Ethernet Port:** 10 BASE-T / 100 BASE-TX

RJ45 jack is wired as a NIC (Network Interface Card).

Isolation from Ethernet network to G3 operator interface: 1500 Vrms

## 8. ENVIRONMENTAL CONDITIONS:

**Operating Temperature Range:** 0 to 50°C

**Storage Temperature Range:** -20 to 70°C

**Operating and Storage Humidity:** 80% maximum relative humidity (non-condensing) from 0 to 50°C.

**Vibration:** Operational 5 to 8 Hz, 0.8" (p-p), 8 to 500 Hz, in X, Y, Z direction, duration: 1 hour, 3 g.

**Shock:** Operational 40 g, 9 msec in 3 directions.

**Altitude:** Up to 2000 meters.

## 9. CERTIFICATIONS AND COMPLIANCES:

### SAFETY

UL Recognized Component, File #E179259, UL61010-1, CSA 22.2 No.61010-1 Recognized to U.S. and Canadian requirements under the Component Recognition Program of Underwriters Laboratories, Inc.

UL Listed, File #E211967, UL61010-1, UL1604, CSA 22.2 No. 61010.1, CSA 22.2 No. 213-M1987

LISTED by Und. Lab. Inc. to U.S. and Canadian safety standards

Type 4X Enclosure rating (Face only), UL50

IECEE CB Scheme Test Certificate #US/9737A/UL,

CB Scheme Test Report #E179259-V01-S04

Issued by Underwriters Laboratories Inc.

IEC 61010-1, EN 61010-1: Safety requirements for electrical equipment for measurement, control, and laboratory use, Part 1.

IP66 Enclosure rating (Face only), IEC 529

### ELECTROMAGNETIC COMPATIBILITY

Emissions and Immunity to EN 61326: Electrical Equipment for Measurement, Control and Laboratory use.

### Immunity to Industrial Locations:

Electrostatic discharge	EN 61000-4-2	Criterion A 4 kV contact discharge 8 kV air discharge
Electromagnetic RF fields	EN 61000-4-3	Criterion A 10 V/m
Fast transients (burst)	EN 61000-4-4	Criterion A 2 kV power 1 kV signal
Surge	EN 61000-4-5	Criterion A 1 kV L-L, 2 kV L&N-E power
RF conducted interference	EN 61000-4-6	Criterion A 3 V/rms

### Emissions:

Emissions EN 55011 Class A

### Note:

1. Criterion A: Normal operation within specified limits.

## 10. CONNECTIONS: Compression cage-clamp terminal block.

Wire Gage: 12-30 AWG copper wire

Torque: 5-7 inch-pounds (56-79 N-cm)

## 11. CONSTRUCTION: Steel rear metal enclosure with NEMA 4X/IP66 aluminum front plate for indoor use only when correctly fitted with the gasket provided. Installation Category II, Pollution Degree 2.

## 12. MOUNTING REQUIREMENTS: Maximum panel thickness is 0.25" (6.3 mm). For NEMA 4X/IP66 sealing, a steel panel with a minimum thickness of 0.125" (3.17 mm) is recommended.

**Maximum Mounting Stud Torque:** 17 inch-pounds (1.92 N-m)

## 13. WEIGHT: 3.0 lbs (1.36 Kg)

## DIMENSIONS In inches (mm)

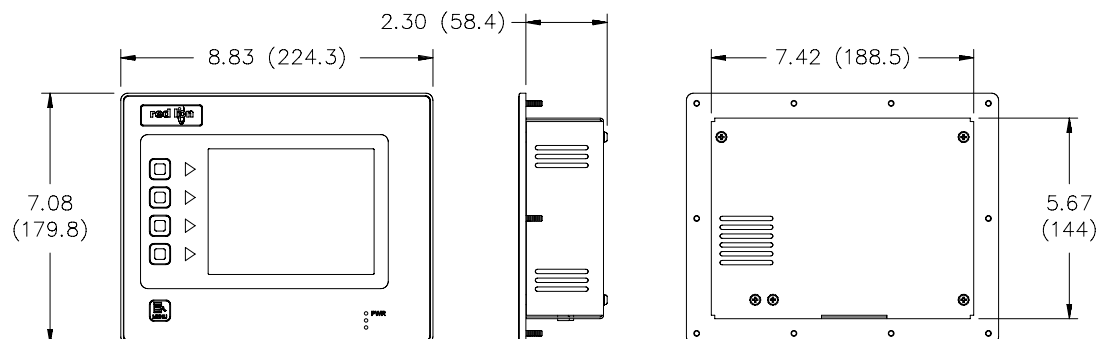



# INSTALLING AND POWERING THE G306

## MOUNTING INSTRUCTIONS

This operator interface is designed for through-panel mounting. A panel cut-out diagram and a template are provided. Care should be taken to remove any loose material from the mounting cut-out to prevent that material from falling into the operator interface during installation. A gasket is provided to enable sealing to NEMA 4X/IP66 specification. Install the ten keps nuts provided and tighten evenly for uniform gasket compression.

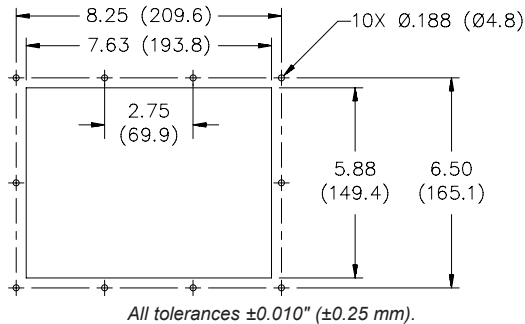
*Note: Tightening the keps nuts beyond a maximum of 17 inch-pounds (1.92 N-m) may cause damage to the front panel.*





ALL NONINCENDIVE CIRCUITS MUST BE WIRED USING DIVISION 2 WIRING METHODS AS SPECIFIED IN ARTICLE 501-4 (b), 502-4 (b), AND 503-3 (b) OF THE NATIONAL ELECTRICAL CODE, NFPA 70 FOR INSTALLATION WITHIN THE UNITED STATES, OR AS SPECIFIED IN SECTION 19-152 OF CANADIAN ELECTRICAL CODE FOR INSTALLATION IN CANADA.

## CONNECTING TO EARTH GROUND



The protective conductor terminal is bonded to conductive parts of the equipment for safety purposes and must be connected to an external protective earthing system.

Each G306 has a chassis ground terminal on the back of the unit. Your unit should be connected to earth ground (protective earth).

# COMMUNICATING WITH THE G306

## CONFIGURING A G306

The G306 is configured using Crimson software. Crimson is available as a free download from Red Lion's website, or it can be purchased on CD. Updates to Crimson for new features and drivers are posted on the website as they become available. By configuring the G306 using the latest version of Crimson, you are assured that your unit has the most up to date feature set. Crimson software can configure the G306 through the RS232 PGM port, USB port, or CompactFlash.

The USB port is connected using a standard USB cable with a Type B connector. The driver needed to use the USB port will be installed with Crimson.

The RS232 PGM port uses a programming cable made by Red Lion to connect to the DB9 COM port of your computer. If you choose to make your own cable, use the "G306 Port Pin Out Diagram" for wiring information.

The CompactFlash can be used to program a G3 by placing a configuration file and firmware on the CompactFlash card. The card is then inserted into the target G3 and powered. Refer to the Crimson literature for more information on the proper names and locations of the files.

## USB, DATA TRANSFERS FROM THE COMPACTFLASH CARD



WARNING - DO NOT CONNECT OR DISCONNECT CABLES WHILE POWER IS APPLIED UNLESS AREA IS KNOWN TO BE NON-HAZARDOUS. USB PORT IS FOR SYSTEM SET-UP AND DIAGNOSTICS AND IS NOT INTENDED FOR PERMANENT CONNECTION.

In order to transfer data from the CompactFlash card via the USB port, a driver must be installed on your computer. This driver is installed with Crimson and is located in the folder C:\Program Files\Red Lion Controls\Crimson 2.0\Device\ after Crimson is installed. This may have already been accomplished if your G306 was configured using the USB port.

Once the driver is installed, connect the G306 to your PC with a USB cable, and follow "Mounting the CompactFlash" instructions in the Crimson 2 user manual.

The chassis ground is not connected to signal common of the unit. Maintaining isolation between earth ground and signal common is not required to operate your unit. But, other equipment connected to this unit may require isolation between signal common and earth ground. *To maintain isolation between signal common and earth ground care must be taken when connections are made to the unit.* For example, a power supply with isolation between its signal common and earth ground must be used. Also, plugging in a USB cable may connect signal common and earth ground.<sup>1</sup>

1. USB's shield may be connected to earth ground at the host. USB's shield in turn may also be connected to signal common.

## POWER SUPPLY REQUIREMENTS

The G306 requires a 24 VDC power supply. Your unit may draw considerably less than the maximum rated power depending upon the options being used. As additional features are used your unit will draw increasing amounts of power. Items that could cause increases in current are additional communications, optional communications card, CompactFlash card, and other features programmed through Crimson.

In any case, it is very important that the power supply is mounted correctly if the unit is to operate reliably. Please take care to observe the following points:

- The power supply must be mounted close to the unit, with usually not more than 6 feet (1.8 m) of cable between the supply and the operator interface. Ideally, the shortest length possible should be used.
- The wire used to connect the operator interface's power supply should be at least 22-gage wire. If a longer cable run is used, a heavier gage wire should be used. The routing of the cable should be kept away from large contactors, inverters, and other devices which may generate significant electrical noise.
- A power supply with a Class 2 or SELV rating is to be used. A Class 2 or SELV power supply provides isolation to accessible circuits from hazardous voltage levels generated by a mains power supply due to single faults. SELV is an acronym for "safety extra-low voltage." Safety extra-low voltage circuits shall exhibit voltages safe to touch both under normal operating conditions and after a single fault, such as a breakdown of a layer of basic insulation or after the failure of a single component has occurred.

## CABLES AND DRIVERS

Red Lion has a wide range of cables and drivers for use with many different communication types. A list of these drivers and cables along with pin out is available from Red Lion's website. New cables and drivers are added on a regular basis. If making your own cable, refer to the "G306 Port Pin Outs" for wiring information.

## ETHERNET COMMUNICATIONS

Ethernet communications can be established at either 10 BASE-T or 100 BASE-TX. The G306 unit's RJ45 jack is wired as a NIC (Network Interface Card). For example, when wiring to a hub or switch use a straight-through cable, but when connecting to another NIC use a crossover cable.

The Ethernet connector contains two LEDs. A yellow LED in the upper right, and a bi-color green/amber LED in the upper left. The LEDs represent the following statuses:

LED COLOR	DESCRIPTION
YELLOW solid	Link established.
YELLOW flashing	Data being transferred.
GREEN	10 BASE-T Communications
AMBER	100 BASE-TX Communications

On the rear of each unit is a unique 12-digit MAC address and a block for marking the unit with an IP address. Refer to the Crimson manual and Red Lion's website for additional information on Ethernet communications.

# RS232 PORTS

The G306 has two RS232 ports. There is the PGM port and the COMMS port. Although only one of these ports can be used for programming, both ports can be used for communications with a PLC.

The RS232 ports can be used for either master or slave protocols with any G306 configuration.

Examples of RS232 communications could involve another Red Lion product or a PC. By using a cable with RJ12 ends on it, and a twist in the cable, RS232 communications with another G3 product or the Modular Controller can be established. Red Lion part numbers for cables with a twist in them are CBLPROG0<sup>1</sup>, CBLRLC01<sup>2</sup>, or CBLRC02<sup>3</sup>.

## G3 RS232 to a PC

Connections			
G3: RJ12	Name	PC: DB9	Name
4	COMM	1	DCD
5	Tx	2	Rx
2	Rx	3	Tx
	N/C	4	DTR
3	COM	5	GND
	N/C	6	DSR
1	CTS	7	RTS
6	RTS	8	CTS
	N/C	9	RI

## CONNECTING A G306 OPERATOR INTERFACE TO AN ICM5

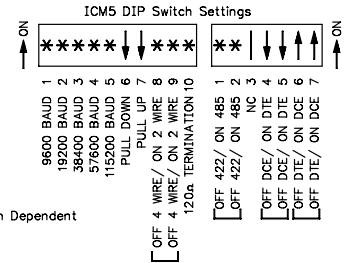
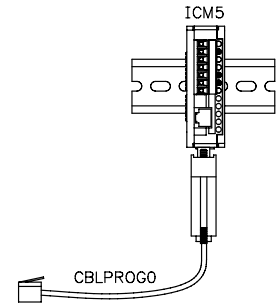
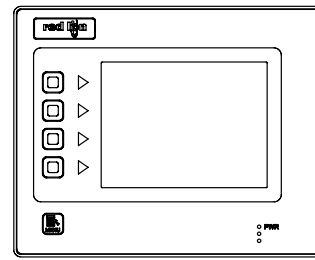

- <sup>1</sup> CBLPROG0 can also be used to communicate with either a PC or an ICM5.
- <sup>2</sup> DB9 adapter not included, 1 foot long.
- <sup>3</sup> DB9 adapter not included, 10 feet long.

## G306 PORT PIN OUTS

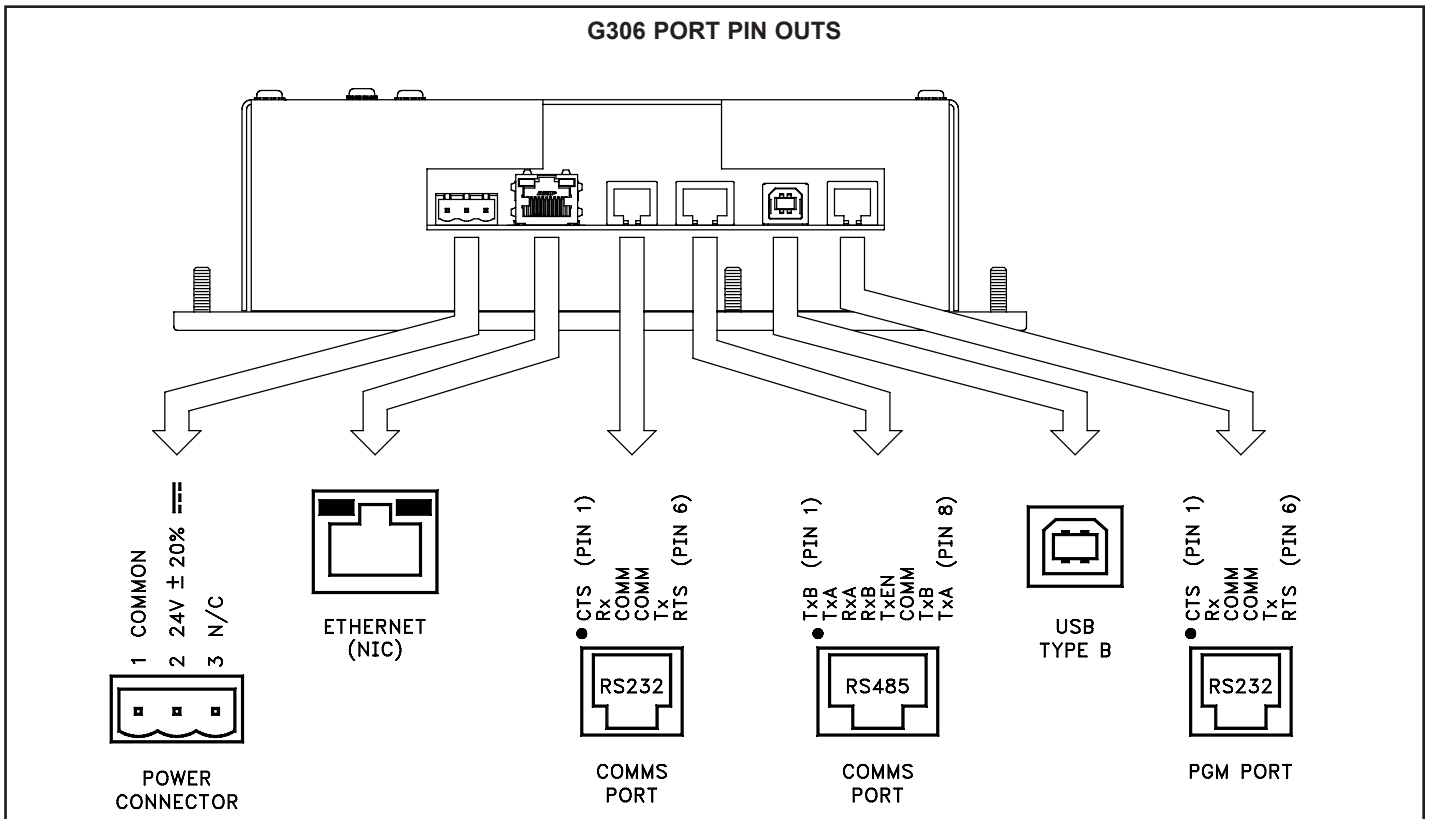

## RS422/485 COMMS PORT

The G306 has one RS422/485 port. This port can be configured to act as either RS422 or RS485.

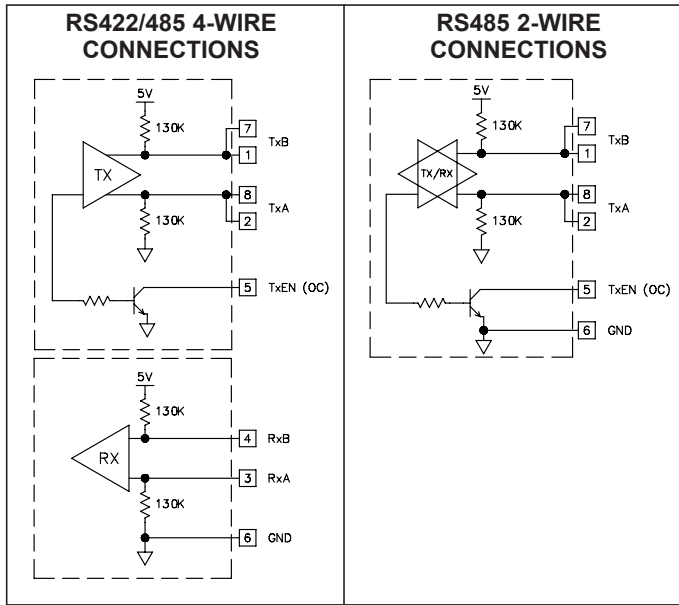

*Note: All Red Lion devices connect A to A and B to B, except for Paradigm devices. Refer to [www.redlion.net](http://www.redlion.net) for additional information.*

## DH485 COMMUNICATIONS

The G306's RS422/485 COMMS port can also be used for Allen Bradley DH485 communications.

**WARNING: DO NOT** use a standard DH485 cable to connect this port to Allen Bradley equipment. A cable and wiring diagram are available from Red Lion.

### G3 to AB SLC 500 (CBLAB003)

Connections			
RJ45: RLC	Name	RJ45: A-B	Name
1	TxB	1	A
2	TxA	2	B
3, 8	RxA	-	24V
4, 7	RxB	-	COMM
5	TxEN	5	TxEN
6	COMM	4	SHIELD
4, 7	TxB	-	COMM
3, 8	TxA	-	24V

## Examples of RS485 2-Wire Connections

### G3 to Red Lion RJ11 (CBLRLC00) DLC, IAMS, ITMS, PAXCDC4C

Connections			
G3: RJ45	Name	RLC: RJ11	Name
5	TxEN	2	TxEN
6	COM	3	COM
1	TxB	5	B-
2	TxA	4	A+

### G3 to Modular Controller (CBLRLC05)

Connections			
G3	Name	Modular Controller	Name
1,4	TxB	1,4	TxB
4,1	RxB	4,1	RxB
2,3	TxA	2,3	TxA
3,2	RxA	3,2	RxA
5	TxEN	5	TxEN
6	COM	6	COM
7	TxB	7	TxB
8	TxA	8	TxA

# SOFTWARE/UNIT OPERATION

## CRIMSON SOFTWARE

Crimson software is available as a free download from Red Lion's website or it can be purchased on a CD, see "Ordering Information" for part number. The latest version of the software is always available from the website, and updating your copy is free.

## DISPLAY

This operator interface uses a liquid crystal display (LCD) for displaying text and graphics. The display utilizes a cold cathode fluorescent tube (CCFL) for lighting the display. The CCFL tubes can be dimmed for low light conditions.

These CCFL tubes have a limited lifetime. Backlight lifetime is based upon the amount of time the display is turned on at full intensity. Turning the backlight off when the display is not in use can extend the lifetime of your backlight. This can be accomplished through the Crimson software when configuring your unit.

## FRONT PANEL LEDs

There are three front panel LEDs. Shown below is the default status of the LEDs.

LED	INDICATION
RED (TOP, LABELED "PWR")	
FLASHING	Unit is in the boot loader, no valid configuration is loaded. <sup>1</sup>
STEADY	Unit is powered and running an application.
YELLOW (MIDDLE)	
OFF	No CompactFlash card is present.
STEADY	Valid CompactFlash card present.
FLASHING RAPIDLY	CompactFlash card being checked.
FLICKERING	Unit is writing to the CompactFlash, either because it is storing data, or because the PC connected via the USB port has locked the drive. <sup>2</sup>
FLASHING SLOWLY	Incorrectly formatted CompactFlash card present.
GREEN (BOTTOM)	
FLASHING	A tag is in an alarm state.
STEADY	Valid configuration is loaded and there are no alarms present.

1. The operator interface is shipped without a configuration. After downloading a configuration, if the light remains in the flashing state continuously, try cycling power. If the LED still continues to flash, try downloading a configuration again.
2. Do not turn off power to the unit while this light is flickering. The unit writes data in two minute intervals. Later Microsoft operating systems will not lock the drive unless they need to write data; Windows 98 may lock the drive any time it is mounted, thereby interfering with logging. Refer to "Mounting the CompactFlash" in the Crimson 2 User Manual.

## TOUCHSCREEN

This operator interface utilizes a resistive analog touchscreen for user input. The unit will only produce an audible tone (beep) when a touch on an active touchscreen cell is sensed. The touchscreen is fully functional as soon as the operator interface is initialized, and can be operated with gloved hands.

## KEYPAD

The G306 keypad consists of five keys that can be used for on-screen menus.

## TROUBLESHOOTING YOUR G306

If for any reason you have trouble operating, connecting, or simply have questions concerning your new G306, contact Red Lion's technical support. For contact information, refer to the back page of this bulletin for phone and fax numbers.

EMAIL: [techsupport@redlion.net](mailto:techsupport@redlion.net)

Web Site: <http://www.redlion.net>

## BATTERY & TIME KEEPING



WARNING - EXPLOSION HAZARD - THE AREA MUST BE KNOWN TO BE NON-HAZARDOUS BEFORE SERVICING/ REPLACING THE UNIT AND BEFORE INSTALLING OR REMOVING I/O WIRING AND BATTERY.



WARNING - EXPLOSION HAZARD - DO NOT DISCONNECT EQUIPMENT UNLESS POWER HAS BEEN DISCONNECTED AND THE AREA IS KNOWN TO BE NON-HAZARDOUS.

A battery is used to keep time when the unit is without power. Typical accuracy of the G306 time keeping is less than one minute per month drift. The battery of a G306 unit does not affect the unit's memory, all configurations and data is stored in non-volatile memory.



### CAUTION: RISK OF ELECTRIC SHOCK

The inverter board, attached to the mounting plate, supplies the high voltage to operate the backlight. Touching the inverter board may result in injury to personnel.



**CAUTION:** The circuit board contains static sensitive components. Before handling the operator interface without the rear cover attached, discharge static charges from your body by touching a grounded bare metal object. Ideally, handle the operator interface at a static controlled clean workstation. Also, do not touch the surface areas of the circuit board. Dirt, oil, or other contaminants may adversely affect circuit operation.

To change the battery of a G306, remove power, cabling, and then the rear cover of the unit. To remove the cover, remove the four screws designated by the arrows on the rear of the unit. Then, by lifting the top side, hinge the cover, thus providing clearance for the connectors on the bottom side of the PCB as shown in the illustration below. Install in the reverse manner.

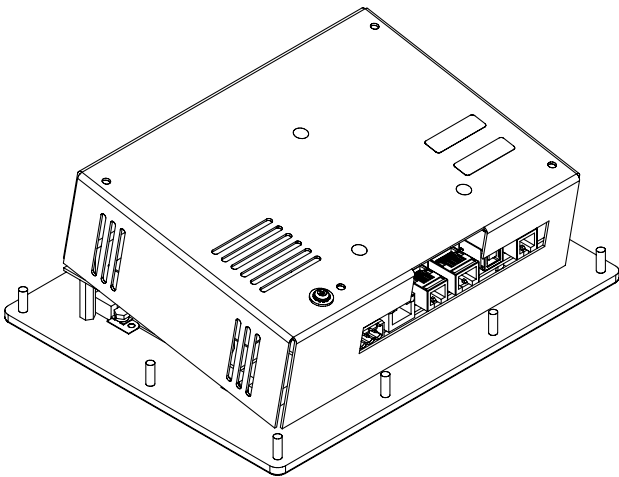

Remove the old battery\* from the holder and replace with the new battery. Replace the rear cover, cables, and re-apply power. Using Crimson or the unit's keypad, enter the correct time and date.

*\* Please note that the old battery must be disposed of in a manner that complies with your local waste regulations. Also, the battery must not be disposed of in fire, or in a manner whereby it may be damaged and its contents come into contact with human skin.*

*The battery used by the G306 is a lithium type CR2025.*

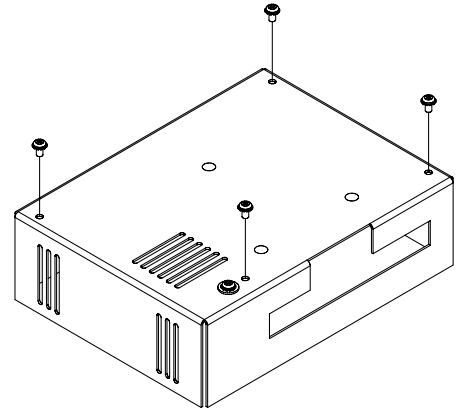

BATTERY

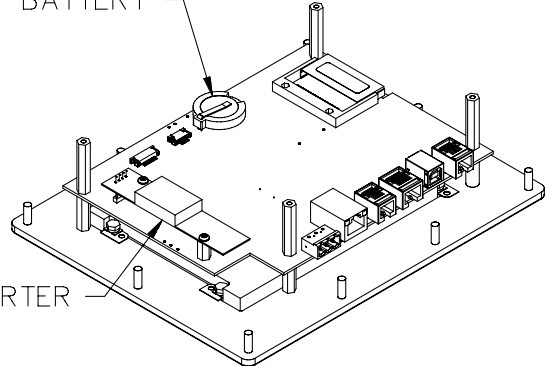

INVERTER



# OPTIONAL FEATURES AND ACCESSORIES

## OPTIONAL COMMUNICATION CARD

Red Lion offers optional communication cards for fieldbus communications. These communication cards will allow your G306 to communicate with many of the popular fieldbus protocols.

Red Lion is also offering a communications card for additional RS232 and RS422/485 communications. Visit Red Lion's website for information and availability of these cards.

## CUSTOM LOGO

Each G3 operator interface has an embossed area containing the Red Lion logo. Red Lion can provide custom logos to apply to this area. Contact your distributor for additional information and pricing.

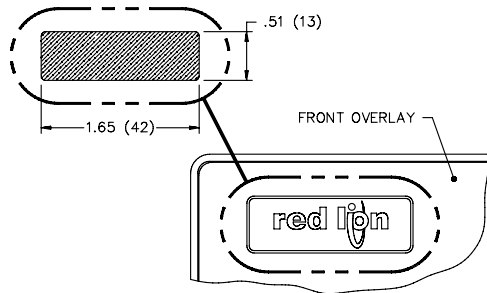

## COMPACTFLASH SOCKET

CompactFlash socket is a Type II socket that can accept either Type I or II cards. Use cards with a minimum of 4 Mbytes and a maximum of 2 Gbytes with the G306's CompactFlash socket. Cards are available at most computer and office supply retailers.

CompactFlash can be used for configuration transfers, larger configurations, data logging, and trending.

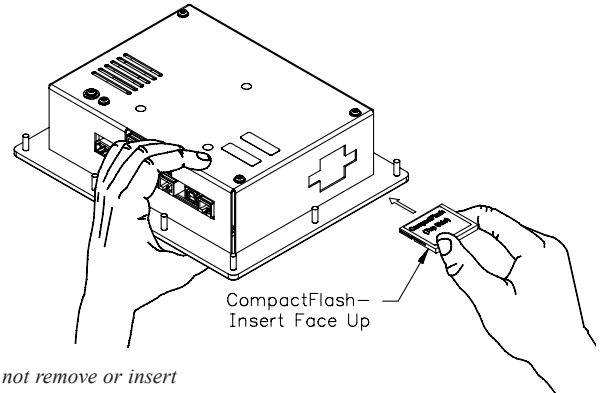

*Note: Do not remove or insert the CompactFlash card while power is applied. Refer to "Front Panel LEDs."*

Information stored on a CompactFlash card by a G306 can be read by a card reader attached to a PC. This information is stored in IBM (Windows®) PC compatible FAT16 file format.

## NOTE

For reliable operation in all of our products, Red Lion recommends the use of SanDisk® and SimpleTech brands of CompactFlash cards.

Industrial grade versions that provide up to two million write/erase cycles minimum are available from Red Lion.

## LIMITED WARRANTY

The Company warrants the products it manufactures against defects in materials and workmanship for a period limited to two years from the date of shipment, provided the products have been stored, handled, installed, and used under proper conditions. The Company's liability under this limited warranty shall extend only to the repair or replacement of a defective product, at The Company's option. The Company disclaims all liability for any affirmation, promise or representation with respect to the products.

The customer agrees to hold Red Lion Controls harmless from, defend, and indemnify RLC against damages, claims, and expenses arising out of subsequent sales of RLC products or products containing components manufactured by RLC and based upon personal injuries, deaths, property damage, lost profits, and other matters which Buyer, its employees, or sub-contractors are or may be to any extent liable, including without limitation penalties imposed by the Consumer Product Safety Act (P.L. 92-573) and liability imposed upon any person pursuant to the Magnuson-Moss Warranty Act (P.L. 93-637), as now in effect or as amended hereafter.

No warranties expressed or implied are created with respect to The Company's products except those expressly contained herein. The Customer acknowledges the disclaimers and limitations contained herein and relies on no other warranties or affirmations.

Red Lion Controls  
20 Willow Springs Circle  
York PA 17406  
Tel +1 (717) 767-6511  
Fax +1 (717) 764-0839

Red Lion Controls BV  
Printerweg 10  
NL - 3821 AD Amersfoort  
Tel +31 (0) 334 723 225  
Fax +31 (0) 334 893 793

Red Lion Controls AP  
31, Kaki Bukit Road 3,  
#06-04/05 TechLink  
Singapore 417818  
Tel +65 6744-6613  
Fax +65 6743-3360