



Chipsmall Limited consists of a professional team with an average of over 10 year of expertise in the distribution of electronic components. Based in Hongkong, we have already established firm and mutual-benefit business relationships with customers from,Europe,America and south Asia,supplying obsolete and hard-to-find components to meet their specific needs.

With the principle of “Quality Parts,Customers Priority,Honest Operation,and Considerate Service”,our business mainly focus on the distribution of electronic components. Line cards we deal with include Microchip,ALPS,ROHM,Xilinx,Pulse,ON,Everlight and Freescale. Main products comprise IC,Modules,Potentiometer,IC Socket,Relay,Connector.Our parts cover such applications as commercial,industrial, and automotives areas.

We are looking forward to setting up business relationship with you and hope to provide you with the best service and solution. Let us make a better world for our industry!



Contact us

Tel: +86-755-8981 8866 Fax: +86-755-8427 6832

Email & Skype: info@chipsmall.com Web: www.chipsmall.com

Address: A1208, Overseas Decoration Building, #122 Zhenhua RD., Futian, Shenzhen, China



G3S/G3SD

Solid State Relays

Ultra-small Relay Breaks up to 1 A

- Ultra-small, dual in-line package (DIP) SSR.
- Terminals are compatible with G6B Electromagnetic Relay's. Be capable mix with G6Bs as the application requires.
- Close mounting possible. In addition, heat sink dedicated to this mounting style also available.
- Both AC- and DC-load versions available.
- High isolation of 2,500 VAC between input and output.
- Built-in varistor effectively absorbs external surges (for AC switching).
- Lineup includes models with UL and CSA certification (model numbers ending in "-US").

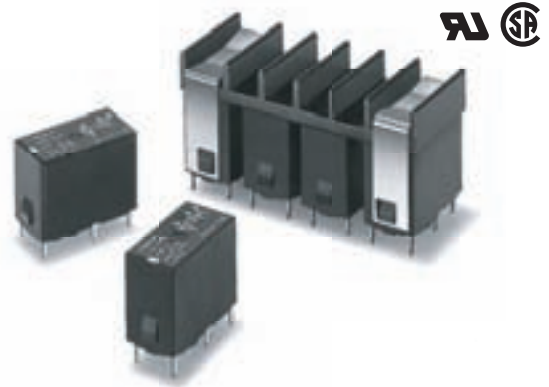

RoHS Compliant



Refer to "Solid State Relays Common Precautions".

List of Models

Isolation	Zero cross function	Indicator	Rated output load	Rated input voltage	Model	Minimum packing unit
Phototriac	No	No	1 A 100 to 240 VAC *1	5 VDC	G3S-201PL	100 pcs
				12 VDC		
				24 VDC		
			1.2 A 100 to 240 VAC *1	5 VDC	G3S-201PL-PD	
				12 VDC		
				24 VDC		
Photocoupler	No	No	1 A 4 to 24 VDC *2	5 VDC	G3SD-Z01P	
				12 VDC		
				24 VDC		
			1.1 A 4 to 24 VDC *2	5 VDC	G3SD-Z01P-PD	
				12 VDC		
				24 VDC		

*1. Product is labelled "250 VAC". *2 Product is labelled "24 VDC".

Ratings

Input (Each models has 5-VDC, 12-VDC, and 24-VDC input versions.)

Rated voltage	Operating voltage	Must operate voltage level	Must release voltage level	Impedance	
				G3S-201PL G3S-201PL-PD	G3SD-Z01P G3SD-Z01P-PD
5 VDC	4 to 6 VDC	4 VDC max.	1 VDC min.	450 Ω ±20%	630 Ω ±20%
12 VDC	9.6 to 14.4 VDC	9.6 VDC max.		1.1 kΩ ±20%	1.5 kΩ ±20%
24 VDC	19.2 to 28.8 VDC	19.2 VDC max.		2.2 kΩ ±20%	2.8 kΩ ±20%

Output

Model	Item	Rated load voltage	Rated load voltage range	Load current	Inrush current
G3S-201PL		100 to 240 VAC	75 to 264 VAC	0.1 to 1 A *	15 A (60 Hz, 1 cycle)
G3S-201PL-PD				0.1 to 1.2 A *	
G3SD-Z01P		4 to 24 VDC	3 to 26 VDC	0.01 to 1 A *	3 A (10 ms)
G3SD-Z01P-PD				0.01 to 1.1 A *	

* The applicable output load current varies depending on the ambient temperature. Refer to reference data the "Load Current vs. Ambient Temperature" rating characteristic for details.

Characteristics

Item	Model	G3S-201PL, G3S-201PL-PD	G3SD-Z01P, G3SD-Z01P-PD
Operate time		1 ms max.	1 ms max.
Release time		1/2 of load power source cycle + 1 ms max.	1 ms max.
Output ON voltage drop		1.6 V (RMS) max.	1.5 V max.
Leakage current		2 mA (at 200 VAC)	0.1 mA max. (at 26 VDC)
Insulation resistance		100 MΩ min. (at 500 VDC)	
Dielectric strength		2,500 VAC, 50/60 Hz for 1 min between input and output	
Vibration resistance		10 to 55 to 10 Hz, 0.75-mm single amplitude (1.5-mm double amplitude)	
Shock resistance		1,000 m/s ²	
Storage temperature		-30°C to 100°C (with no icing or condensation)	
Ambient operating temperature		-30°C to 80°C (with no icing or condensation)	
Ambient operating humidity		45% to 85% RH	
Weight		Approx. 13 g	

Engineering Data

Load Current vs Ambient Temperature Characteristics

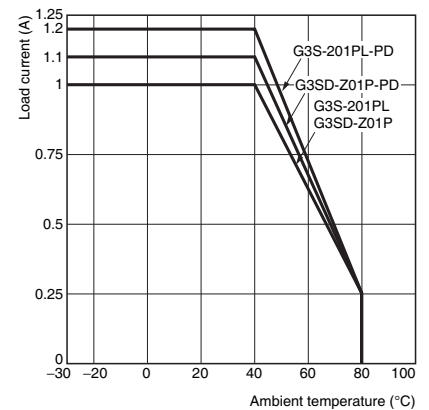

One Cycle Surge Current: Non-repetitive

Non-repetitive (Keep the inrush current to half the rated value if it occurs repetitively.)

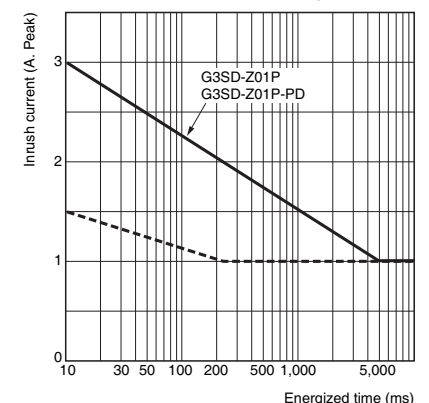
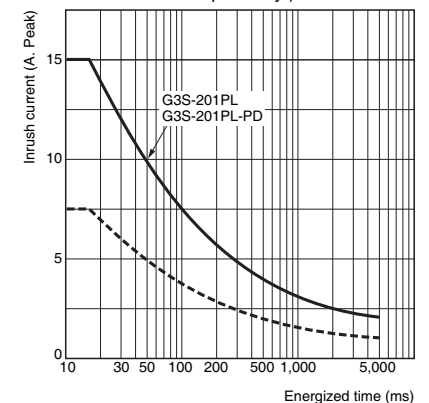

■Dimensions

(Unit: mm)

G3S
G3SD

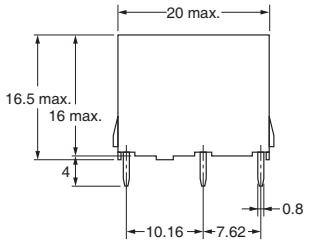
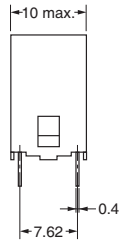
Mounting Holes
(BOTTOM VIEW)
Tolerance: ± 0.1 mm

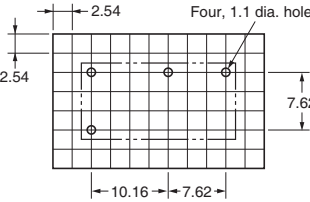

Terminal Arrangement/
Internal Connections
(BOTTOM VIEW)

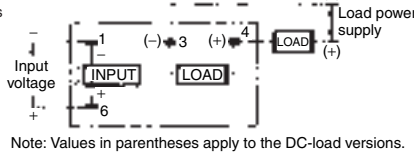

Note: Values in parentheses apply to the DC-load versions.

■Connecting Socket

G6B-04P

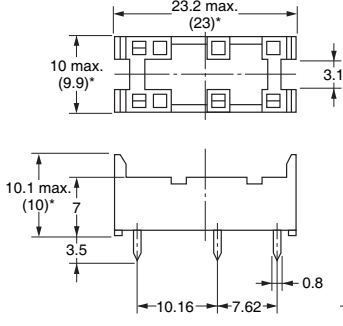
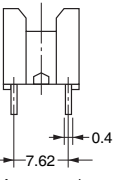
* Average value

Mounting Holes
(BOTTOM VIEW)
Tolerance: ± 0.1 mm

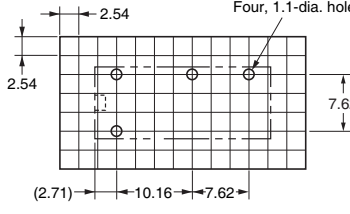

Model	P6B-04P
Minimum order quantity (pcs)	20

Note: Order the models below in increments of the minimum quantity packaged.

Heat Sink
Y92B-S08N

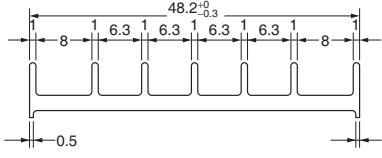
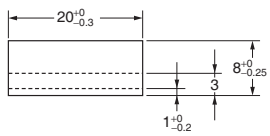
Mounting Bracket

Model	Y92B-S08N
-------	-----------

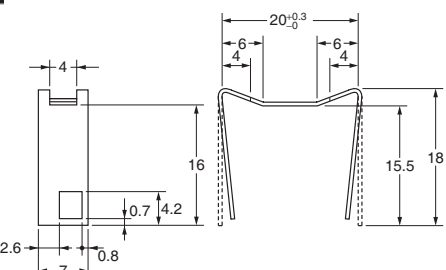
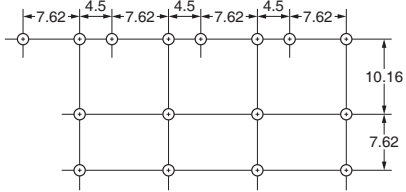
Note: The Y92B-S08N Relay is composed of heat sink with two mounting tools.

■Safety Precautions

- Please refer to "Solid State Relays Common Precautions" for correct use.

Precautions for Correct Use

• Close Mounting

G3S-201PL-PD and G3SD-Z01-PD SSRs can be closely mounted side by side. Attach the Y92B-S08N Heat Sink to the SSRs mounted closely side by side. When these SSRs are mounted side by side, the load current vs. ambient

temperature characteristic declines as shown below. Apply a thin layer of Momentive Performance Materials's YG6260 or Shin-Etsu Chemical's G747, or similar product to the heat sink before mounting. When these SSRs are mounted side by side (with heat sink), the load current vs. ambient temperature characteristic declines as shown on the right.

• Load Current vs. Ambient Temperature Characteristics

(When four SSRs are mounted closely side by side and each of them is switched to the same load current)

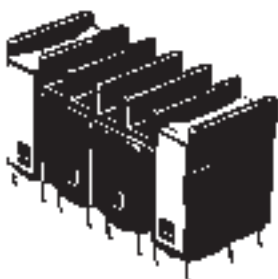
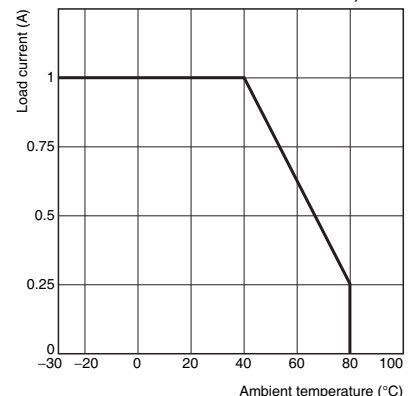

- Application examples provided in this document are for reference only. In actual applications, confirm equipment functions and safety before using the product.
- Consult your OMRON representative before using the product under conditions which are not described in the manual or applying the product to nuclear control systems, railroad systems, aviation systems, vehicles, combustion systems, medical equipment, amusement machines, safety equipment, and other systems or equipment that may have a serious influence on lives and property if used improperly. Make sure that the ratings and performance characteristics of the product provide a margin of safety for the system or equipment, and be sure to provide the system or equipment with double safety mechanisms.

Note: Do not use this document to operate the Unit.