



Chipsmall Limited consists of a professional team with an average of over 10 year of expertise in the distribution of electronic components. Based in Hongkong, we have already established firm and mutual-benefit business relationships with customers from,Europe,America and south Asia,supplying obsolete and hard-to-find components to meet their specific needs.

With the principle of “Quality Parts,Customers Priority,Honest Operation,and Considerate Service”,our business mainly focus on the distribution of electronic components. Line cards we deal with include Microchip,ALPS,ROHM,Xilinx,Pulse,ON,Everlight and Freescale. Main products comprise IC,Modules,Potentiometer,IC Socket,Relay,Connector.Our parts cover such applications as commercial,industrial, and automotives areas.

We are looking forward to setting up business relationship with you and hope to provide you with the best service and solution. Let us make a better world for our industry!



Contact us

Tel: +86-755-8981 8866 Fax: +86-755-8427 6832

Email & Skype: info@chipsmall.com Web: www.chipsmall.com

Address: A1208, Overseas Decoration Building, #122 Zhenhua RD., Futian, Shenzhen, China



MOS FET Relays

G3VM-351AY/DY

Compact, General-purpose, Analog-switching MOS FET Relays, with Dielectric Strength of 5 kVAC between I/O Using Optical Isolation.

- Trigger LED forward current of 2 mA (maximum) facilitates power saving designs.
- Switches minute analog signals.
- Continuous load current of 100 mA.



NEW

Note: The actual product is marked differently from the image shown here.

RoHS compliant

⚠ Refer to "Common Precautions".

Application Examples

- Power meter
- Measurement devices
- Security systems
- Industrial equipment

List of Models

Contact form	Terminals	Load voltage (peak value) (See the note.)	Model	Number per stick	Number per tape
SPST-NO	PCB terminals	350 V	G3VM-351AY	100	---
	Surface-mounting terminals		G3VM-351DY		
			G3VM-351DY(TR)	---	1,500

Note: The AC peak and DC value are given for the load voltage.

Dimensions

Note: All units are in millimeters unless otherwise indicated.

G3VM-351AY

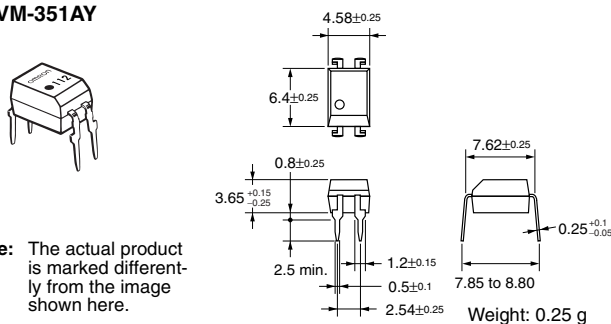

Note: The actual product is marked differently from the image shown here.

G3VM-351DY

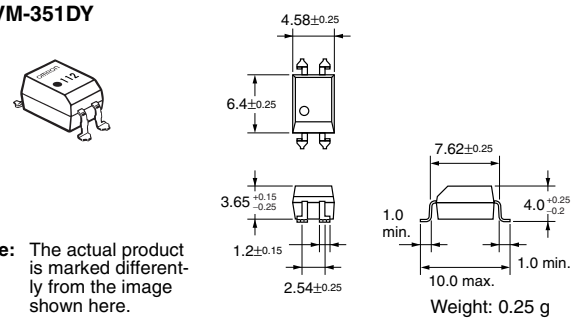

Note: The actual product is marked differently from the image shown here.

Terminal Arrangement/Internal Connections (Top View)

G3VM-351AY

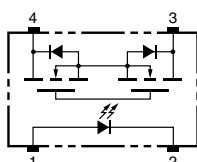

G3VM-351DY

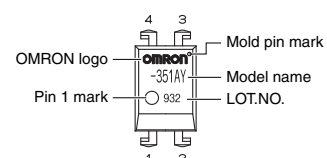
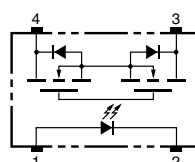

Note: The actual product is marked differently from the image shown here.

PCB Dimensions (Bottom View)

G3VM-351AY

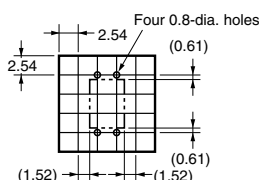

Actual Mounting Pad Dimensions (Recommended Value, Top View)

G3VM-351DY

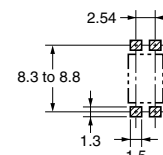

Absolute Maximum Ratings (Ta = 25°C)

Item	Symbol	Rating	Unit	Measurement Conditions	
Input	LED forward current	I_F	30	mA	
	Repetitive peak LED forward current	I_{FP}	1	A	100 μ s pulses, 100 pps
	LED forward current reduction rate	$\Delta I_F/^\circ\text{C}$	-0.3	mA/ $^\circ\text{C}$	Ta \geq 25°C
	LED reverse voltage	V_R	5	V	
	Connection temperature	T_j	125	$^\circ\text{C}$	
Output	Load voltage (AC peak/DC)	V_{OFF}	350	V	
	Continuous load current (AC peak/DC)	I_O	100	mA	
	ON current reduction rate	$\Delta I_O/^\circ\text{C}$	-1.0	mA/ $^\circ\text{C}$	Ta \geq 25°C
	Pulse ON current	I_{op}	0.3	A	t = 100 ms, Duty = 1/10
	Connection temperature	T_j	125	$^\circ\text{C}$	
Dielectric strength between input and output (See note 1.)	V_{I-O}	5,000	Vrms	AC for 1 min	
Operating temperature	T_a	-40 to +85	$^\circ\text{C}$	With no icing or condensation	
Storage temperature	T_{stg}	-55 to +125	$^\circ\text{C}$	With no icing or condensation	
Soldering temperature (10 s)	---	260	$^\circ\text{C}$	10 s	

Note: 1. The dielectric strength between the input and output was checked by applying voltage between all pins as a group on the LED side and all pins as a group on the light-receiving side.

Electrical Characteristics (Ta = 25°C)

Item	Symbol	Minimum	Typical	Maximum	Unit	Measurement conditions	
Input	LED forward voltage	V_F	1.45	1.63	1.75	V	$I_F = 10$ mA
	Reverse current	I_R	---	---	10	μA	$V_R = 5$ V
	Capacity between terminals	C_T	---	40	---	pF	V = 0, f = 1 MHz
	Trigger LED forward current	I_{FT}	---	0.3	2	mA	$I_O = 100$ mA
Output	Maximum resistance with output ON	R_{ON}	---	25	35	Ω	$I_F = 5$ mA, $I_O = 100$ mA, t < 1 s
			---	35	50		$I_F = 5$ mA, $I_O = 100$ mA
	Current leakage when the relay is open	I_{LEAK}	---	---	1.0	μA	$V_{OFF} = 350$ V
Capacity between terminals	C_{OFF}	---	30	---	pF	V = 0, f = 1 MHz	
Capacity between I/O terminals	C_{I-O}	---	0.8	---	pF	f = 1 MHz, Vs = 0 V	
Insulation resistance	R_{I-O}	1,000	---	---	M Ω	$V_{I-O} = 500$ VDC, RoH \leq 60%	
Turn-ON time	tON	---	0.1	1	ms	$I_F = 5$ mA, $R_L = 200$ Ω , $V_{DD} = 20$ V (See note 2.)	
Turn-OFF time	tOFF	---	0.2	1	ms		

Note: 2. Turn-ON and Turn-OFF Times

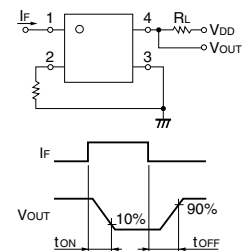

Recommended Operating Conditions

Use the G3VM under the following conditions so that the Relay will operate properly.

Item	Symbol	Minimum	Typical	Maximum	Unit
Load voltage (AC peak/DC)	V_{DD}	---	---	280	V
Operating LED forward current	I_F	3	5	20	mA
Continuous load current (AC peak/DC)	I_O	---	---	100	mA
Operating temperature	T_a	-20	---	65	$^\circ\text{C}$

Engineering Data

Load Current vs. Ambient Temperature

G3VM-351AY(DY)

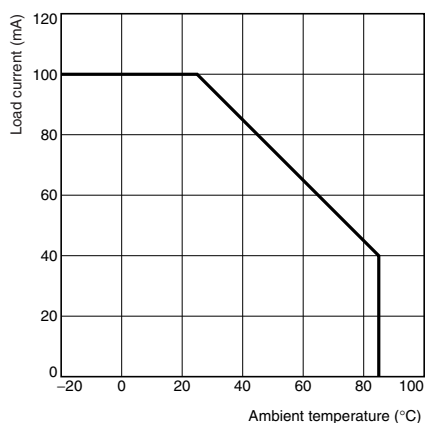

Safety Precautions

Refer to "Common Precautions" for all G3VM models.