



Chipsmall Limited consists of a professional team with an average of over 10 year of expertise in the distribution of electronic components. Based in Hongkong, we have already established firm and mutual-benefit business relationships with customers from,Europe,America and south Asia,supplying obsolete and hard-to-find components to meet their specific needs.

With the principle of “Quality Parts,Customers Priority,Honest Operation,and Considerate Service”,our business mainly focus on the distribution of electronic components. Line cards we deal with include Microchip,ALPS,ROHM,Xilinx,Pulse,ON,Everlight and Freescale. Main products comprise IC,Modules,Potentiometer,IC Socket,Relay,Connector.Our parts cover such applications as commercial,industrial, and automotives areas.

We are looking forward to setting up business relationship with you and hope to provide you with the best service and solution. Let us make a better world for our industry!



Contact us

Tel: +86-755-8981 8866 Fax: +86-755-8427 6832

Email & Skype: info@chipsmall.com Web: www.chipsmall.com

Address: A1208, Overseas Decoration Building, #122 Zhenhua RD., Futian, Shenzhen, China



G4E180 Series Centrifugal Blower

Ø 180mm

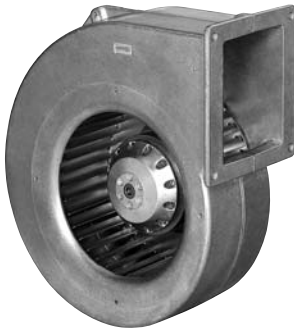

- AC single inlet, forward curved centrifugal blower. Via a bracket, the integrated external-rotor motor is mounted on one side of the housing.
- Direction of rotation is CW as seen from suction side. Insulation class "B".
- Maintenance-free ball bearings.
- UL, CSA, VDE approvals on some models, please contact application engineering.
- Housing of die-cast aluminium and impeller of galvanised sheet-steel. Forward curved impellers are directly press-fitted onto the rotor of the external-rotor motor.

Part Number	Curve	CFM @ 0	VAC	Hertz	Power (W)	dBA	Max Amb. Temp. C	Bearing Type	Features	Capacitor (µF)	Wgt. (lbs)
G4E180-AB09-15	1	350	115	60	146	65	45	Ball	Leads	10	8.15
G4E180-AB01-01	1	350	230	60*	145	65	45	Ball	Leads	3	8.15

*50 Hz data available.

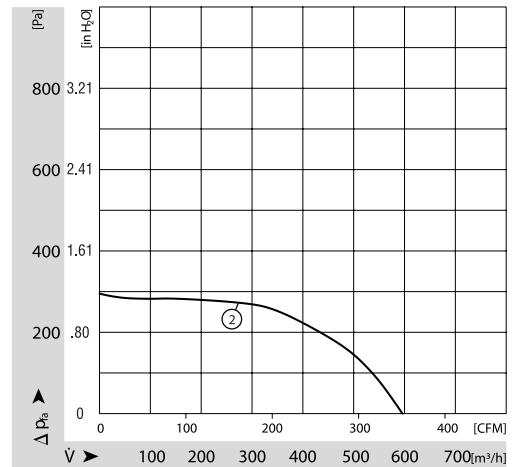
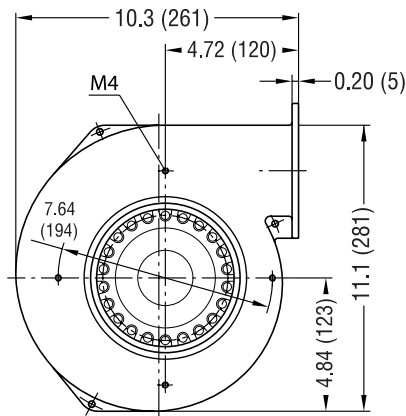
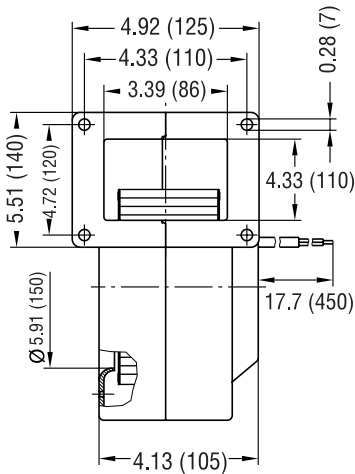

ebmpapst

e-mail: sales@us.ebmpapst.com · TEL: 860-674-1515 · FAX: 860-674-8536
 ebm-papst Inc., 100 Hyde Road, Farmington, CT 06034 USA

ebm-papst Inc., 2006 © ebm-papst Inc. reserves the right to change any specifications or data without notice