



Chipsmall Limited consists of a professional team with an average of over 10 year of expertise in the distribution of electronic components. Based in Hongkong, we have already established firm and mutual-benefit business relationships with customers from,Europe,America and south Asia,supplying obsolete and hard-to-find components to meet their specific needs.

With the principle of “Quality Parts,Customers Priority,Honest Operation,and Considerate Service”,our business mainly focus on the distribution of electronic components. Line cards we deal with include Microchip,ALPS,ROHM,Xilinx,Pulse,ON,Everlight and Freescale. Main products comprise IC,Modules,Potentiometer,IC Socket,Relay,Connector.Our parts cover such applications as commercial,industrial, and automotives areas.

We are looking forward to setting up business relationship with you and hope to provide you with the best service and solution. Let us make a better world for our industry!



## Contact us

Tel: +86-755-8981 8866 Fax: +86-755-8427 6832

Email & Skype: info@chipsmall.com Web: www.chipsmall.com

Address: A1208, Overseas Decoration Building, #122 Zhenhua RD., Futian, Shenzhen, China



## PSE Technology Corporation

# SPECIFICATION FOR APPROVAL

CUSTOMER	
NOMINAL FREQUENCY	32.768 KHz
PRODUCT TYPE	<b>TYPE G8 SMD CRYSTAL</b>
SPEC. NO. ( P/N )	G83270025
CUSTOMER P/N	
ISSUE DATE	Jun.16,2016
VERSION	A

APPROVED	PREPARED	QA
<i>Brenda</i>	<i>Clair</i>	<i>Song Yang</i>
<b>APPROVED BY CUSTOMER :</b>		<b>AVL Status</b>
<b>Please return one copy with approval to PSE-TW</b>		

### PSE Technology Corporation

No.2, Tzu-Chiang 5th Rd, Chung Li Industrial Park,  
 Chung Li City, Taoyuan County, Taiwan (R.O.C.)  
 TEL: 886-3-451-8888  
 FAX: 886-3-461-3865  
<http://www.saronix-ecera.com.tw>

\*RoHS Compliant



# TYPE G8 SMD CRYSTAL

**G83270025**

VER. A 16-Jun-16

## ELECTRICAL SPECIFICATIONS

**SRe Part Number : G83270025**

Parameters	Symbol	Specifications	Units	Notes
Nominal Frequency	Fn	32.768	KHz	
Frequency Tolerance	FT	± 20	ppm	at 25 °C ± 5 °C
Load Capacitance	CL	9	pF	Typ.
Drive Level	DL	0.1 / 0.5	µW	Typ. / Max.
Equivalent Series Resistance	ESR	70	KΩ	Max.
Temperature Coefficient	K	-0.03	ppm/°C <sup>2</sup>	± 0.01ppm/°C <sup>2</sup>
Operating Temperature Range	TR	-40 to 85	°C	
Shunt Capacitance	C0	1.5	pF	Typ.
Motional Capacitance	C1	6.5	fF	Typ.
Quality Factor	Q	13	K	Min.
Aging		± 3	ppm	Max. 1st year
Storage Temperature Range		-40 to 85	°C	
Insulation Resistance		500	MΩ	Min.

## Reliability ( Mechanical and environmental performances )

No.	Test Items	Conditions	Requirements
1	Bending test	Apply pressure in the direction of the arrow at a rate of about 0.5mm/s until bent width reaches 5mm, and hold for 30 seconds.	<ul style="list-style-type: none"><li>• Without mechanical damage such as breaks and satisfy sealing specification.</li><li>• Frequency change: Within ±5ppm</li><li>• Equivalent series resistance(E.S.R) change: Within 5kΩ</li></ul>
2	Shear test	Apply 20N(2.04kgf) static load to the core of quartz crystal units in the direction of the arrow using a R0.5 scratch tool, then hold for 5 seconds.	
3	Core body strength	Apply 10N(1.02kgf) static load to the quartz crystal units center in the direction of the arrow using a R0.5 pushing tool, then hold for 10 seconds.	
4	Vibration	Frequency sweep method shall be applied as follows. Quartz crystal units shall be vibrated with the sweeping frequency from 10Hz to 55Hz and return to 10Hz in 1 minute, with 1.5mm amplitude. This vibration shall be applied for 2 hours in each 3 perpendicular axes. Other procedures conform to JIS C 60068-2-6.	
5	Shock	Quartz crystal units shall be accelerated at 9810m/s <sup>2</sup> by 1ms pulse duration. This shock shall be applied 3 times in each 3 perpendicular axes. Other procedures conform to JIS C 60068-2-27.	

# TYPE G8 SMD CRYSTAL

**G83270025**

VER. A 16-Jun-16

6	Cold	Quartz crystal units shall be stored in the $-40\pm 3^{\circ}\text{C}$ atmosphere for 1000 hours. Other procedures conform to JIS C 60068-2-1.	<ul style="list-style-type: none"> <li>• Frequency change: Within <math>\pm 5\text{ppm}</math></li> <li>• Equivalent series resistance(E.S.R) change: Within <math>5\text{k}\Omega</math></li> </ul>														
7	Dry heat	Quartz crystal units shall be stored in the $100\pm 2^{\circ}\text{C}$ atmosphere for 100 hours. Other procedures conform to JIS C 60068-2-2.	<ul style="list-style-type: none"> <li>• After conditioning, quartz crystal units shall be subjected to standard atmospheric conditions for 1 hour, and measured.</li> </ul>														
8	Damp heat	Quartz crystal units shall be stored in the $40\pm 2^{\circ}\text{C}$ atmosphere with 90 to 95% relative humidity for 1000 hours. Other procedures conform to JIS C 60068-2-3.															
9	Change of temperature	Quartz crystal units shall be subjected successively 100 cycles of temperature change shown below. Other procedures conform to JIS C 0025.															
		<table border="1"> <thead> <tr> <th></th> <th>Temperature</th> <th>Duration</th> </tr> </thead> <tbody> <tr> <td>1</td> <td><math>-40\pm 3^{\circ}\text{C}</math></td> <td>30min.</td> </tr> <tr> <td>2</td> <td>Normal temperature</td> <td>Within 30 sec.</td> </tr> <tr> <td>3</td> <td><math>100\pm 2^{\circ}\text{C}</math></td> <td>30min.</td> </tr> <tr> <td>4</td> <td>Normal temperature</td> <td>Within 30 sec.</td> </tr> </tbody> </table>			Temperature	Duration	1	$-40\pm 3^{\circ}\text{C}$	30min.	2	Normal temperature	Within 30 sec.	3	$100\pm 2^{\circ}\text{C}$	30min.	4	Normal temperature
	Temperature	Duration															
1	$-40\pm 3^{\circ}\text{C}$	30min.															
2	Normal temperature	Within 30 sec.															
3	$100\pm 2^{\circ}\text{C}$	30min.															
4	Normal temperature	Within 30 sec.															
10	Sealing	Both the test methods specified below shall be applied.															
		Quartz crystal units shall be soaked in $90^{\circ}\text{C}$ or higher temperature hot water for 5 minutes.	<ul style="list-style-type: none"> <li>• Without repetitive leaking bubbles from quartz crystal units.</li> </ul>														
		Quartz crystal units shall be tested by Mass spectrometric leakage detector to measure the leakage rate of helium gas.	<ul style="list-style-type: none"> <li>• <math>1\times 10^{-9}\text{ Pa}\cdot\text{m}^3/\text{s}</math> or less</li> </ul>														
11	Aging	Quartz crystal units shall be stored in the $85\pm 3^{\circ}\text{C}$ atmosphere for $720\pm 12$ hours.	<ul style="list-style-type: none"> <li>• Frequency change: Within <math>\pm 5\text{ppm}</math></li> <li>• Equivalent series resistance(E.S.R) change: Within <math>5\text{k}\Omega</math></li> <li>• After conditioning, quartz crystal units shall be subjected to standard atmospheric conditions for 1 hour, and measured.</li> </ul>														
12	Solder-ability	Terminals coated with flux shall be immersed in the solder bath for $3.5\pm 0.5$ seconds.	<ul style="list-style-type: none"> <li>• Minimum 95% of immersed terminal shall be covered with new uniform solder.</li> </ul>														
		<table border="1"> <thead> <tr> <th></th> <th>Items</th> <th>Conditions</th> </tr> </thead> <tbody> <tr> <td>1</td> <td>Solder</td> <td>Sn-3.0Ag-0.5Cu</td> </tr> <tr> <td>2</td> <td>Flux</td> <td>Approximately 25wt% methanol(JIS K 8891) solution of resin(JIS K 5902).</td> </tr> <tr> <td>3</td> <td>Solder temperature</td> <td><math>245\pm 5^{\circ}\text{C}</math></td> </tr> </tbody> </table>			Items	Conditions	1	Solder	Sn-3.0Ag-0.5Cu	2	Flux	Approximately 25wt% methanol(JIS K 8891) solution of resin(JIS K 5902).	3	Solder temperature	$245\pm 5^{\circ}\text{C}$		
				Items	Conditions												
1	Solder	Sn-3.0Ag-0.5Cu															
2	Flux	Approximately 25wt% methanol(JIS K 8891) solution of resin(JIS K 5902).															
3	Solder temperature	$245\pm 5^{\circ}\text{C}$															

# TYPE G8 SMD CRYSTAL

G83270025

VER. A 16-Jun-16

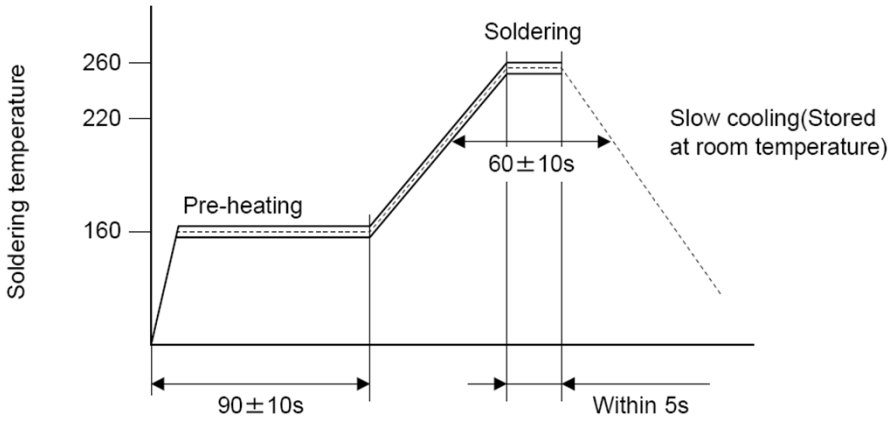
13	Resistance to soldering heat	<p>Reflow soldering method</p> <p style="text-align: center;">Temperature profile</p>  <p>Peak temperature: <math>260\pm 5^{\circ}\text{C}</math> for within 5seconds. Soldering temperature: <math>220^{\circ}\text{C}</math> or higher for <math>60\pm 10</math> seconds. Pre-heating temperature: <math>160\pm 10^{\circ}\text{C}</math> for <math>90\pm 10</math> seconds. Quartz crystal units which is put on PCB shall be through reflow soldering furnace twice with the condition shown above.</p>	<ul style="list-style-type: none"> <li>• Frequency change: Within <math>\pm 5\text{ppm}</math></li> <li>• Equivalent series resistance (E.S.R) change: Within <math>10\text{k}\Omega</math></li> <li>• After conditioning, quartz crystal units shall be subjected to standard atmospheric conditions for 1 hour, and measured.</li> <li>• Without distinct deformation in appearance.</li> </ul>
		<p>Hot Air method</p> <p>Apply hot air for <math>7\pm 0.5</math>seconds, distance 10mm, <math>300\pm 5^{\circ}\text{C}</math>, flow 10L/minutes</p>	<ul style="list-style-type: none"> <li>• Frequency change: Within <math>\pm 5\text{ppm}</math></li> <li>• Equivalent series resistance(E.S.R) change: Within <math>5\text{k}\Omega</math></li> <li>• After conditioning, quartz crystal units shall be subjected to standard atmospheric conditions for 1 hour, and measured.</li> <li>• Without distinct deformation in appearance.</li> </ul>
14	Solubility to resistance	<p>Soak cleaning</p> <p>Quartz crystal units shall be soaked in isopropyl alcohol at normal temperature for 90 seconds.</p>	<ul style="list-style-type: none"> <li>• Without mechanical damage such as breaks and satisfy sealing specification.</li> <li>• Frequency change: Within <math>\pm 5\text{ppm}</math></li> <li>• Equivalent series resistance(E.S.R) change: Within <math>5\text{k}\Omega</math></li> <li>• Without distinct deformation in appearance.</li> <li>• Marking shall be legible.</li> </ul>

# TYPE G8 SMD CRYSTAL

G83270025

VER. A 16-Jun-16

## Marking

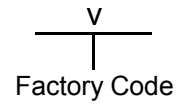
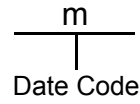
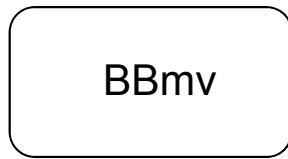

## Dimensions (Units: mm)

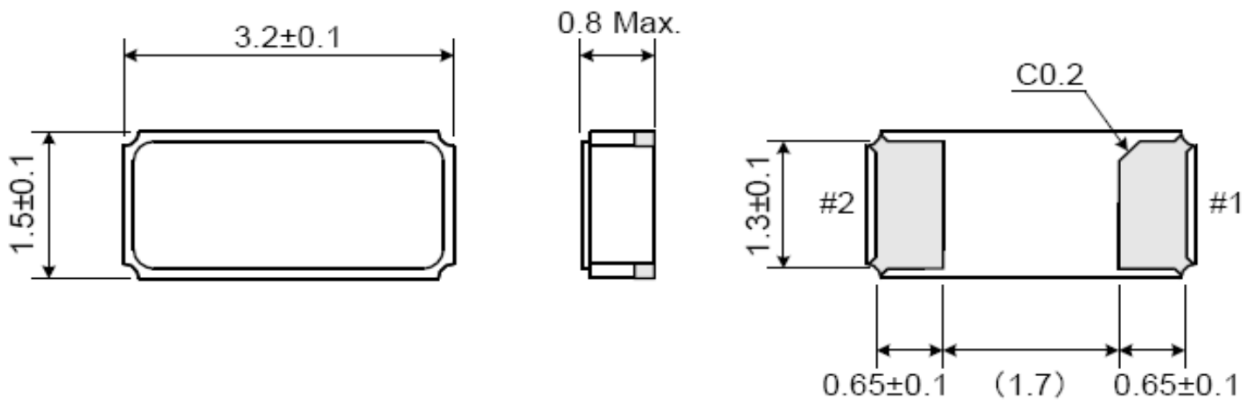

## Recommended Soldering Pattern

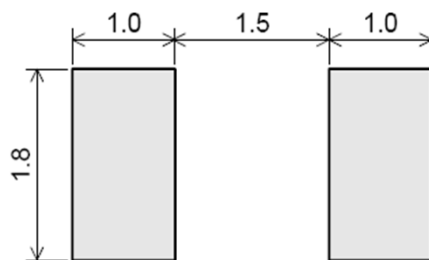

## Internal connection

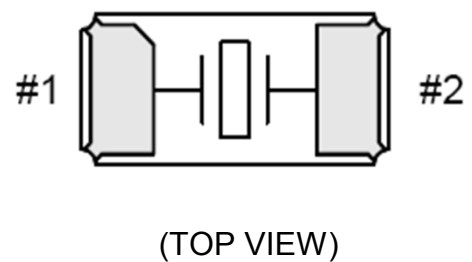

# TYPE G8 SMD CRYSTAL

G83270025

VER. A 16-Jun-16

## TAPING (Units: mm)

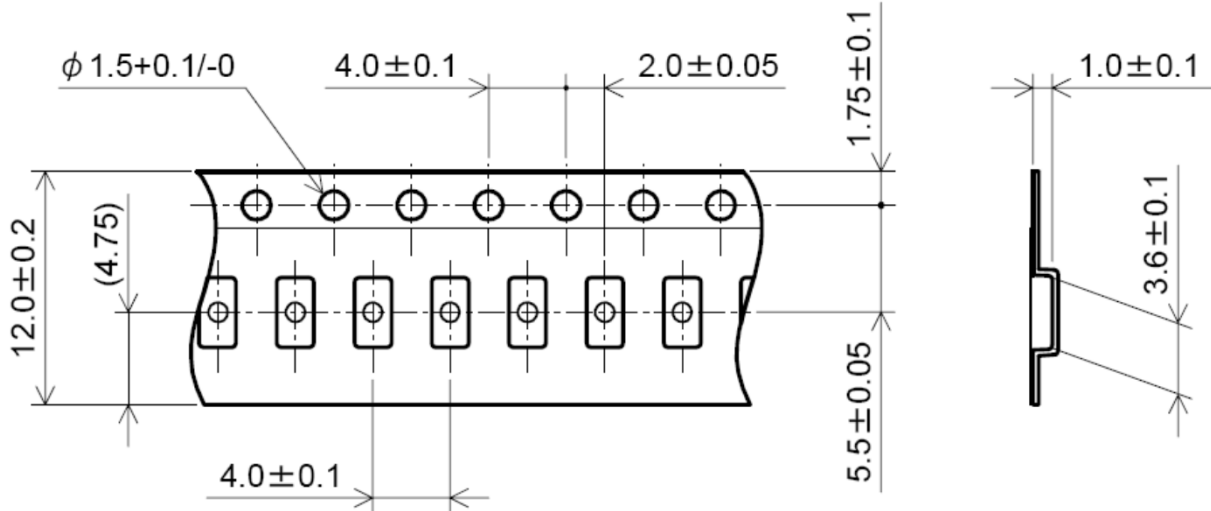

## REEL (Units: mm)

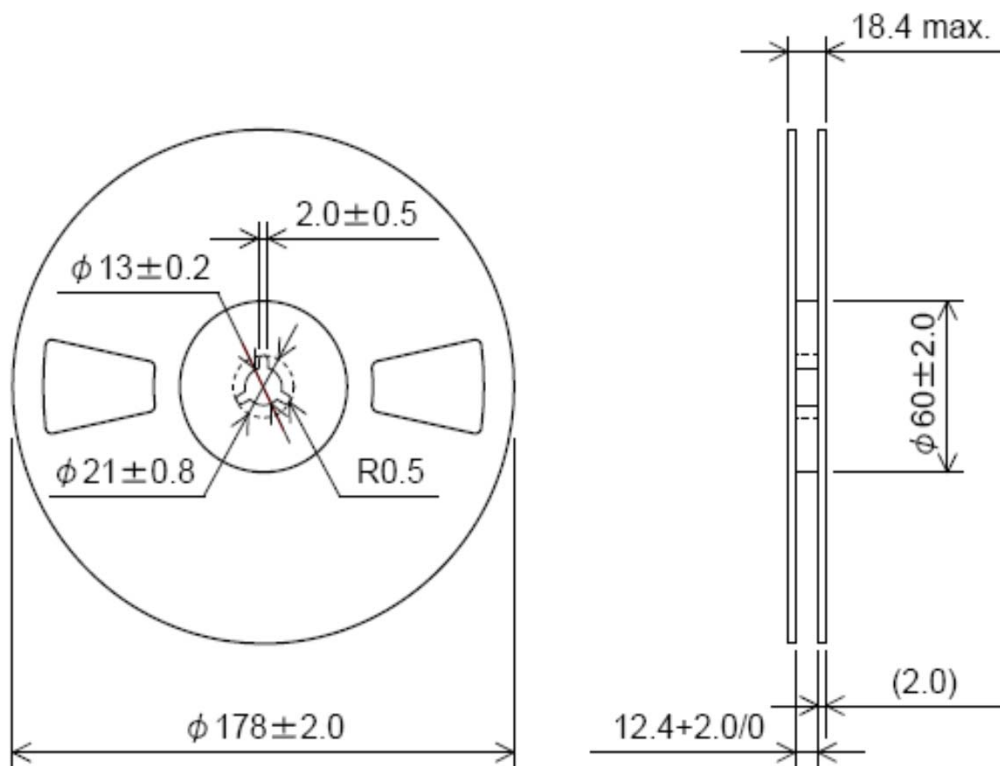

Quantity : 3000pcs / Reel