



Chipsmall Limited consists of a professional team with an average of over 10 year of expertise in the distribution of electronic components. Based in Hongkong, we have already established firm and mutual-benefit business relationships with customers from,Europe,America and south Asia,supplying obsolete and hard-to-find components to meet their specific needs.

With the principle of “Quality Parts,Customers Priority,Honest Operation,and Considerate Service”,our business mainly focus on the distribution of electronic components. Line cards we deal with include Microchip,ALPS,ROHM,Xilinx,Pulse,ON,Everlight and Freescale. Main products comprise IC,Modules,Potentiometer,IC Socket,Relay,Connector.Our parts cover such applications as commercial,industrial, and automotives areas.

We are looking forward to setting up business relationship with you and hope to provide you with the best service and solution. Let us make a better world for our industry!



## Contact us

Tel: +86-755-8981 8866 Fax: +86-755-8427 6832

Email & Skype: info@chipsmall.com Web: www.chipsmall.com

Address: A1208, Overseas Decoration Building, #122 Zhenhua RD., Futian, Shenzhen, China





Part No: GA0876M

Date: 9/26/2006

Unit: mm

Description: speaker

Page No: 1 of 2



### Specifications

Nominal Size	87 mm (3.25 in)	(See attached drawing)
Impedance	8 Ohm $\pm$ 15%	at 800 Hz 1 V
Resonant frequency	260 Hz $\pm$ 52 Hz	at 1 V
Sound pressure level	85 dB/w $\pm$ 3 dB	1 w 50 cm ave. at 0.7K, 0.9K, 1.2K, 1.4K Hz
Response	Fo Hz ~ 22 KHz max 10 dB	
Input power	Nominal 1 W	Handling capacity 3 W
Operation	must be normal at program source 1 W	
Buzz, rattle, etc.	must be normal at sine wave 2.83 V	
Magnet	Size: 13 x 10 mm	
Load test	White noise 1 W	for 5 hours
Heat test	70 $\pm$ 2° C	20-50% R.H. 5 hours
Humidity test	40 $\pm$ 2° C	90-95% R.H. 5 hours

### Frequency Response Curve

Potentiometer range	50 dB
Rectifier	RMS
Lower limit frequency	20 Hz
Wr. speed	100 mm/sec

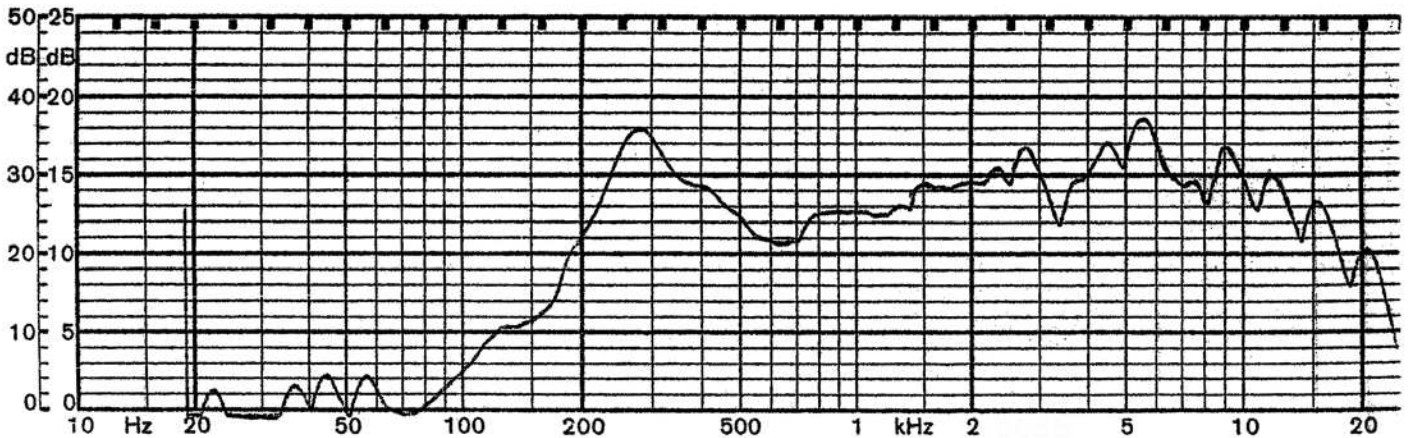

Zero level 60 dB

REV.	DESCRIPTION	DATE
A	NEW DRAWING	9/15/2006

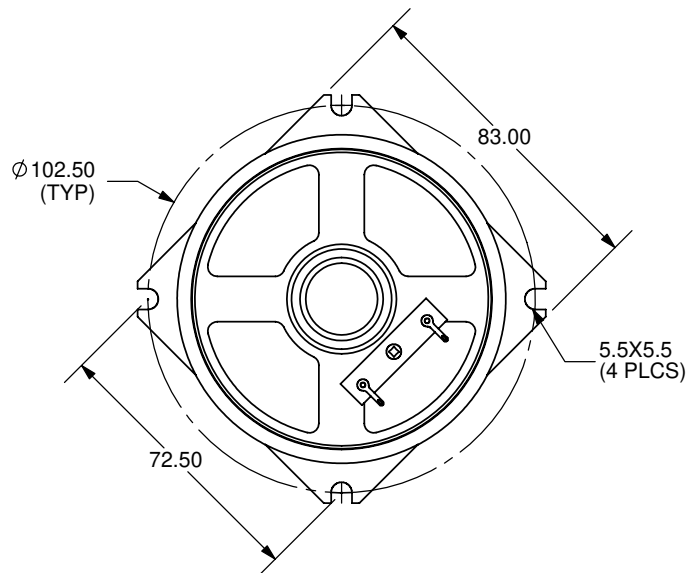
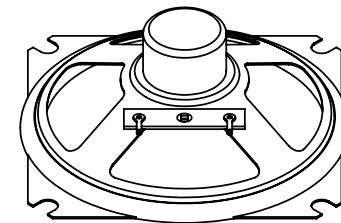
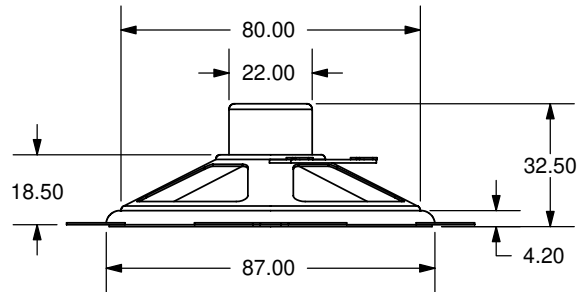

TOLERANCE:  
±0.5mm UNLESS OTHERWISE  
SPECIFIED



20050 SW 112th Ave.  
Tualatin, OR 97062  
Phone: 503-643-4899  
800-275-4899  
Fax: 503-372-1266  
Website: www.cui.com

TITLE: Square frame mylar cone - alnico magnet		REV: A
PART NO. GA0876M	UNITS: MM [INCHES]	
DRAWN BY: ZRJ	APPROVED BY:	SCALE: 1:2

PC FILE NAME:  
GA0876M

COPYRIGHT 2006 BY CUI INC.