



Chipsmall Limited consists of a professional team with an average of over 10 year of expertise in the distribution of electronic components. Based in Hongkong, we have already established firm and mutual-benefit business relationships with customers from,Europe,America and south Asia,supplying obsolete and hard-to-find components to meet their specific needs.

With the principle of "Quality Parts,Customers Priority,Honest Operation,and Considerate Service",our business mainly focus on the distribution of electronic components. Line cards we deal with include Microchip,ALPS,ROHM,Xilinx,Pulse,ON,Everlight and Freescale. Main products comprise IC,Modules,Potentiometer,IC Socket,Relay,Connector.Our parts cover such applications as commercial,industrial, and automotives areas.

We are looking forward to setting up business relationship with you and hope to provide you with the best service and solution. Let us make a better world for our industry!



## Contact us

Tel: +86-755-8981 8866 Fax: +86-755-8427 6832

Email & Skype: info@chipsmall.com Web: www.chipsmall.com

Address: A1208, Overseas Decoration Building, #122 Zhenhua RD., Futian, Shenzhen, China



## Double Pulse Switching Board

$V_{DS, MAX}$	=	1200 V
$I_{D, MAX}$	=	100 A

### Features

- 1200 V, 100 A Testing
- Low Series Inductance Design
- Wide, 6 oz. Copper Current Traces
- Multiple DUT and FWD Connections for Durability
- Low Resistance and Inductance Gate Drive Connection

### Compatible

- SiC Junction Transistors (SJT)
- SiC MOSFETS
- Silicon Power MOSFETS
- Fast Silicon IGBTs

### Electrical Characteristics

Parameter	Symbol	Conditions	Value	Unit	Notes
Test Voltage Maximum	$V_{DS, MAX}$		1200	V	
Drain Current Maximum	$I_{D, MAX}$		100	A	
Capacitor Bank	$C_{bank}$		5.0	$\mu F$	
Parasitic Inductance	$L_s$	$V_{DS} = 800 V, I_D = 6 A$	60	nH	
Maximum Stored Energy	$E_{max}$	$V_{DS} = 1200 V$	3.6	J	

### Overview

The GeneSiC Double Pulse Test Board is designed for performing switching tests on a wide variety of silicon and SiC power transistors. It is designed using low ESL capacitors and PCB traces to have a low parasitic series inductance ( $L_s$ ) current path. This allows recorded data to be most representative of the device under test (DUT) and minimize testing circuit distortions. The board is capable of up to 1200 V and 100 A. User-provided external load inductor, DUT, and free-wheeling diode (FWD) may be soldered directly to the board, without testing sockets, for the lowest possible contact resistance and inductance. A gate drive circuit board may be mounted directly on to the Test Board for a short, low inductance path to the DUT gate pin connection.

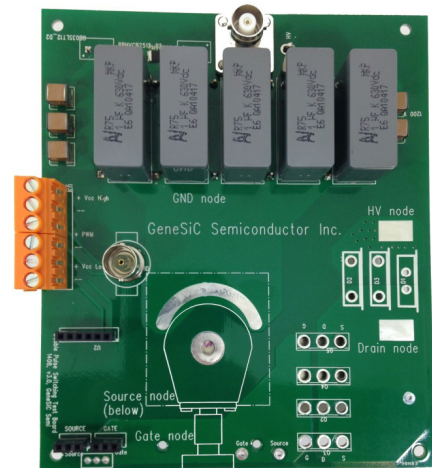

Figure 1: Double Pulse Test Board

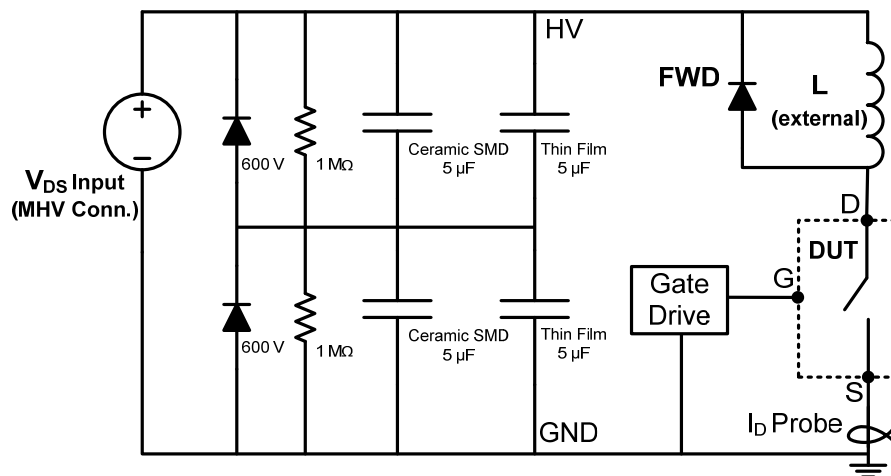

Figure 2: GeneSiC Semiconductor Switching Test Board Schematic



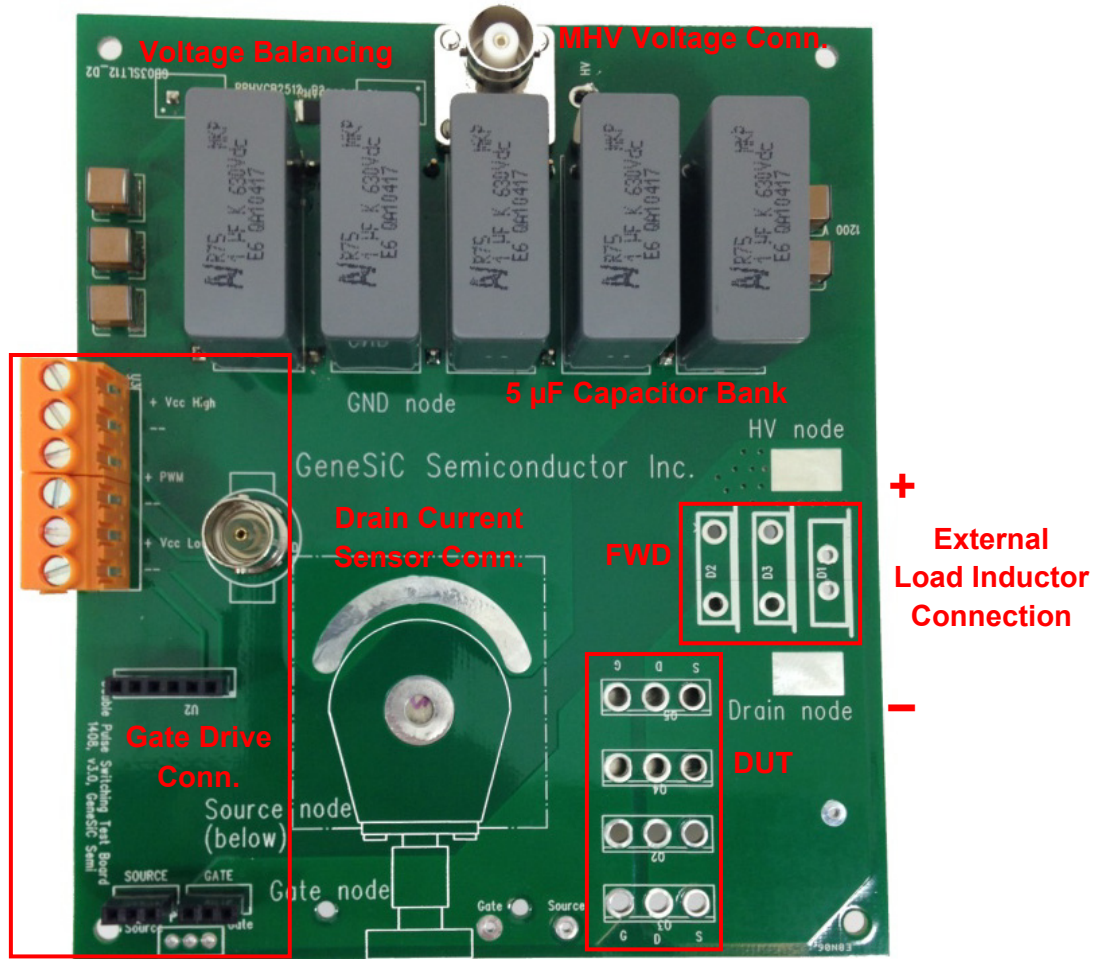

Figure 3: Switching Test Board with Labeling

### MHV Voltage Connection

High voltage for testing up to 1200 V is supplied to the Test Board through a MHV coaxial connection. Voltage may be generated through a high voltage power supply.

### Capacitor Bank

The capacitor bank is comprised of 20, 1 µF, 630 V capacitors to store up to 3.6 J of energy to supply to the DUT. The bank includes 10 low effective series inductance (ESL) surface mount ceramic capacitors to allow DUT drain currents to rise and fall with minimal circuit interference. Copper traces of 6 oz. thickness on the Test Board also minimize parasitic inductance.

### Voltage Balancing Network

A voltage balancing network of two 1 MΩ, 2 W SMD resistors is used to ensure an equal potential is across the series connected capacitors on the Test Board along with two blocking rectifiers to protect against extreme overvoltage of the energy storage capacitors.

### External Load Inductor

A load inductor (not provided) can be soldered directly to the HV and Drain nodes on their provided connection pads. Care should be taken to ensure the voltage rating of the inductor is not exceeded. Also, if the chosen inductor value is too large the capacitor bank may discharge before the inductor is fully charged to the desired test current  $I_D$  level during double pulse testing. An inductance of  $L_{load} \leq 1.0$  mH is suggested.

### Device Under Test (DUT) and Free Wheeling Diode (FWD)

The DUT and FWD should be soldered into the connection terminals with minimal extra lead length. Leads extending through the Test Board should be trimmed from the package to reduce electrical noise which may distort measurement during ultra-fast, high-voltage switching. Devices may be connected to isolated hotplates while connected to the Test Board for high-temperature testing as desired. It is also recommended to probe any device voltages (i.e.  $V_{GS}$ ,  $V_{DS}$ ) as close as possible to the device for accurate measurement and minimal testing induced voltage and current ringing.

### Drain Current Sensor Connection

A low inductance measurement of the DUT drain current can be made utilizing the drain current sensor connection along with the use of a Pearson Electronics Current Monitor (shape “F”, not provided). The connection can best be made utilizing a wide metallic conductor extending from the GND node partially encasing the current monitor with a wide conductor extending through the current monitor eye-hole and connecting to the source node beneath. These two nodes, source and GND, must be connected for the Test Board to operate properly and when used in this configuration the drain current passed through a current monitor for data recording while adding minimal parasitic inductance. If the drain current is not being sensed at the Drain Current Sensor Connection the two nodes must be shorted together using a wide jumper cable.

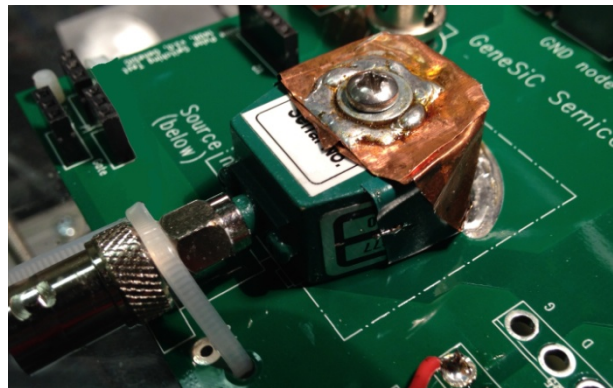

Figure 4: Drain Current Sensor Connection with Pearson Current Monitor installed using a low inductance current path.

### Gate Drive Connection

The Gate Drive Connection may be used to connect a gate drive board to the Test Board and DUT. It is designed to receive the gate drive board voltage inputs from an external supply as well as the digital gate control signal and pass them through the Test Board to the gate drive board inputs through a 6 pin, in-line header connection. The output gate connection of the gate drive board is directly fed into the Test Board gate node through a 3 pin header and is passed with a low parasitic inductance connection to the DUT gate pin along with a similar source connection return. The use of the Gate Drive Connection is optional and DUT gate driving is fully customizable to the users' specifications and preferences. The connection of any gate drive topology may be made to the Gate Drive Connection or directly to the DUT.

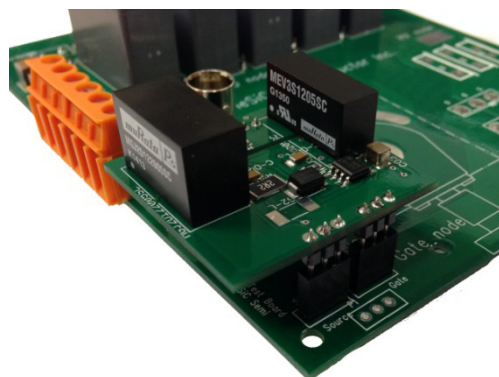

Figure 5: GeneSiC Gate Drive Board (GA03IDDJT30-FR4) connected to the Test Board's Gate Drive Connection

## Example Capability Switching Waveforms

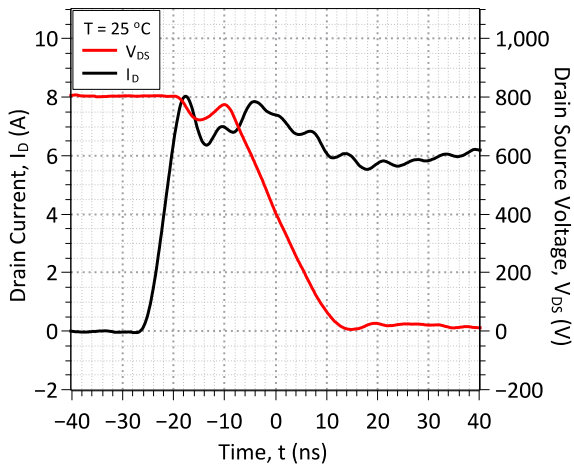

Figure 6: SJT 800V Switching Turn On Waveform

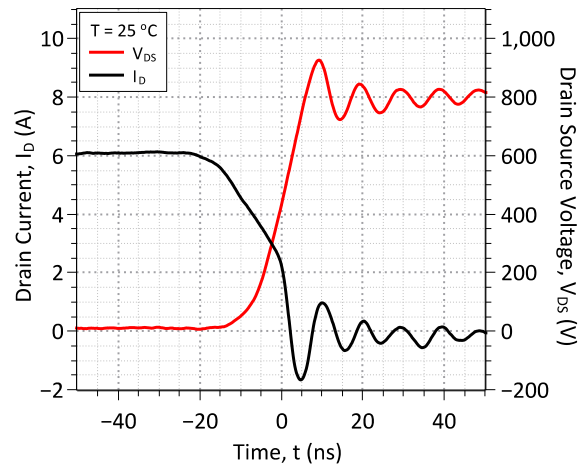

Figure 7: SJT 800V Switching Turn Off Waveform

Table 1: Bill of Materials

#ITEM	Designator	Description	Package (Metric)	Manufacturer	Manufacturer Part Number	Quantity / Board
1	C1, C2, C3, C4, C5, C6, C7, C8, C9, C10	Capacitor, Film, 1 $\mu$ F, 630V, Radial	Through Hole	Kemet	R75PR4100AA30K	10
2	C11, C12, C13, C14, C15, C16, C17, C18, C19, C20	Capacitor, Ceramic, 1 $\mu$ F, 630V, X7T, SMD	Stacked SMD	TDK Corp	CKG57NX7T2J105M500JH	10
3	R1, R2	Resistor, 1 M $\Omega$ , 2W, 1%, 2512, SMD	6432	TE Connectivity	2-2176071-2	2
4	D6, D7	Silicon Diode, Ultra Fast, 1.2 kV, 5A,	TO-220	STMicroelectronics	STTH512D	2
5	U1	Connector, BNC MHV Jack	Through Hole	Amphenol	000-27000	1
6	U2	Connector, Header 0.100IN, Female, 6POS, Vertical	Through Hole	Sullins Connector	PPTC061LFBN-RC	1
7	GATE, SOURCE	Connector, Header 0.100IN, Female, 3POS, Vertical	Through Hole	Sullins Connector	PPTC031LFBN-RC	2
8	U3	Terminal Block, 6POS, Side Entry, 5.08 mm	Through Hole	TE Connectivity	282837-6	1
9	U4	Connector, BNC Jack, 50 $\Omega$	Through Hole	TE Connectivity	5-1634503-1	1
10	DUT	Device Under Test			Not Provided	1
11	FWD	Free Wheeling Diode			Not Provided	1
12	U5	Drain Current Sensor	Pearson Shape "F"		Not Provided	1
13	IL	Load Inductor			Not Provided	1

**Revision History**

Date	Revision	Comments	Supersedes
2015/09/11	2	Updated Characteristics	
2015/03/20	1	Updated Characteristics	
2014/09/15	0	Initial release	

Published by  
GeneSiC Semiconductor, Inc.  
43670 Trade Center Place Suite 155  
Dulles, VA 20166

GeneSiC Semiconductor, Inc. reserves right to make changes to the product specifications and data in this document without notice.

GeneSiC disclaims all and any warranty and liability arising out of use or application of any product. No license, express or implied to any intellectual property rights is granted by this document.

Unless otherwise expressly indicated, GeneSiC products are not designed, tested or authorized for use in life-saving, medical, aircraft navigation, communication, air traffic control and weapons systems, nor in applications where their failure may result in death, personal injury and/or property damage.