



Chipsmall Limited consists of a professional team with an average of over 10 year of expertise in the distribution of electronic components. Based in Hongkong, we have already established firm and mutual-benefit business relationships with customers from,Europe,America and south Asia,supplying obsolete and hard-to-find components to meet their specific needs.

With the principle of "Quality Parts,Customers Priority,Honest Operation,and Considerate Service",our business mainly focus on the distribution of electronic components. Line cards we deal with include Microchip,ALPS,ROHM,Xilinx,Pulse,ON,Everlight and Freescale. Main products comprise IC,Modules,Potentiometer,IC Socket,Relay,Connector.Our parts cover such applications as commercial,industrial, and automotives areas.

We are looking forward to setting up business relationship with you and hope to provide you with the best service and solution. Let us make a better world for our industry!



## Contact us

Tel: +86-755-8981 8866 Fax: +86-755-8427 6832

Email & Skype: info@chipsmall.com Web: www.chipsmall.com

Address: A1208, Overseas Decoration Building, #122 Zhenhua RD., Futian, Shenzhen, China



# Fast Recovery Epitaxial Diode (FRED)

$I_{FAV} = 8 \text{ A}$   
 $V_{RRM} = 600 \text{ V}$   
 $t_{rr} = 35 \text{ ns}$

$V_{RSM}$	$V_{RRM}$	Type
V	V	
640	600	DSEI 8-06A
640	600	DSEI 8-06AS

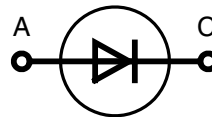
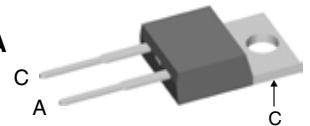
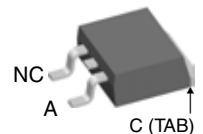
**TO-220 AC**  
**DSEI 8-06A**

**TO-263 AB**  
**DSEI 8-06AS**

A = Anode, C = Cathode,  
 NC = No Connection,  
 TAB = Cathode

Symbol	Conditions	Maximum Ratings		
$I_{FRMS}$	$T_{VJ} = T_{VJM}$	16	A	
$I_{FAVM}$ ①	$T_C = 115^\circ\text{C}$ ; rectangular, $d = 0.5$	8	A	
$I_{FRM}$	$t_p < 10 \mu\text{s}$ ; rep. rating, pulse width limited by $T_{VJM}$	130	A	
$I_{FSM}$	$T_{VJ} = 45^\circ\text{C}$ ;	$t = 10 \text{ ms}$ (50 Hz), sine	100	A
		$t = 8.3 \text{ ms}$ (60 Hz), sine	110	
	$T_{VJ} = 150^\circ\text{C}$ ;	$t = 10 \text{ ms}$ (50 Hz), sine	85	A
		$t = 8.3 \text{ ms}$ (60 Hz), sine	95	
$I^2t$	$T_{VJ} = 45^\circ\text{C}$ ;	$t = 10 \text{ ms}$ (50 Hz), sine	50	$\text{A}^2\text{s}$
		$t = 8.3 \text{ ms}$ (60 Hz), sine	50	
	$T_{VJ} = 150^\circ\text{C}$ ;	$t = 10 \text{ ms}$ (50 Hz), sine	36	$\text{A}^2\text{s}$
		$t = 8.3 \text{ ms}$ (60 Hz), sine	37	
$T_{VJ}$		-40...+150	$^\circ\text{C}$	
$T_{VJM}$		150	$^\circ\text{C}$	
$T_{stg}$		-40...+150	$^\circ\text{C}$	
$P_{tot}$	$T_C = 25^\circ\text{C}$	50	W	
$M_d$	mounting torque	0.4...0.6	Nm	
Weight	typical	2	g	

## Features

- International standard package JEDEC TO-220 AC & TO-283 AB
- Planar passivated chips
- Very short recovery time
- Extremely low switching losses
- Low  $I_{RM}$ -values
- Soft recovery behaviour
- Epoxy meets UL 94V-0

## Applications

- Antiparallel diode for high frequency switching devices
- Anti saturation diode
- Snubber diode
- Free wheeling diode in converters and motor control circuits
- Rectifiers in switch mode power supplies (SMPS)
- Inductive heating and melting
- Uninterruptible power supplies (UPS)
- Ultrasonic cleaners and welders

## Advantages

- High reliability circuit operation
- Low voltage peaks for reduced protection circuits
- Low noise switching
- Low losses
- Operating at lower temperature or space saving by reduced cooling

Symbol	Conditions	Characteristic Values		
		typ.	max.	
$I_R$	$V_R = V_{RRM}$	$T_{VJ} = 25^\circ\text{C}$	20	$\mu\text{A}$
	$V_R = 0.8 \cdot V_{RRM}$	$T_{VJ} = 25^\circ\text{C}$	10	$\mu\text{A}$
	$V_R = 0.8 \cdot V_{RRM}$	$T_{VJ} = 125^\circ\text{C}$	1.5	mA
$V_F$	$I_F = 8 \text{ A}$	$T_{VJ} = 150^\circ\text{C}$	1.3	V
		$T_{VJ} = 25^\circ\text{C}$	1.5	V
$V_{T0}$	For power-loss calculations only		0.98	V
$r_T$	$T_{VJ} = T_{VJM}$		28.7	$\text{m}\Omega$
$R_{thJC}$			2.5	K/W
$R_{thCH}$		0.5		K/W
$R_{thJA}$			60	K/W
$t_{rr}$	$I_F = 1 \text{ A}$ ; $-di/dt = 50 \text{ A}/\mu\text{s}$ ; $V_R = 30 \text{ V}$ ; $T_{VJ} = 25^\circ\text{C}$	35	50	ns
$I_{RM}$	$V_R = 350 \text{ V}$ ; $I_F = 8 \text{ A}$ ; $-di_F/dt = 64 \text{ A}/\mu\text{s}$ $L \leq 0.05 \mu\text{H}$ ; $T_{VJ} = 100^\circ\text{C}$	2.5	2.8	A

①  $I_{FAVM}$  rating includes reverse blocking losses at  $T_{VJM}$ .  $V_R = 0.8 \cdot V_{RRM}$ , duty cycle  $d = 0.5$   
 Data according to IEC 60747

IXYS reserves the right to change limits, test conditions and dimensions.

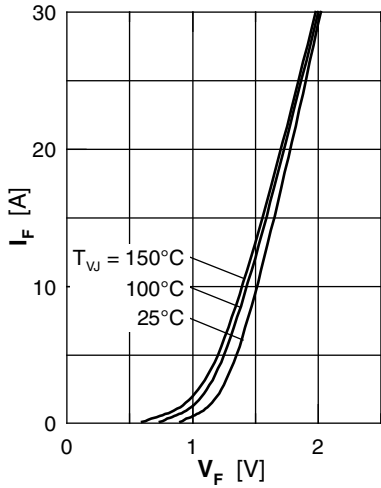

Fig. 1 Forward current versus voltage drop

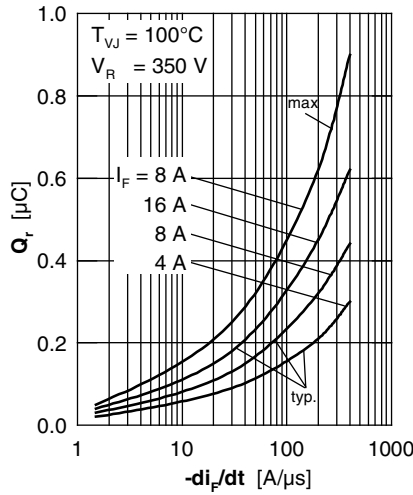

Fig. 2 Recovery charge versus  $-di_F/dt$

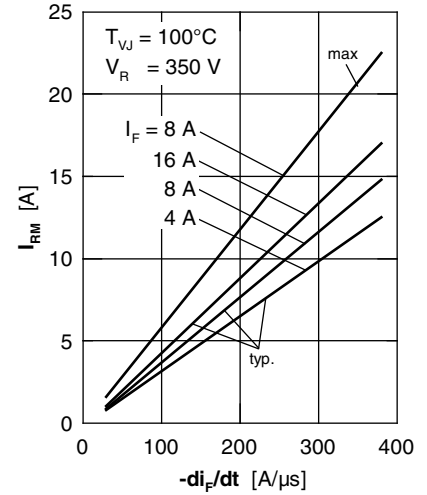

Fig. 3 Peak reverse current versus  $-di_F/dt$

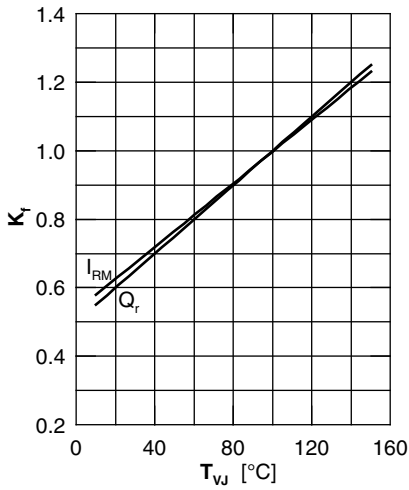

Fig. 4 Dynamic parameters versus junction temperature

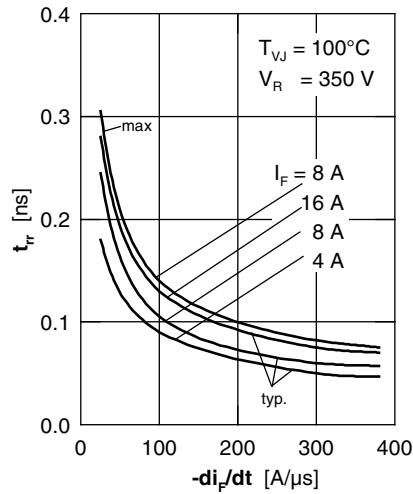

Fig. 5 Recovery time versus  $-di_F/dt$

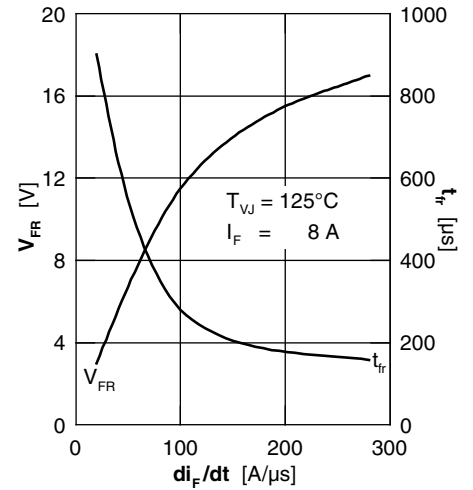

Fig. 6 Peak forward voltage versus  $di_F/dt$

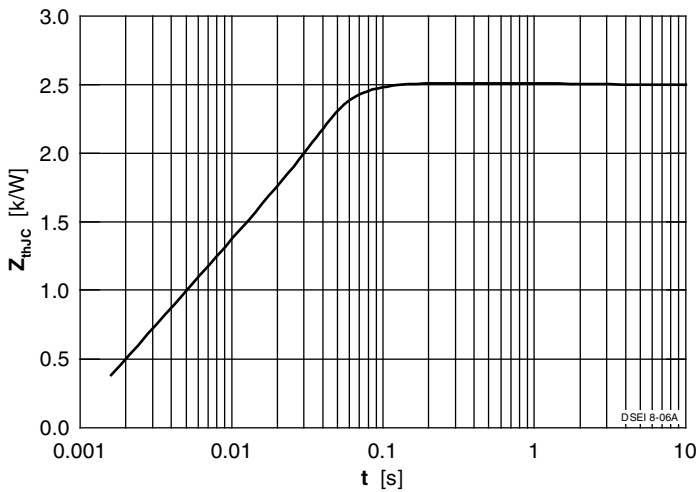
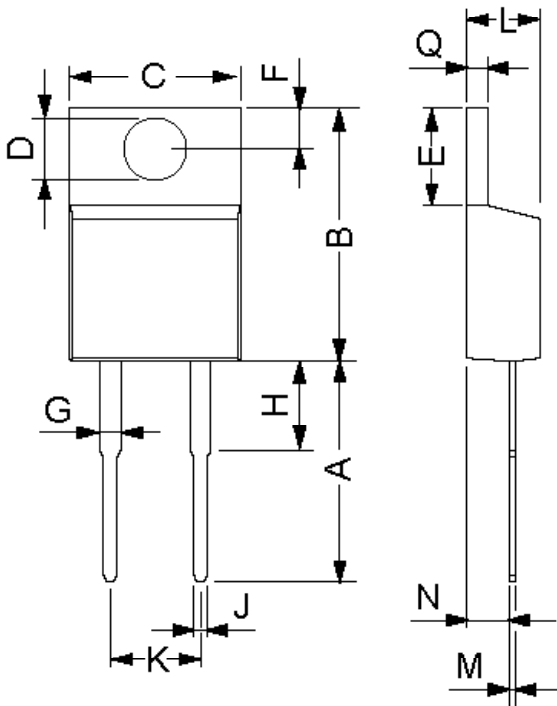

Fig. 7 Transient thermal resistance junction to case

## Dimensions TO-220 AC



Dim.	Millimeter		Inches	
	Min.	Max.	Min.	Max.
A	12.7	14.73	0.5	0.58
B	14.23	16.51	0.56	0.65
C	9.66	10.66	0.38	0.42
D	3.54	4.08	0.139	0.161
E	5.85	6.85	2.3	0.42
F	2.54	3.42	0.1	0.135
G	1.15	1.77	0.045	0.07
H	-	6.35	-	0.25
J	0.64	0.89	0.025	0.035
K	4.83	5.33	0.19	0.21
L	3.56	4.82	0.14	0.19
M	0.51	0.76	0.02	0.03
N	2.04	2.49	0.08	0.115
Q	0.64	1.39	0.025	0.055

## Dimensions TO-263 AB

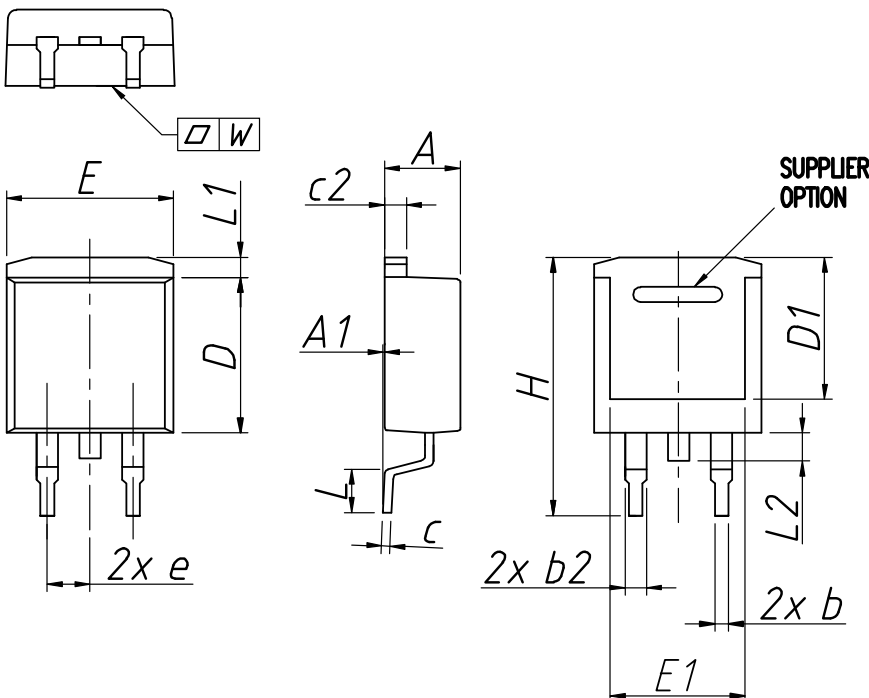

Dim.	Millimeter		Inches	
	min	max	min	max
A	4.06	4.83	0.160	0.190
A1	typ. 0.10		typ. 0.004	
b	0.51	0.99	0.020	0.039
b2	1.14	1.40	0.045	0.055
c	0.40	0.74	0.016	0.029
c2	1.14	1.40	0.045	0.029
D	8.38	9.40	0.330	0.370
D1	8.00	8.89	0.315	0.350
E	9.65	10.41	0.380	0.410
E1	6.22	8.13	0.245	0.320
e	2,54 BSC		0,100 BSC	
H	14.61	15.88	0.575	0.625
L	1.78	2.79	0.070	0.110
L1	1.02	1.68	0.040	0.066
L2	1.02	1.52	0.040	0.060
W	typ. 0.02	0.040	typ. 0.0008	0.0016

All dimensions conform with and/or are within JEDEC standard.