



Chipsmall Limited consists of a professional team with an average of over 10 year of expertise in the distribution of electronic components. Based in Hongkong, we have already established firm and mutual-benefit business relationships with customers from,Europe,America and south Asia,supplying obsolete and hard-to-find components to meet their specific needs.

With the principle of “Quality Parts,Customers Priority,Honest Operation,and Considerate Service”,our business mainly focus on the distribution of electronic components. Line cards we deal with include Microchip,ALPS,ROHM,Xilinx,Pulse,ON,Everlight and Freescale. Main products comprise IC,Modules,Potentiometer,IC Socket,Relay,Connector.Our parts cover such applications as commercial,industrial, and automotives areas.

We are looking forward to setting up business relationship with you and hope to provide you with the best service and solution. Let us make a better world for our industry!



## Contact us

Tel: +86-755-8981 8866 Fax: +86-755-8427 6832

Email & Skype: info@chipsmall.com Web: www.chipsmall.com

Address: A1208, Overseas Decoration Building, #122 Zhenhua RD., Futian, Shenzhen, China



## MODEL GCM422 - SERIAL CONVERTER MODULE [RS422/20 mA current loop]



- ALLOWS COMMUNICATIONS BETWEEN RS422 CONTROL EQUIPMENT AND RLC PRODUCTS WITH 20 mA SERIAL COMMUNICATIONS OPTION
- TRANSMIT DISABLE ALLOWS OPERATION ON A TWO-WIRE BUS FOR RS485 COMPATIBILITY
- ISOLATED 20 mA SERIAL COMMUNICATIONS
- FULLY ENCLOSED SCREW TOGETHER DURABLE PLASTIC CASE



### DESCRIPTION

The GCM422 Serial Converter Module provides the capability of interfacing Red Lion Controls products, with 20 mA current loop serial communications option, to any equipment with RS-422 communications. The isolated 20 mA current loop connections in the GCM422 allow multiple modules to be wired into the serial loop. Data format of the RS-422 equipment must be the same as the Red Lion Controls product (Reference the serial communications section of the appropriate manual for more details). The GCM422 module can be made to interface with RS-485 equipment by repositioning an internal jumper (which is a removable plug type arrangement). (The user must supply a method of electrically selecting the transmit disable input.)

An external power source is required to power the GCM422 module. Some Red Lion Controls products have a +12 VDC output which can be used. (Note: Reference appropriate manual to ensure +12 VDC output has enough current capability.) The external power source and isolated 20 mA serial communications loop connections are made via a 6 position terminal block located inside the module. A 680Ω current limiting resistor is provided to obtain the source current for the Serial Current Loop. Connections for the RS-422 or RS-485 are made via a 25 pin female D-type connector.

### SAFETY SUMMARY

All safety related regulations, local codes and instructions that appear in the manual or on equipment must be observed to ensure personal safety and to prevent damage to either the instrument or equipment connected to it. If equipment is used in a manner not specified by the manufacturer, the protection provided by the equipment may be impaired.

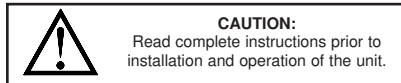

### SPECIFICATIONS

1. **POWER:** +9 to 26 VDC @ 50 mA max. Power supplies must be Class 2 or SELV rated.
2. **RS-422 VOLTAGES:**
  - Differential output voltage (pins 2 & 14):** ±5 VDC<sub>max.</sub> under no load condition.
  - Differential input voltage (pins 3 & 16):** ±5 VDC<sub>max.</sub>
  - mark condition** = ≤ -0.2 VDC
  - space condition** = ≥ 0.2 VDC
  - Common mode input voltage:** -7 VDC to +12 VDC.
3. **RS-485 TRANSMIT DISABLE INPUT (Pin 4):**
  - Active low  $V_{IL} = 0.8 \text{ VDC}_{max.}$
  - Internally pulled up to +5 VDC through 3.3 KΩ resistor.
4. **RS-422 DRIVE CAPACITY:** Up to 32 RS-422 receivers connected in parallel.

#### 5. 20 mA CURRENT LOOP:

**SO - Output Transistor Rating:**  $V_{max} = 25 \text{ VDC}$ ,

$V_{sat} = 1 \text{ VDC}_{max} @ 20 \text{ mA}$ .

**SI - Input Diode Rating:**  $V_F = 1.25 \text{ VDC}_{typ}$ ,  $1.5 \text{ VDC}_{max} @ 20 \text{ mA}$ .

(Note: Reverse polarity protection at SI diode)

#### 6. MAXIMUM CABLE LENGTH:

**RS-422 or RS-485 cable:** 4000 Ft.

**20 mA current loop:** 4000 Ft.

#### 7. BAUD RATE:

9600 Baud max.

#### 8. ENVIRONMENTAL CONDITIONS:

**Operating Temperature:** 0 to 50°C

**Storage Temperature:** -40 to 80°C

**Operating and Storage Humidity:** 85% max. relative humidity (non-condensing) from 0°C to 50°C.

**Altitude:** Up to 2000 meters

#### 9. CERTIFICATIONS AND COMPLIANCES:

##### SAFETY

IEC 1010-1, EN 61010-1: Safety requirements for electrical equipment for measurement, control, and laboratory use, Part 1.

##### EMC EMISSIONS:

Meets EN50081-1: Residential, Commercial and Light Industry

CISPR 22 Radiated and conducted emissions

##### EMC IMMUNITY:

Meets EN 50082-2: Industrial Environment.

ENV 50140 - Radio-frequency radiated electromagnetic field <sup>1</sup>

ENV 50141 - Radio-frequency conducted electromagnetic field <sup>1</sup>

EN 61000-4-2 - Electrostatic discharge (ESD)<sup>2</sup>

EN 61000-4-4 - Electrical fast transient/burst (EFT)<sup>3</sup>

##### Notes:

1. For operation without loss of performance:  
 Install power line filter, RLC #LFIL0000 or equivalent.  
 I/O cables routed in metal conduit connected to earth ground.
2. Anti-static precautions should be observed before handling the device.
3. For operation without loss of performance:  
 Install power line filter, RLC #LFIL0000 or equivalent.

Refer to EMC Installation Guidelines section of the manual for additional information.

#### 10. DIMENSIONS:

0.99" (25.2 mm) H x 2.10" (53.4 mm) W x 4.32" (109.8 mm) L

11. Shielded cable must be used, connect shield drain wire to earth ground.

(Note: RS-485 Specifications are the same as RS-422)

### ORDERING INFORMATION

MODEL NO.	DESCRIPTION	PART NUMBER
GCM422	Serial Converter Module RS422	GCM42201

## EMC INSTALLATION GUIDELINES

Although this unit is designed with a high degree of immunity to ElectroMagnetic Interference (EMI), proper installation and wiring methods must be followed to ensure compatibility in each application. The type of electrical noise, source or coupling method into the unit may be different for various installations. In extremely high EMI environments, additional measures may be needed. Cable length, routing and shield termination are very important and can mean the difference between a successful or a troublesome installation. Listed below are some EMC guidelines for successful installation in an industrial environment.

1. DC power to the unit should be relatively clean and within the specified limits. Connecting power to the unit from circuits that power inductive loads that cycle on and off, such as contactors, relays, motors, etc., should be avoided. This will reduce the chance of noise spikes entering the DC power connection and affecting the unit.
2. The shield (screen) pigtail connection should be made as short as possible. The connection point for the shield depends somewhat upon the application. Listed below are the recommended methods of connecting the shield, in order of their effectiveness.
  - a. Connect the shield only at the unit to earth ground (protective earth).
  - b. Connect the shield to earth ground at both ends of the cable, usually when the noise source frequency is above 1 MHz.
  - c. Connect the shield to common of the unit and leave the other end of the shield unconnected and insulated from earth ground.
3. Never run Signal cables in the same conduit or raceway with AC power lines, conductors feeding motors, solenoids, SCR controls, and heaters, etc. The cables should be run in metal conduit that is properly grounded. This is especially useful in applications where cable runs are long and portable two-way radios are used in close proximity or if the installation is near a commercial radio transmitter.
4. Signal cables within an enclosure should be routed as far away as possible from contactors, control relays, transformers, and other noisy components.
5. In extremely high EMI environments, the use of external EMI suppression devices, such as ferrite suppression cores, is effective. Install them on Signal cables as close to the unit as possible. Loop the cable through the core several times or use multiple cores on each cable for additional protection. Install line filters on the power input cable to the unit to suppress power line interference. Install them near the power entry point of the enclosure. The following EMI suppression devices (or equivalent) are recommended:
  - Ferrite Suppression Cores for signal cables:
    - Fair-Rite # 0443167251 (RLC #FCOR0000)
    - TDK # ZCAT3035-1330A
    - Steward #28B2029-0A0
  - Line Filters for input power cables:
    - Schaffner # FN610-1/07 (RLC #LFIL0000)
    - Schaffner # FN670-1.8/07
    - Corcom #1VR3

*Note: Reference manufacturer's instructions when installing a line filter.*
6. Long cable runs are more susceptible to EMI pickup than short cable runs. Therefore, keep cable runs as short as possible.

## INSTALLATION ENVIRONMENT

The unit should be installed in a location that does not exceed the maximum operating temperature and provides good air circulation. Placing the unit near devices that generate excessive heat should be avoided.

## INSTALLATION

The power and 20 mA current loop connections should be made with 24 gauge, multi-conductor, shielded cable. Wire insulation should be stripped to approximately 1/4 inch (stranded wires should be tinned with solder). Accessing the terminal block and jumper is accomplished by removing the four screws and nuts that hold the two case halves together. If the jumper needs to be re-positioned, it should be done with NO power applied to the module (module is shipped from factory in the 422 position). Connect the power and 20 mA loop wires to the appropriate terminal block pins. The cable is then routed through the groove at the rear of the module. Install the two screws and saddle washers into the slots at the 25 pin D-connector. Position the two case halves together, and secure with the four screws and nuts. Refer to figure 1 below for assembly.

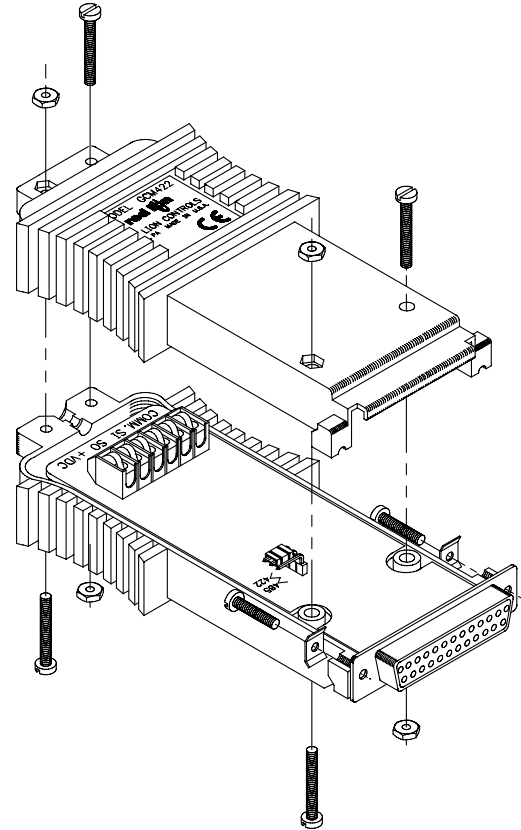

FIGURE 1

## TYPICAL POWER AND 20 mA LOOP CONNECTIONS

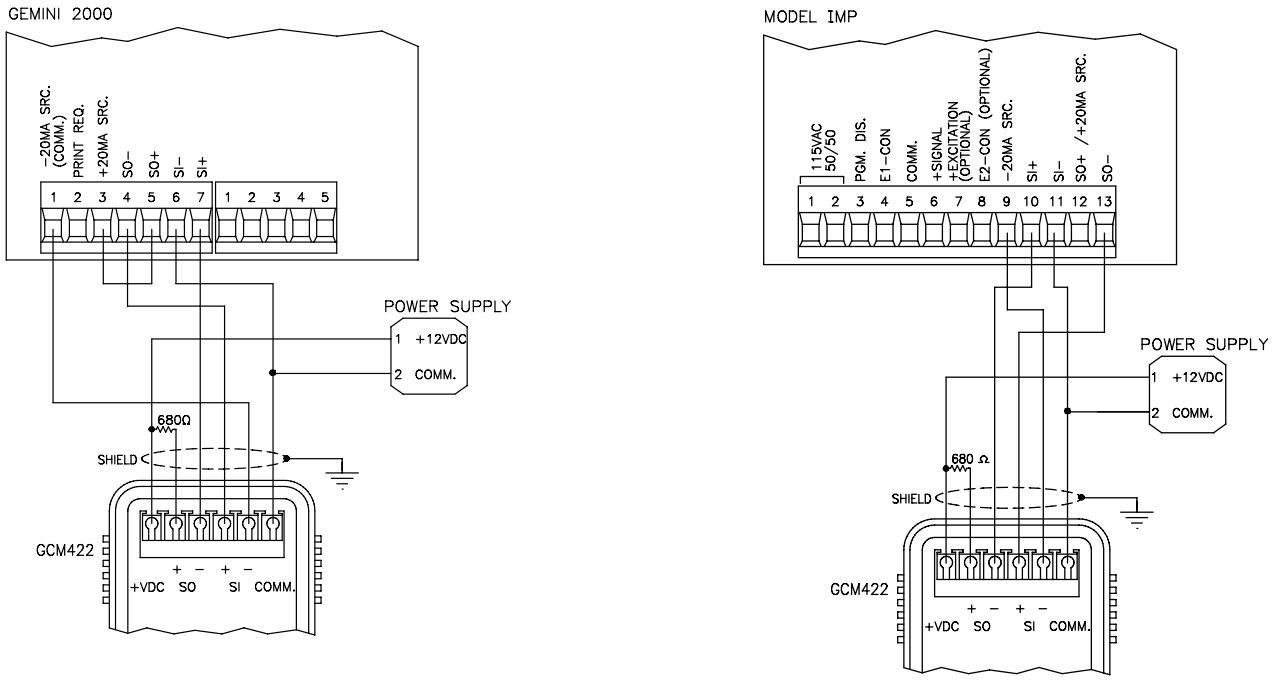

FIGURE 2

## TYPICAL CONNECTION FOR MULTIPLE UNITS

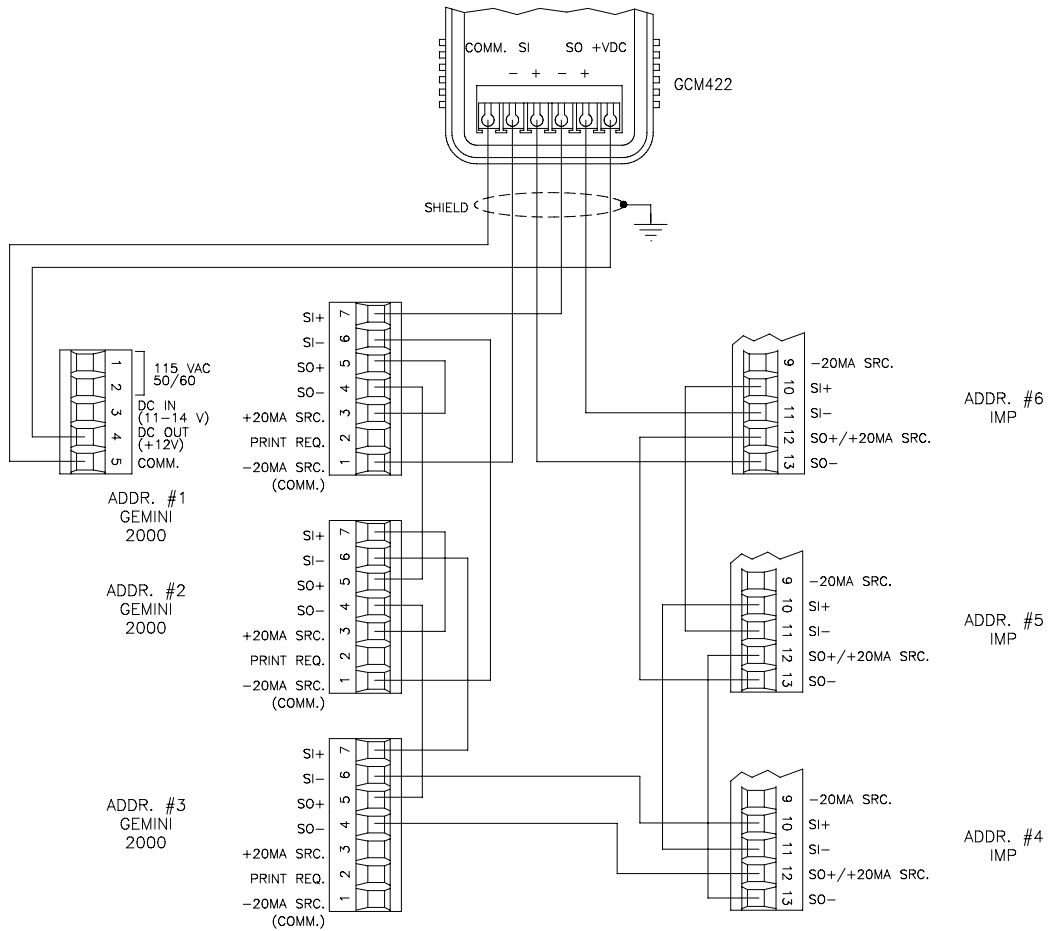
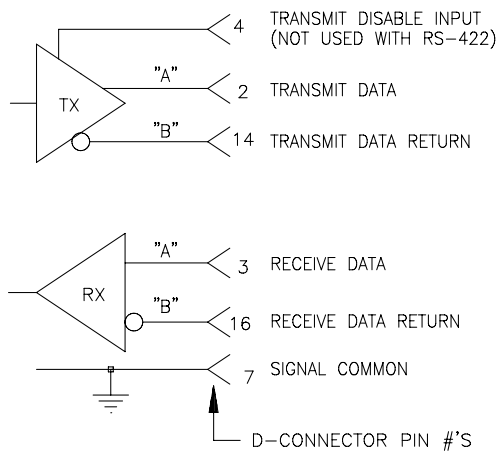

FIGURE 3

## TYPICAL RS-422 CONNECTIONS



### NOTES:

1. Connect shield drain wire to earth ground.
2. RS-422 polarity: Terminal "A" is negative with respect to terminal "B" in the mark (logic 1) condition.
3. If the RS-422 receive data inputs are not connected, the 20 mA SO output will be indeterminate. Therefore if the receive data input is not connected, the 20 mA SI input loop on the Red Lion Controls product must be wired for the mark condition (current flowing) and must be disconnected from the SO output terminals on the GCM422 Module.
4. Current flowing is a stop bit (mark) and no current flowing is a start bit (space).

FIGURE 4

## TYPICAL RS-485 CONNECTIONS

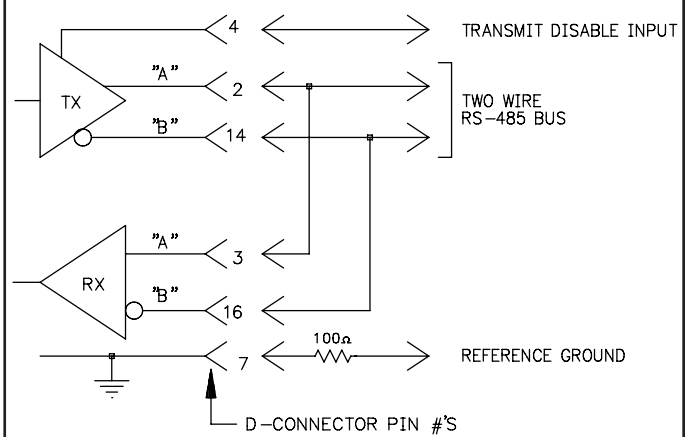

*Note: Connect shield drain wire to earth ground.*

For RS-485 operation, place the internal jumper in the 485 position. The transmit and receive data lines of the GCM422 module should be wired together. The transmit disable input must be high (+ 5 VDC) in order to transmit data from the module (*Note: This input is internally pulled high*). To receive data from an RS-485 device, the transmit disable input must be low which forces the transmit data output into a high impedance state, effectively disconnecting it from the two-wire bus.

Current flowing is a stop bit (mark) and no current flowing is a start bit (space).

FIGURE 5

## TYPICAL RS-485 TO LEGEND CONNECTION

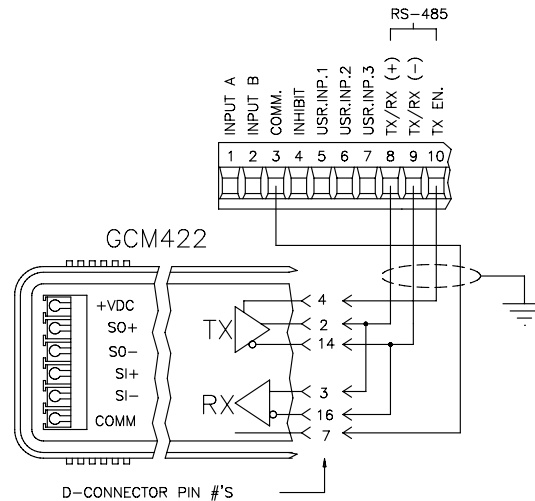

FIGURE 6

## TROUBLESHOOTING

For further technical assistance, contact technical support at the appropriate company numbers listed.