



Chipsmall Limited consists of a professional team with an average of over 10 year of expertise in the distribution of electronic components. Based in Hongkong, we have already established firm and mutual-benefit business relationships with customers from,Europe,America and south Asia,supplying obsolete and hard-to-find components to meet their specific needs.

With the principle of “Quality Parts,Customers Priority,Honest Operation,and Considerate Service”,our business mainly focus on the distribution of electronic components. Line cards we deal with include Microchip,ALPS,ROHM,Xilinx,Pulse,ON,Everlight and Freescale. Main products comprise IC,Modules,Potentiometer,IC Socket,Relay,Connector.Our parts cover such applications as commercial,industrial, and automotives areas.

We are looking forward to setting up business relationship with you and hope to provide you with the best service and solution. Let us make a better world for our industry!



Contact us

Tel: +86-755-8981 8866 Fax: +86-755-8427 6832

Email & Skype: info@chipsmall.com Web: www.chipsmall.com

Address: A1208, Overseas Decoration Building, #122 Zhenhua RD., Futian, Shenzhen, China



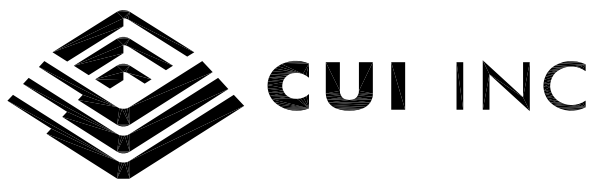

Specifications

1	Part No.	GF1207			
2	Nominal Size	120 mm.	5"	inch	
3	Impedance	$8 \Omega \pm 15\%$	at	600 Hz.	1 V.
4	Resonance	160 Hz. \pm 32 Hz.	FO Hz.	1 V.	
5	S.P. Level	96 dB/w \pm 2 dB	1 w.	50 cm.	average at
6	Response	fo Hz. \sim 8K Hz.	MAX 10dB	500, 600, 800, 1K Hz.	
7	Crossover Freq.	Hz.	Hz.	dB/OCT	Net work
8	Input Power	Nominal Input	5 w.	Handling Capacity	10 w.
9	Operation	Must be normal at program source			5 w.
10	Buzz, Rattle, etc.	Must be normal at sine wave			6.3 v.
11	Flux Density	Gauss \pm 10%			
12	Total Flux	Max well min			
13	Magnet	Size	60 x 32 x 8 mm	gr	oz
14	Total Weight	gr oz			
15	Load Test	After test meet item 9 and 10	White noise	5 w.	48 Hours
16	Distortion	% MAX		Hz	W.
17	Heat Test	After test meet item 9 and 10	70 \pm 2 \pm °C	20-50 %R.H.	48 Hours
18	Humidity Test	After test meet item 9 and 10	40 \pm 2 \pm °C	90-95 %R.H.	48 Hours

PART NO.	GF1207	UNITS:	mm
DRAWN BY:		PAGE NO:	1 of 2

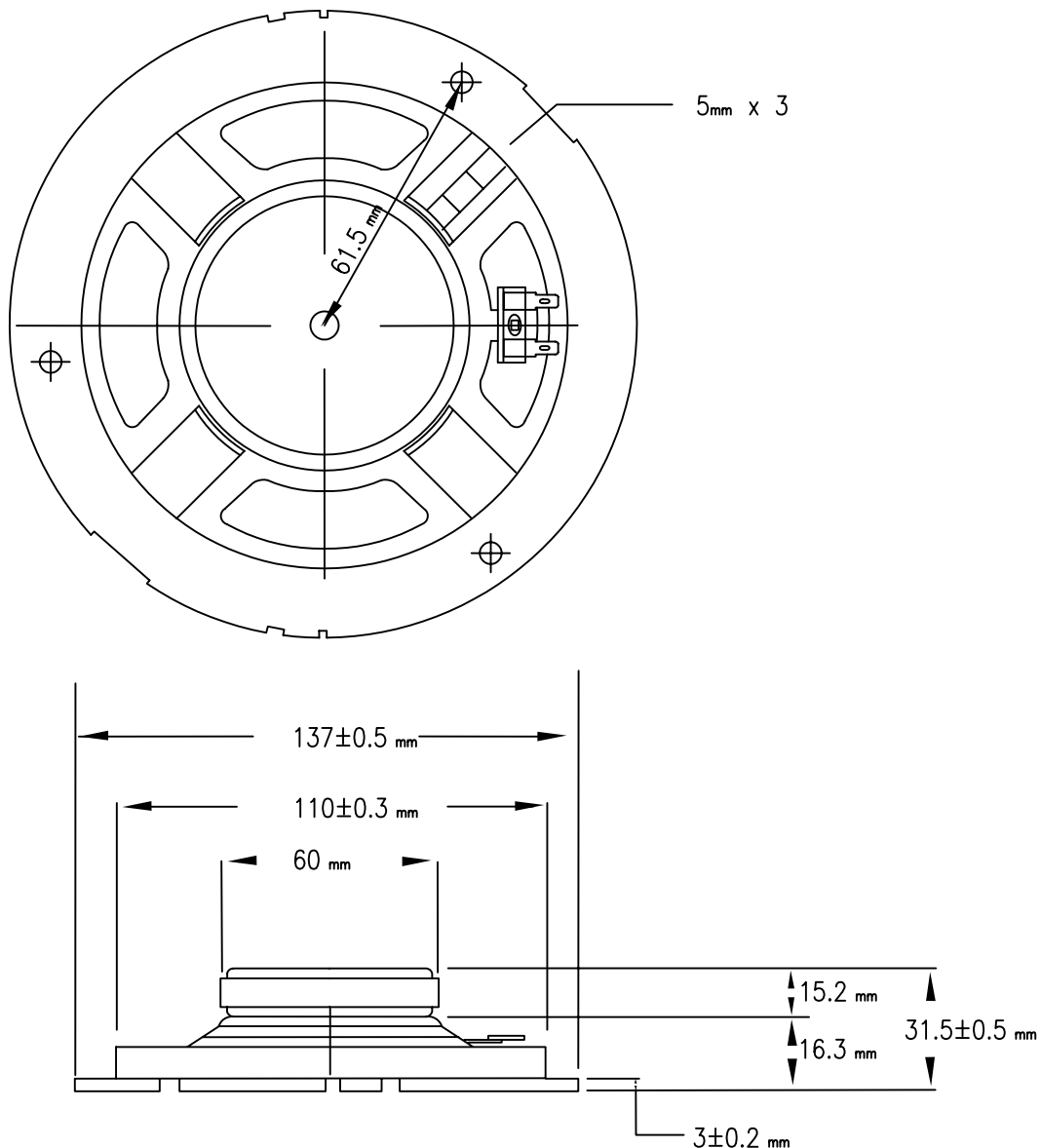

9615 SW Allen, Suite 103
 Beaverton, OR 97005
 Phone: (503) 643-4899
 800-275-4899
 Fax: (503) 372-1266
 Website: www.cui.com

TITLE:	
PART NO.	UNITS:
GF1207	mm
DRAWN BY:	Page No.
	2 of 2