



Chipsmall Limited consists of a professional team with an average of over 10 year of expertise in the distribution of electronic components. Based in Hongkong, we have already established firm and mutual-benefit business relationships with customers from,Europe,America and south Asia,supplying obsolete and hard-to-find components to meet their specific needs.

With the principle of “Quality Parts,Customers Priority,Honest Operation,and Considerate Service”,our business mainly focus on the distribution of electronic components. Line cards we deal with include Microchip,ALPS,ROHM,Xilinx,Pulse,ON,Everlight and Freescale. Main products comprise IC,Modules,Potentiometer,IC Socket,Relay,Connector.Our parts cover such applications as commercial,industrial, and automotives areas.

We are looking forward to setting up business relationship with you and hope to provide you with the best service and solution. Let us make a better world for our industry!



Contact us

Tel: +86-755-8981 8866 Fax: +86-755-8427 6832

Email & Skype: info@chipsmall.com Web: www.chipsmall.com

Address: A1208, Overseas Decoration Building, #122 Zhenhua RD., Futian, Shenzhen, China



NVIDIA GT610

PCIe 1X® ADD-IN BOARD

Datasheet

GFX-N3A1-71FMS1

CONTENTS

1.	Feature	3
2.	Functional Overview	4
2.1.	GPU Block diagram	4
2.2.	GPU	4
2.3.	Memory Interface	5
2.4.	Features and Technologies	5
2.5.	Display Support	5
2.6.	Digital Audio	5
2.7.	Video	6
3.	PIN Assignment and Description.....	7
3.1.	DVI-I Connector Pinout	7
3.2.	HDMI 1.4a Connector Pinout	8
3.3.	VGA Connector Pinout	9
3.4.	VGA Header Pinout.....	10
4.	Power Specifications	10
5.	Thermal Specifications	11
6.	Output configuration and Board Dimension.....	11
6.1.	Output Configuration	11
6.2.	Board Dimension	<u>12</u>
7.	Thermal Mechanism.....	13

1. Feature

Model Name	GFX-N3A1-71FMS1
Graphics Processing Unit	
GPU	GT520/GT610(GF119-300-A1)
Process Technology	40 nm
Graphics Engine Operating Frequency (max)	810 MHz
Form Factor	Low profile (144 X 68.9 mm)
Card Interface	PCI Express® 2.0 (X1)
CUDA Cores	48
Texture Fill Rate(billion/sec)	6.5
DirectX® capability	DirectX® 11
Shader Model	Shader Model 5.0
OpenGL	OpenGL™ 4.2
Video Decoder	H.264, VC-1, MPEG-2, MPEG-4 part 2 decode, MVC, 3D Blu Ray
Memory	
Memory Operating Frequency (max)	500 MHz / 1Gbps
Configuration, type	64-bit wide, 1 GB, DDR3
Display Interface	
Dual-Link DVI	Dual Link DVI-I
HDMI 1.4a	HDMI x1
VGA	Optional standard VGA via header and cable

2. Functional Overview

2.1. GPU Block diagram

Figure 1.1 shows a simplified block diagram of the GF119 GPU.

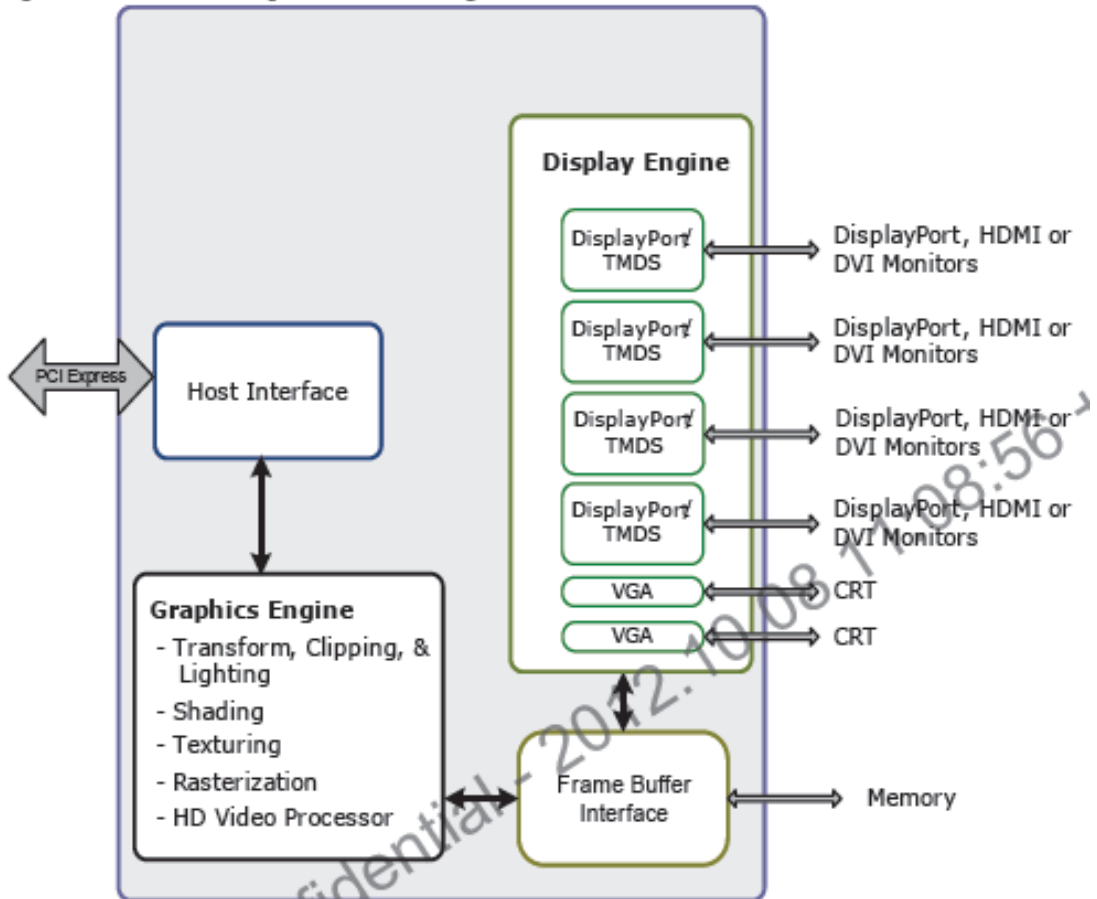

Figure 1.1 GF119 Simplified Block Diagram

2.2. GPU

Core clock:810 MHz

Voltage:1.040V (Voltage 1) and 1.110V (Voltage 2)

Packing size:23mmx23mm flip-chip plastic ball Grid array (FCPBGA)

2.3. Memory

Memory clock: 500MHz

Interface: 64-bit

Local framer buffer: 1024MB

8 piece 128M x 8 DDR3, FBGA-78 package

2.4. Features and Technologies

- ▶ Fully DirectX® 11 compliant and Shader Model 5.0
- ▶ OpenGL 4.2
- ▶ NVIDIA® Ageia PhysX™ technology
- ▶ NVIDIA® CUDA technology

2.5. Display Support

- ▶ Dual 400MHz integrated RAMDACs
- ▶ Maximum resolution/refresh:2048x1536x32bpp at 75Hz
- ▶ Internal dual-link TMDS
 - Maximum resolution over digital port:2560x1600x32bpp at 60HZ
- ▶ HDMI 1.4a
 - PC mode:1920x1200 at 60Hz
 - TV mode:1080p(1920x1080 at 60Hz)
- ▶ High definition digital content protection(HDCP)support

2.6. Digital Audio

- ▶ Supports for HD Audio over PCI Express
- ▶ Support for secure premium audio (e.g. 7.1 Audio)
- ▶ Data rates of 44.1KHz, 48KHz, 88.2KHz, 96KHz, 176KHz and 192KHz
- ▶ Word sizes of 16-bit, 20bit, and 24-bit

2.7. Video

The following video formats are supported:

- ▶ MPEG-2
- ▶ MPEG-4 Part 2 Advanced Simple Profile
- ▶ H.264 SVC codec support
- ▶ Support for 3D Blu Ray
- ▶ VC1
- ▶ DivX version 3.11 and later
- ▶ MVC

A full range of video resolutions are supported including 1080p, 1080i, 720p, 480p and 480i

3. PIN Assignment and Description

3.1 DVI-I Connector Pinout

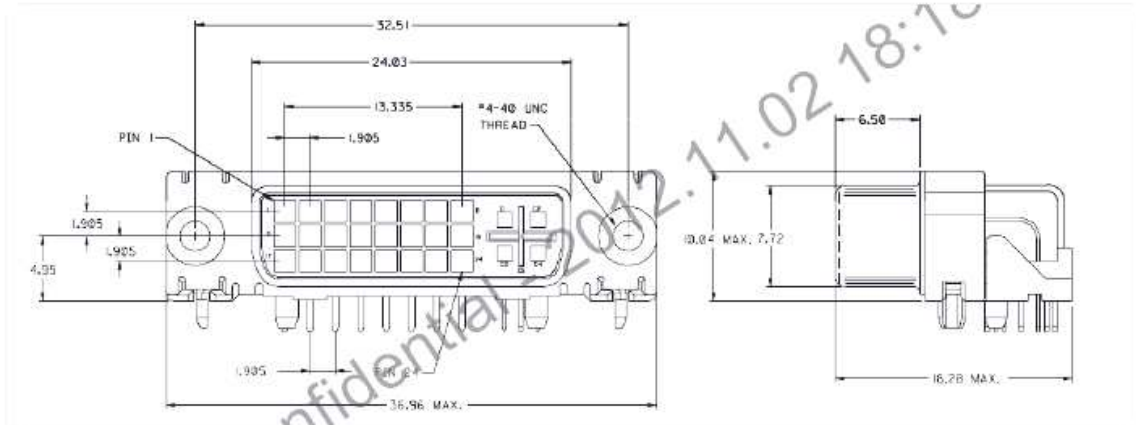

Pin	Signal	Pin	Signal
1	TMDS data 2-	13	TMDS data 3+
2	TMDS data 2+	14	+5VDC power
3	TMDS data 2/4 shield	15	Ground (Return for +5)
4	TMDS data 4-	16	Hot plug detected
5	TMDS data 4+	17	TMDS data 0-
6	DDC clock	18	TMDS data 0+
7	DDC data	19	TMDS data 0/5 shield
8	Analog vertical sync	20	TMDS data 5-
9	TMDS data 1-	21	TMDS data 5+
10	TMDS data 1+	22	TMDS clock shield
11	TMDS data 1/3 shield	23	TMDS clock+
12	TMDS data 3-	24	TMDS clock-
C1	Analog red	C4	Analog horizontal sync
C2	Analog green	C5	Analog ground (RGM return)
C3	Analog blue		

3.2 HDMI 1.4a Connector Pinout

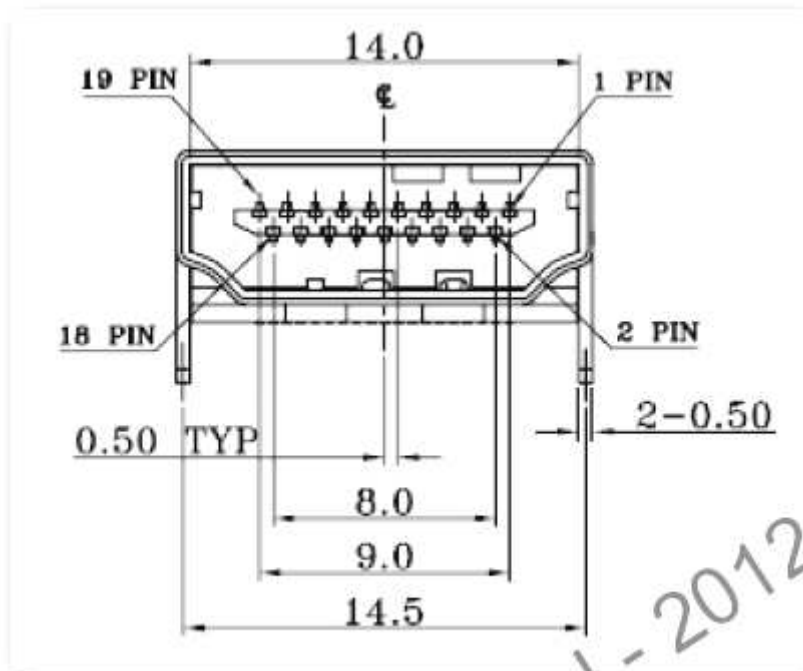

Pin	Signal	Pin	Signal
1	TMDS Data 2+	11	TMDS Clock Shield
2	TMDS Data 2 Shield	12	TMDS Clock-
3	TMDS Data 2-	13	No Connect
4	TMDS Data 1+	14	No Connect
5	TMDS Data 1 Shield	15	DDC Clock
6	TMDS Data 1-	16	DDC Data
7	TMDS Data 0+	17	Ground
8	TMDS Data 0 Shield	18	+5V Power
9	TMDS Data 0-	19	Hot Plug Detect
10	TMDS Clock+		

3.3 VGA Connector Pinout

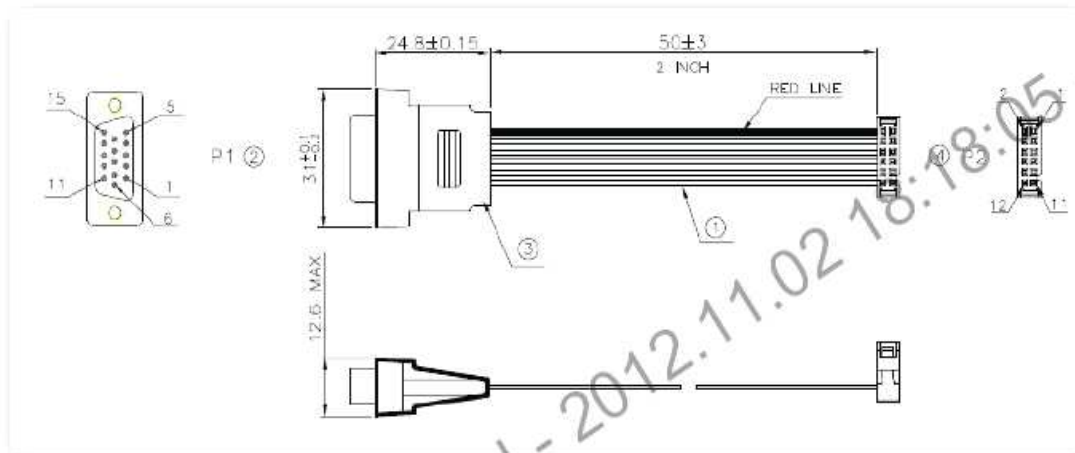

Pin	Signal	Description
1	Red	Red
2	Green	Green
3	Blue	Blue
4	Reserved	Macintosh sense , RW
5	Ground	DDC return
6		Red ground
7		Green ground
8		Blue ground
9	+5V	DDC power
10	SGND	Sync ground
11	ID0	Monitor ID bit 0 (Opt)
12	SDA	Serial data (DDC2B)
13	HSYNC	Horizontal sync
14	VSYNC	Vertical sync
15	SCL	Serial clock (DDC2B)

3.4 VGA Header Pinout

Pin	Signal	Description
1	SCL	Serial clock (DDC2B)
2	SDA	Serial data (DDC2B)
3	+5V	DDC power
4	VSYNC	Vertical sync
5	HSYNC	Horizontal sync
6	GND	Ground
7	Red	Red
8	GND	Ground
9	Green	Green
10	GND	Ground
11	Blue	Blue
12	GND	Ground

4. Power Specifications

Parameter	Value	Unit
Input Board Power (Estimated)		
PCI Express edge connector (12V) (estimated input power)	2.4	A
	28.5	W
PCI Express edge connector (3V3) (estimated input power)	0.15	A
	0.5	W
Total estimated input graphics power (estimated TGP)	29	W
Component Power (Estimated)		
GPU (TDP, estimated)	18.7	W
Memory power (estimated; eight components)	3.6	W
Power supplies	4.5	W
PCB and others losses	2.2	W

5. Thermal Specifications

Parameter	Value	Unit
Fan inlet temperature (max.)	55	°C
GPU slowdown temperature (max.Tj)	102	°C
GPU shutdown temperature (max.Tj)	107	°C
GPU junction temperature (estimated)	72	°C
Memory case temperature (max.)	52.9	°C
Power FET case temperature (max.)	78.2	°C

6. Output configuration and Board Dimension

6.1. Output Configuration



6.2 Board Dimension

(Unit : mm)

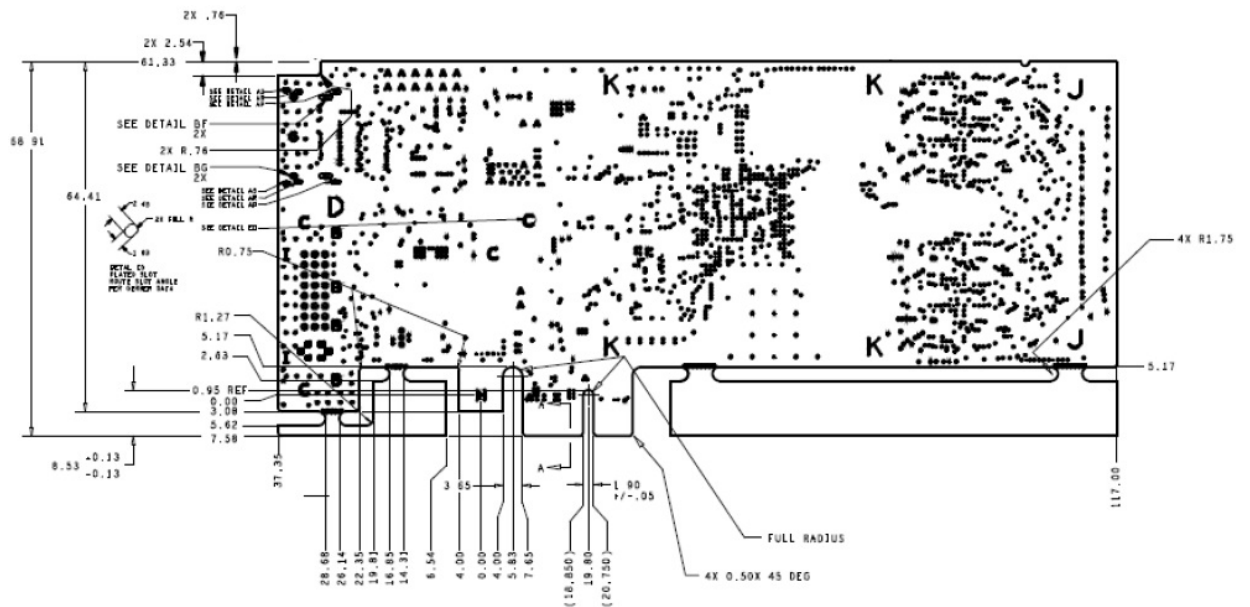

Tolerances : +/- 0.13 mm

7. Thermal Mechanism

(Unit : mm)

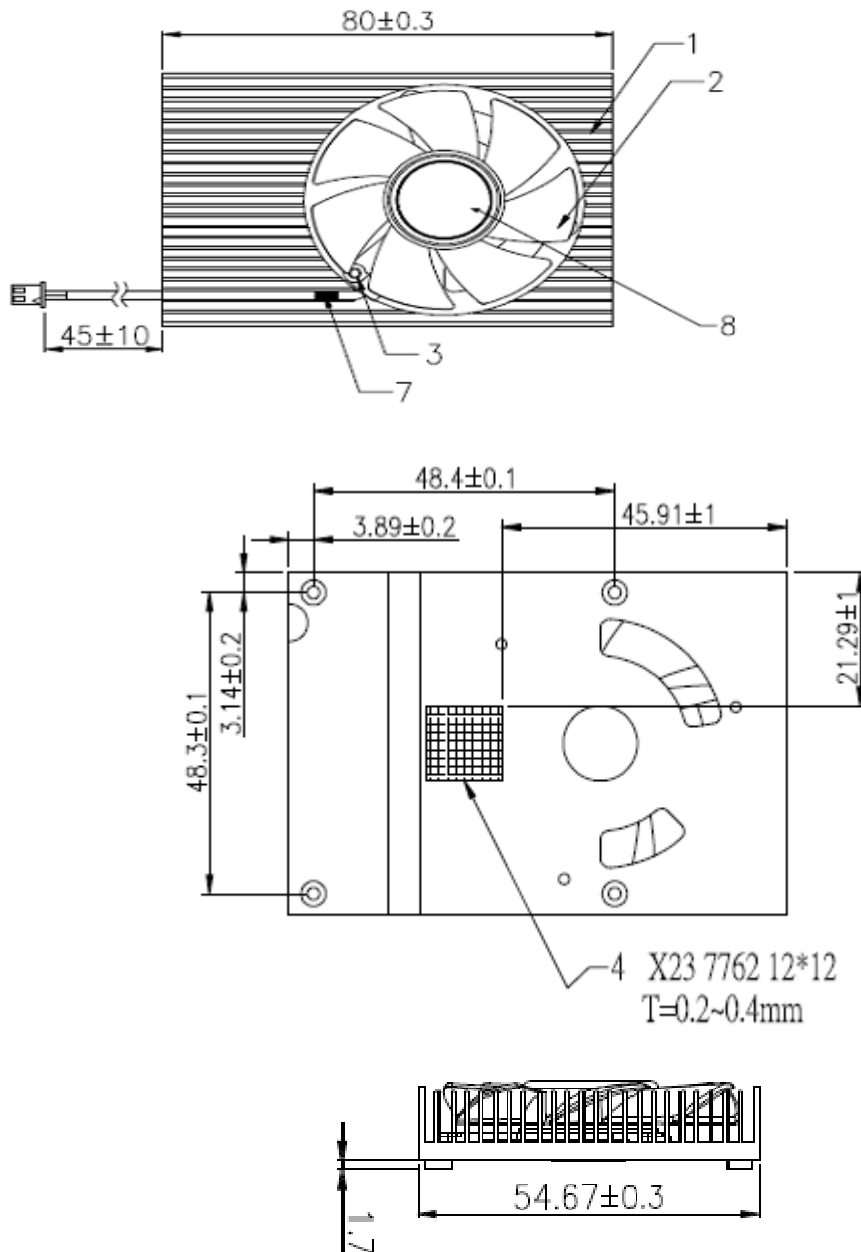

Change log or update history

Rev.	Data	History
0.1	2012/9/26	1 st Draft
0.2	2012/10/19	2 nd Draft
0.3	2012/11/05	3 rd Draft