



Chipsmall Limited consists of a professional team with an average of over 10 year of expertise in the distribution of electronic components. Based in Hongkong, we have already established firm and mutual-benefit business relationships with customers from,Europe,America and south Asia,supplying obsolete and hard-to-find components to meet their specific needs.

With the principle of “Quality Parts,Customers Priority,Honest Operation,and Considerate Service”,our business mainly focus on the distribution of electronic components. Line cards we deal with include Microchip,ALPS,ROHM,Xilinx,Pulse,ON,Everlight and Freescale. Main products comprise IC,Modules,Potentiometer,IC Socket,Relay,Connector.Our parts cover such applications as commercial,industrial, and automotives areas.

We are looking forward to setting up business relationship with you and hope to provide you with the best service and solution. Let us make a better world for our industry!



Contact us

Tel: +86-755-8981 8866 Fax: +86-755-8427 6832

Email & Skype: info@chipsmall.com Web: www.chipsmall.com

Address: A1208, Overseas Decoration Building, #122 Zhenhua RD., Futian, Shenzhen, China



SPECIFICATION

Part No. : **GGBLA.01.A**

Product Name : Unifier GPS/GLONASS/BEIDOU Ceramic SMD
Antenna

Feature : 3.2*1.6*0.5mm
Low profile Ceramic Loop antenna
Omnidirectional
RoHS compliant

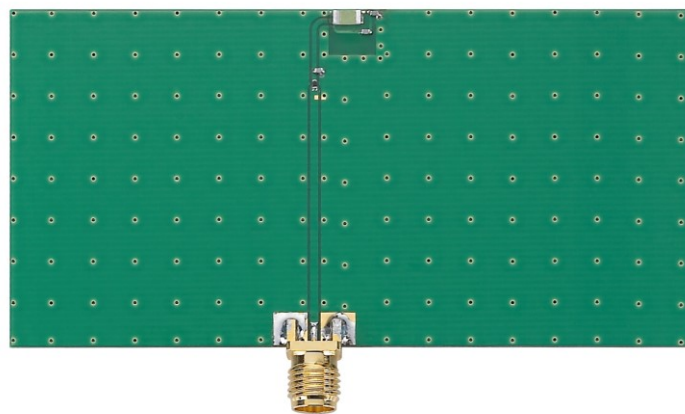

1. Introduction

Taoglas have developed a unique ceramic miniature loop antenna series for GPS-GLONASS-BEIDOU applications. At 3.2*1.6*0.5mm, the Unifier GGBLA.01.A Loop antenna is a miniature edge mounted SMD antenna, designed for small space requirements. Typical applications are small sized automotive navigation or position tracking systems and hand-held devices when GNSS function is needed.

The radiation pattern is more omnidirectional than traditional patch antennas. The Unifier antenna series wide bandwidth allows high efficiency, stable reception on all three GPS, GLONASS and BeiDou bands from 1555MHz to 1602MHz

Efficiencies of 64% to 85% are achievable. Peak gain of 3.3dBi places this antenna gain performance within the range of a much larger 15mm to 18mm patch antennas.

Based on the loop effect this antenna works best when placed on the centre of the edge of the board, but can still work better than traditional linear polarized chip antennas even when placed at corners as substitute.

The Unifier GGBLA.01.A is delivered on tape and reel and now allows M2M customers to use an omnidirectional antenna in devices where orientation of the product is unknown. Like all small antennas, care must be taken to ensure the device ground-plane layout and antenna matching has been done correctly, Taoglas offers professional gerber review, transmission line design, general integration support and final matching service of the GGBLA.01.A on your device board at our regional labs worldwide. Contact your regional Taoglas sales office for immediate support.

2. Specification

Measured on a 80*40mm ground plane

ELECTRICAL GPS BAND	
Working Frequency*	1575.42MHz
VSWR	2.0 : 1 max
Polarization	Linear
Gain	Peak gain: 3.2 Typ.
Impedance	50 Ω

ELECTRICAL GLONASS BAND	
Working Frequency*	1598~1608MHz
VSWR	2.0 : 1 max
Polarization	Linear
Gain	Peak gain: 2.6 Typ.
Impedance	50 Ω

ELECTRICAL COMPASS-BEIDOU BAND	
Working Frequency*	1561 MHz
VSWR	2.0 : 1 max
Polarization	Linear
Gain	Peak gain: 2.8 Typ.
Impedance	50 Ω

MECHANICAL	
Dimensions	3.2 x 1.6 x 0.5 mm
Material	Ceramic

ENVIRONMENTAL	
Operation Temperature	-40°C to 85°C
Storage Temperature	-40°C to 85°C
Humidity	20% to 70%

3. Antenna Characteristics

3.1. Return Loss

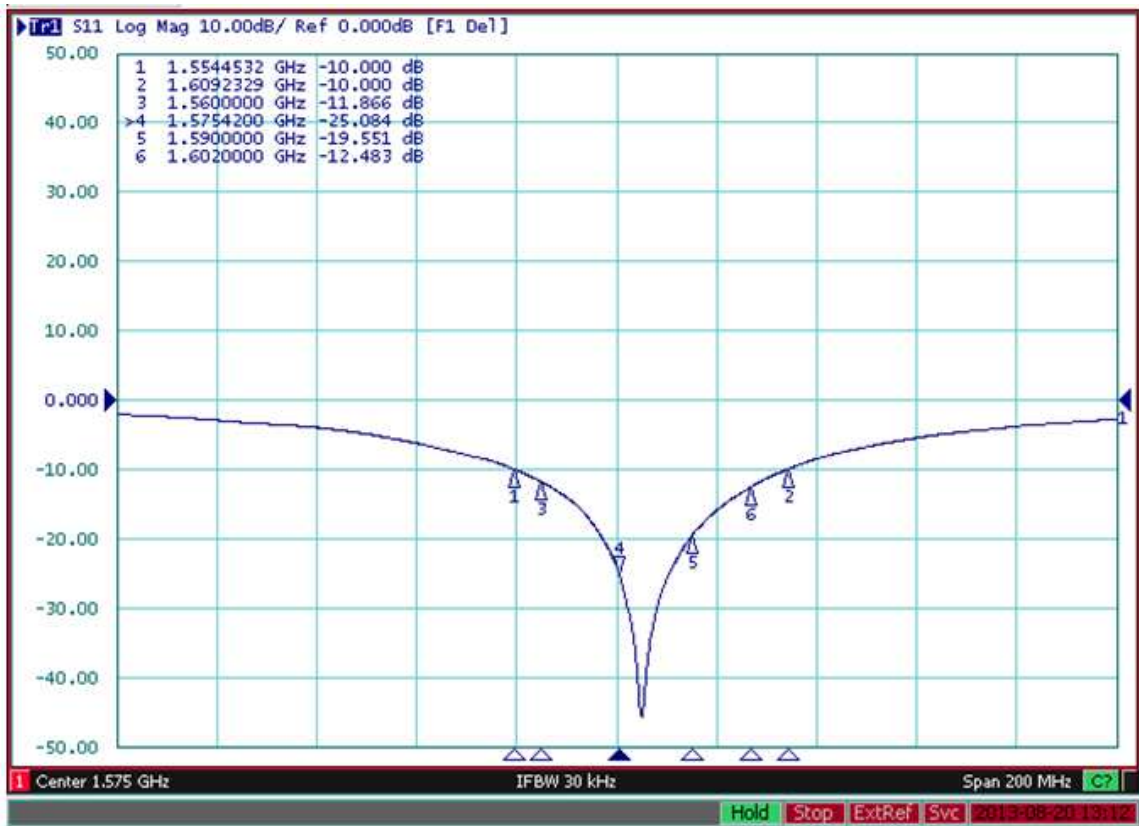

3.2. VSWR

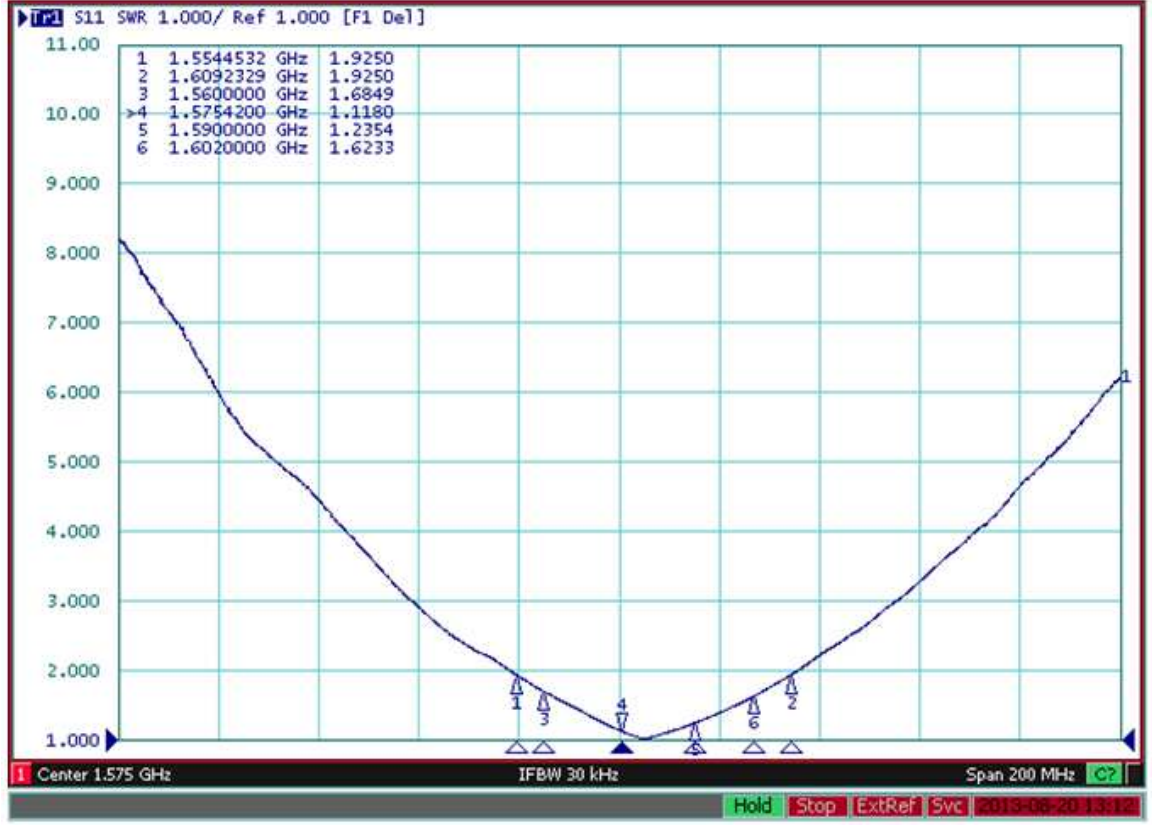

3.3. Efficiency

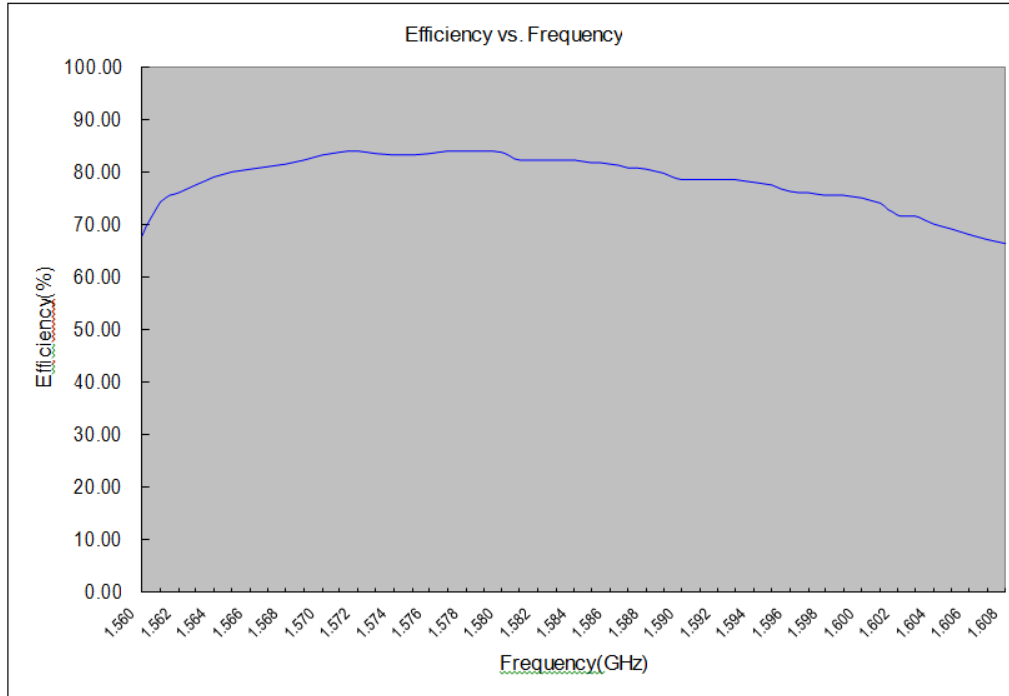

3.4. Efficiency and Gain table

Frequency(GHz)	1.560	1.561	1.562	1.563	1.564	1.565	1.566	1.567	1.568	1.569	1.570	1.571	1.572	1.573	1.574	1.575	1.576	1.577	1.578	1.579	1.580
Efficiency(dB)	-1.68	-1.29	-1.18	-1.10	-1.02	-0.97	-0.94	-0.91	-0.88	-0.85	-0.79	-0.77	-0.76	-0.78	-0.79	-0.79	-0.78	-0.76	-0.76	-0.75	-0.77
Efficiency(%)	67.93	74.32	76.22	77.64	79.09	80.00	80.55	81.11	81.67	82.24	83.38	83.77	83.96	83.58	83.38	83.43	83.58	83.96	83.96	84.16	83.77
Gain(dBi)	2.82	2.90	2.99	3.05	3.10	3.14	3.17	3.20	3.21	3.24	3.29	3.29	3.30	3.28	3.29	3.29	3.29	3.29	3.29	3.28	3.26

Frequency(GHz)	1.581	1.582	1.583	1.584	1.585	1.586	1.587	1.588	1.589	1.590	1.591	1.592	1.593	1.594	1.595	1.596	1.597	1.598	1.599	1.600	1.601
Efficiency(dB)	-0.84	-0.84	-0.85	-0.85	-0.87	-0.89	-0.93	-0.94	-0.98	-1.05	-1.04	-1.04	-1.04	-1.07	-1.10	-1.17	-1.19	-1.21	-1.21	-1.24	-1.30
Efficiency(%)	82.36	82.43	82.24	82.24	81.86	81.49	80.74	80.55	79.82	78.54	78.72	78.72	78.72	78.18	77.64	76.43	76.05	75.70	75.70	75.18	74.14
Gain(dBi)	3.16	3.17	3.14	3.12	3.11	3.08	3.05	3.03	2.99	2.93	2.93	2.92	2.90	2.88	2.84	2.82	2.77	2.75	2.74	2.71	2.66

Frequency(GHz)	1.602	1.603	1.604	1.605	1.606	1.607	1.608
Efficiency(dB)	-1.65	-1.45	-1.54	-1.60	-1.67	-1.73	-1.78
Efficiency(%)	71.98	71.63	70.16	69.20	68.09	67.16	66.39
Gain(dBi)	2.58	2.54	2.46	2.41	2.36	2.31	2.28

4. 3D Antenna Radiation Pattern

4.1 BeiDou 1560MHz (80*40mm Ground Plane)

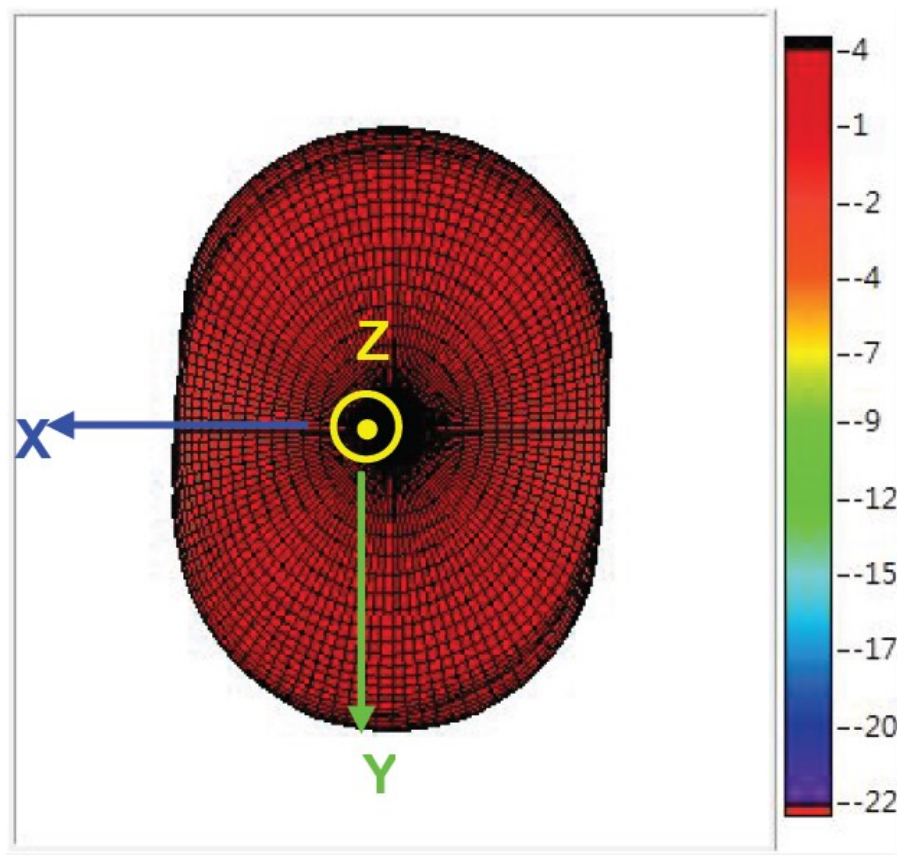
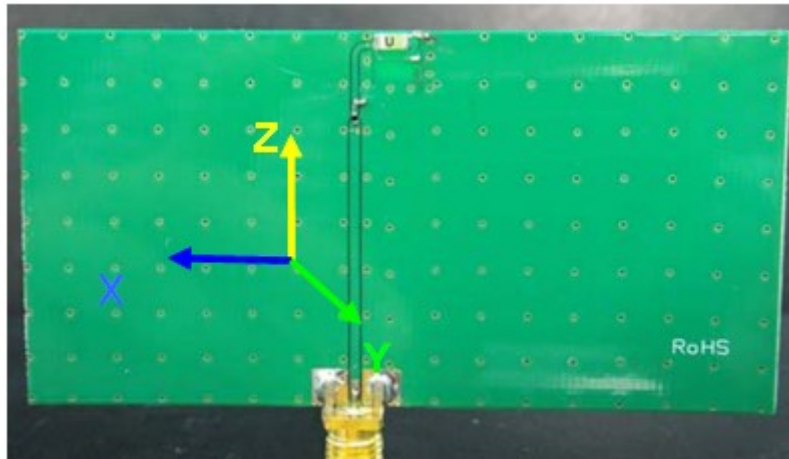

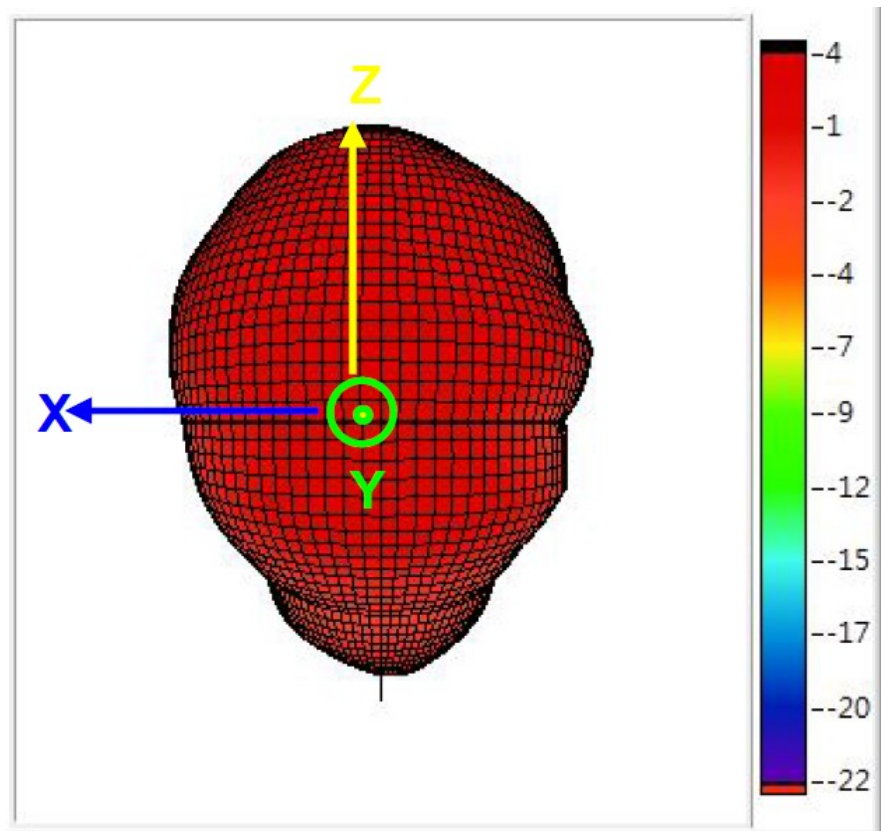
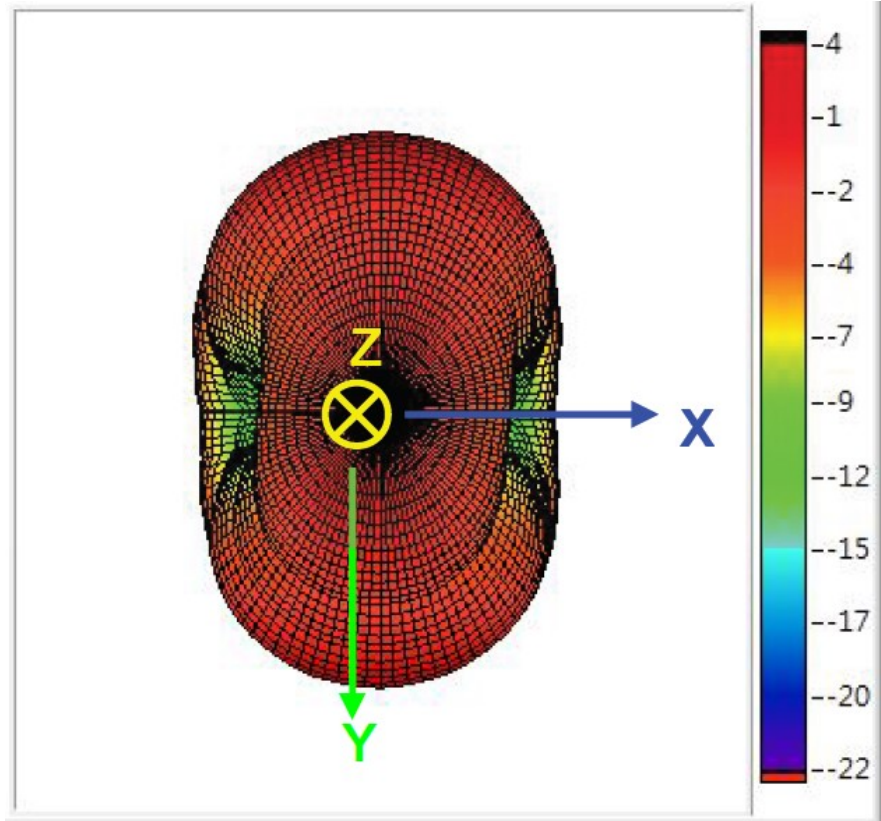

4.2 GPS 1575MHz (80*40mm Ground Plane)

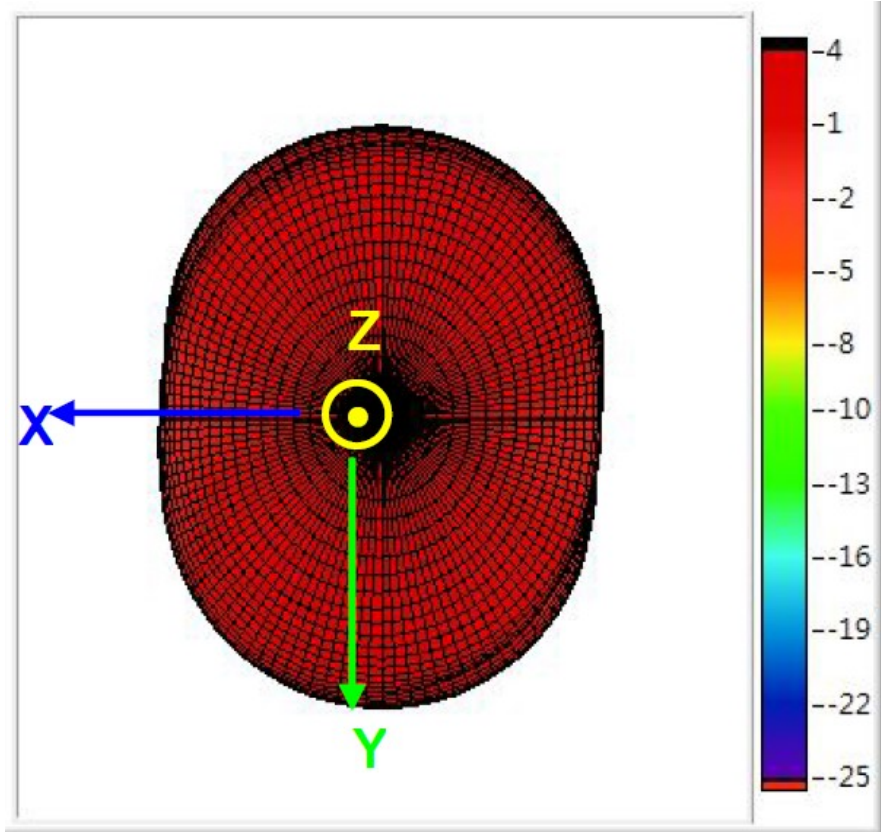
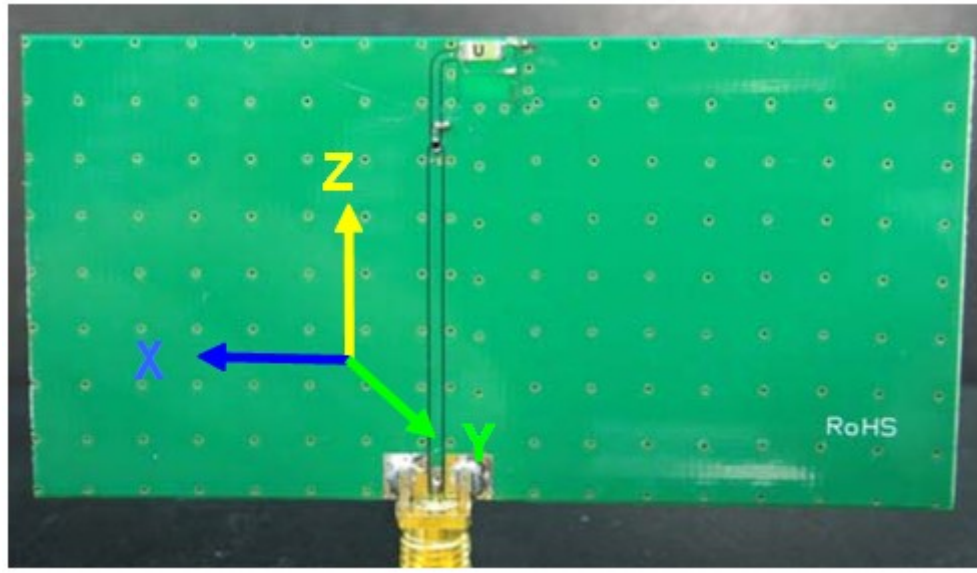

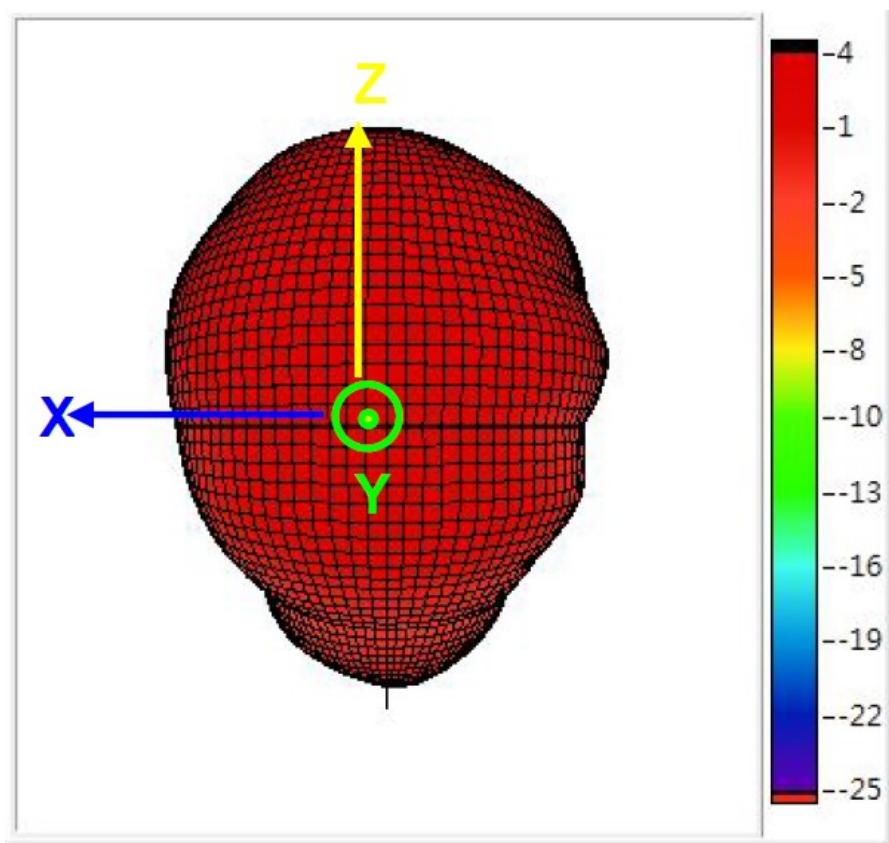
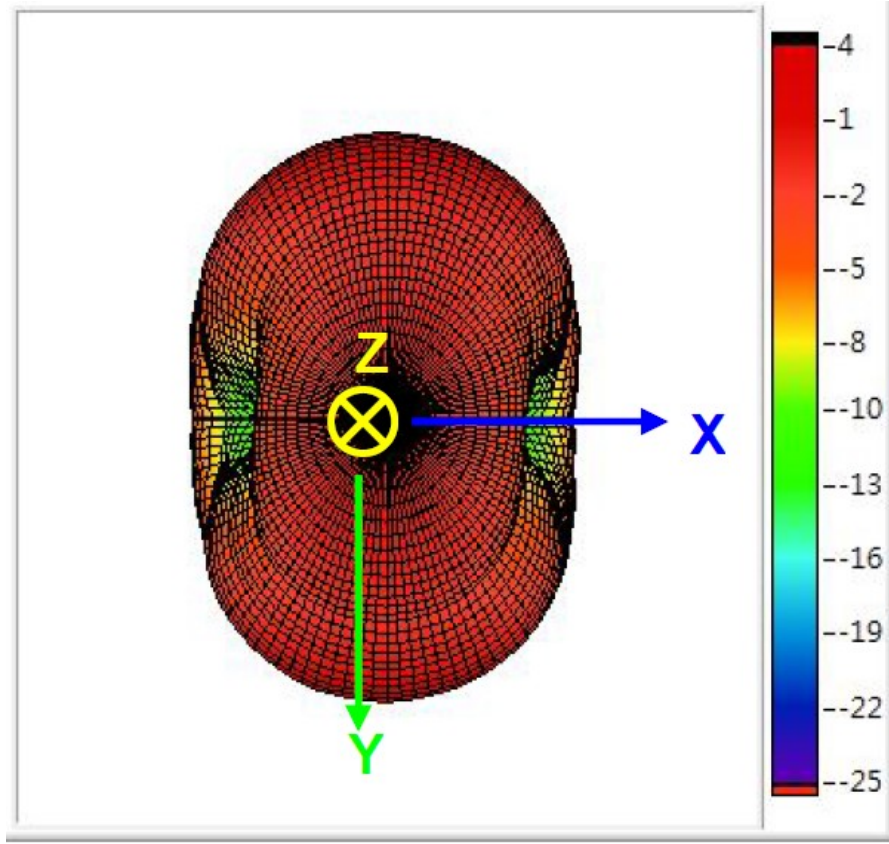

4.3 GLONASS 1602MHz (80*40mm Ground Plane)

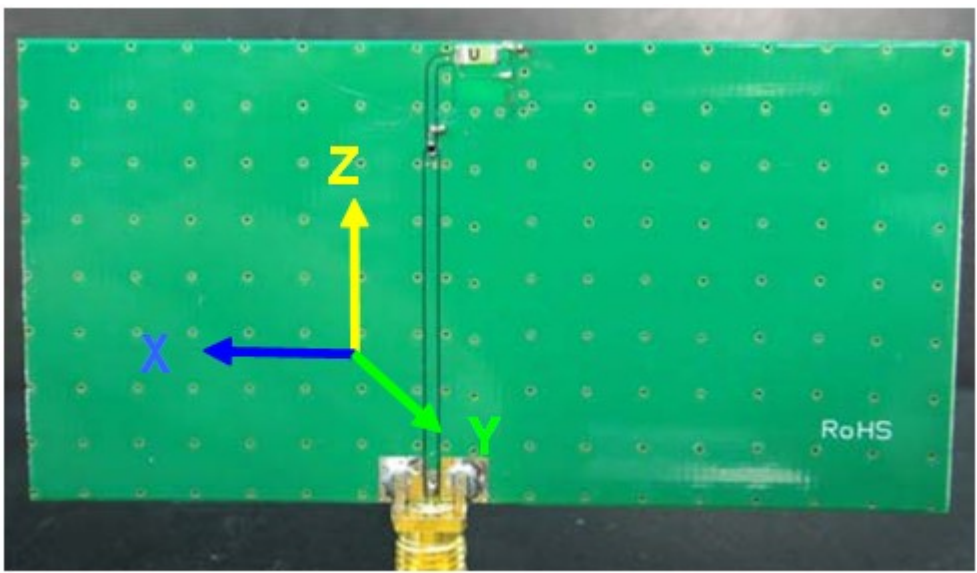

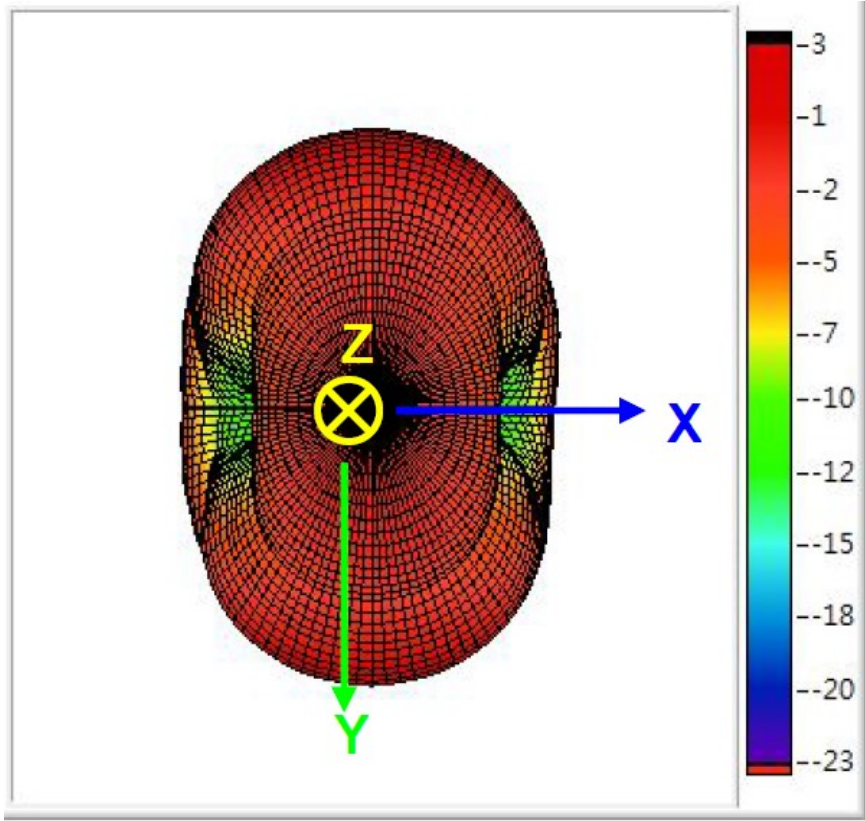
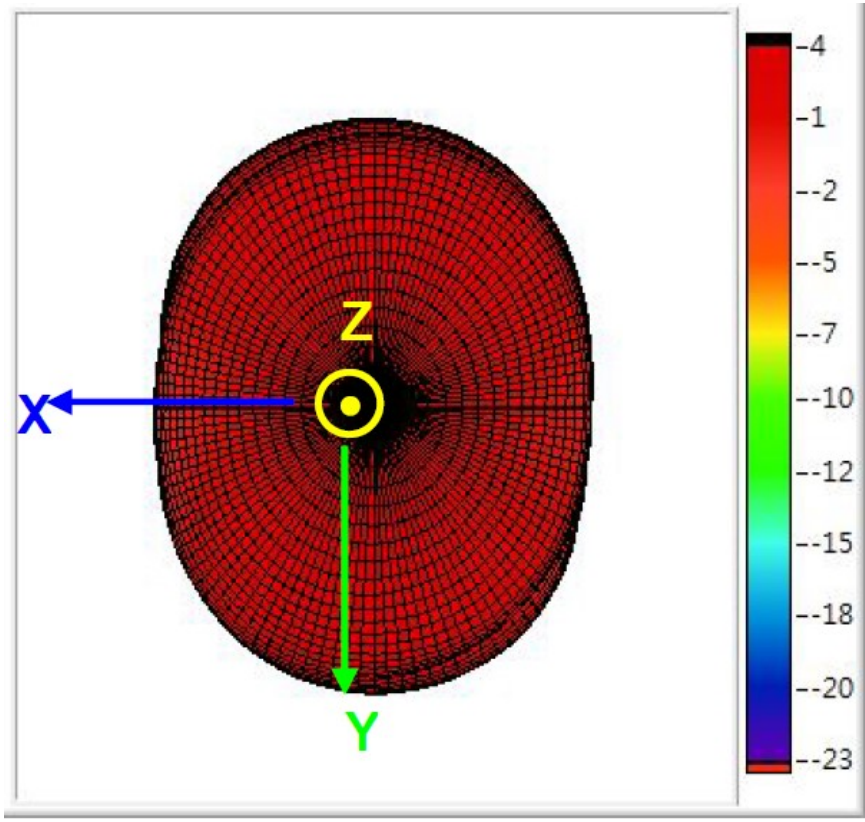

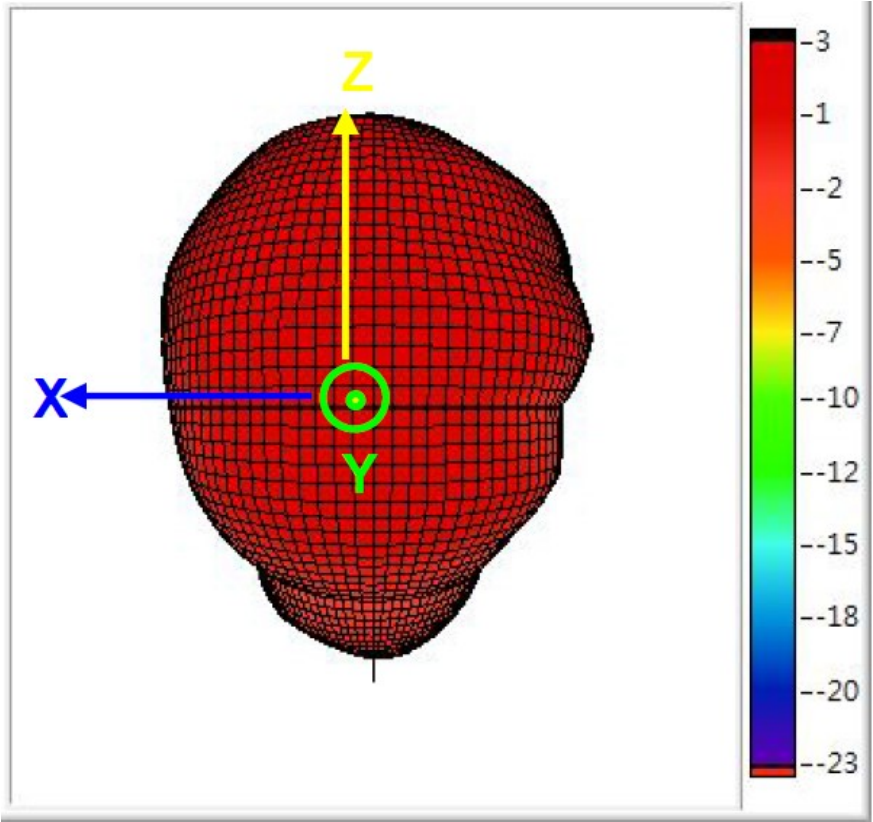

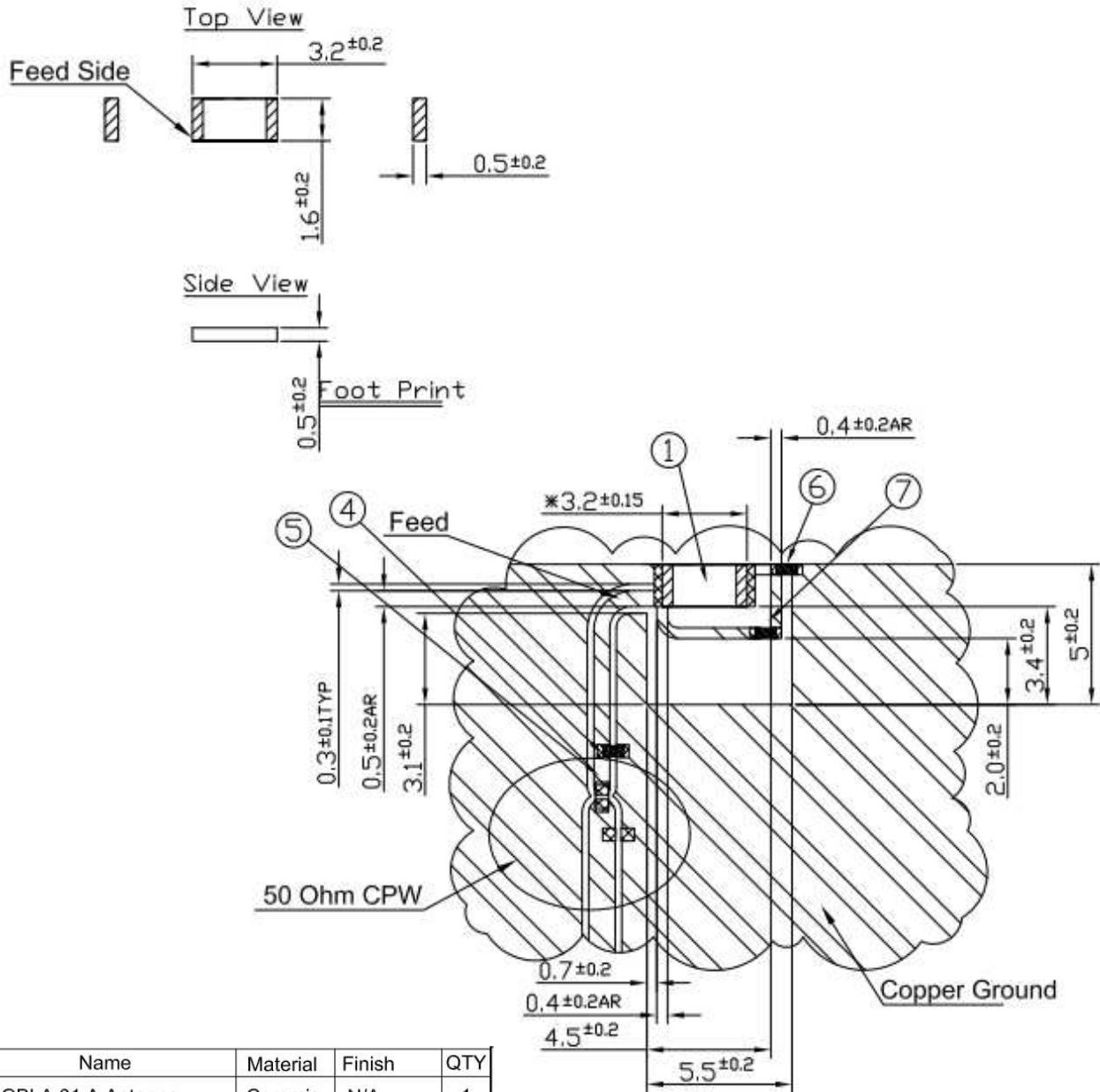

5. Drawing (Unit: mm)

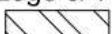

	Name	Material	Finish	QTY
1	GGBLA.01.A Antenna	Ceramic	N/A	1
2	GGBLAD.01.A EVB Board	FR4 0.8t	Green	1
3	SMA (F) ST	Brass	Gold	1
4	3pF Capacitor (0402)	Ceramic	N/A	1
5	0Ω Resistor (0402)	Ceramic	N/A	1
6	4pF Capacitor (0402)	Ceramic	N/A	1
7	1pF Capacitor (0402)	Ceramic	N/A	1

NOTES:

1. Silver Area 
2. Logo & Text Ink Printing : Black
3.  Copper
4.  Matching Component
5.  Solder
6. " * " Critical Dimensions

6. Drawing EVB (Unit: mm)

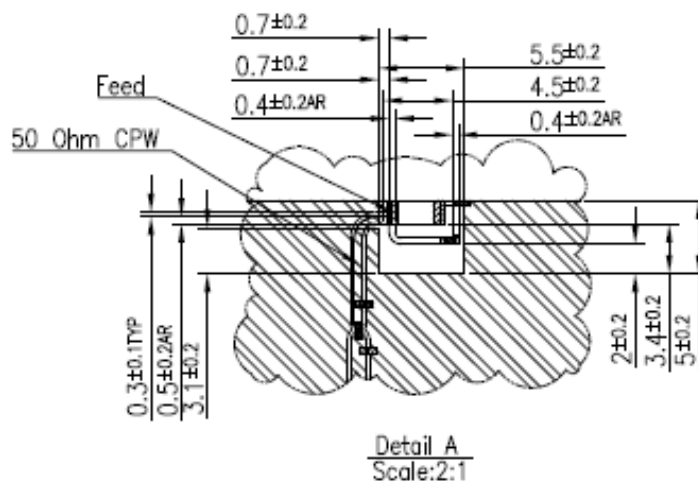
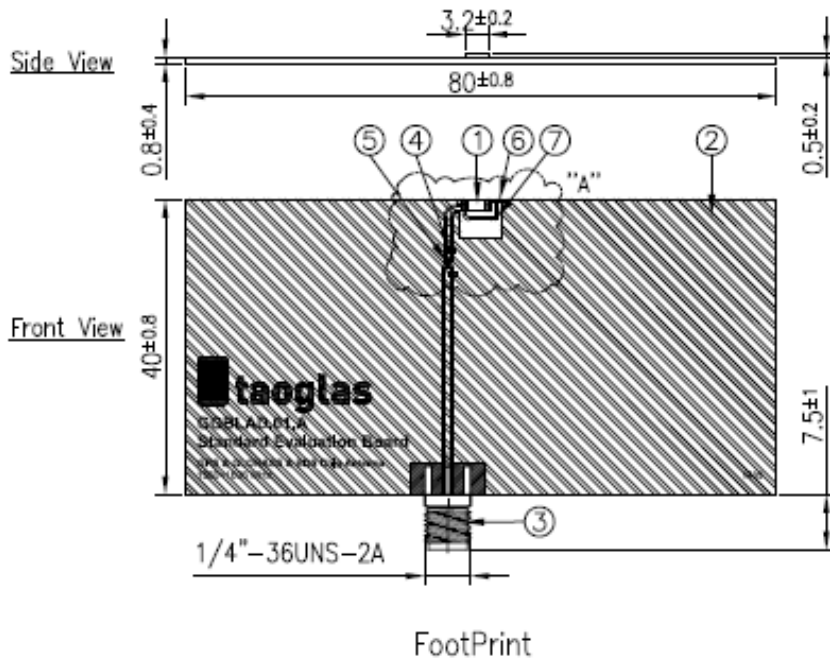

NOTES:

1. Solder Area 
2. Logo & Text Ink Printing : White
3.  Copper
4.  Matching Component

	Name	P/N	Material	Finish	QTY
1	GGBLA.01.A Antenna	001513020012A	Ceramic	N/A	1
2	GGBLA.01.A EVB Board	100213000012A	Composite 0.8mm	Black	1
3	SMA(F) ST	200413000012A	Brass	Au Plated	1
4	Capacitor 0.8pF (0402)	001516L010012A	Ceramic	N/A	1
5	Capacitor 2.7pF (0402)	001513F010012A	Ceramic	N/A	1
6	Capacitor 22pF (0402)	001516B040012A	Ceramic	N/A	1
7	Capacitor 0.5pF (0402)	001516L020012A	Ceramic	N/A	1

7. Layout Guide

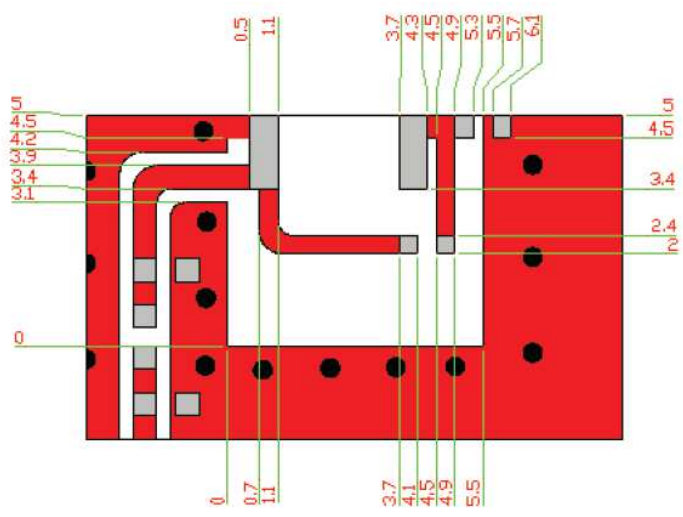

Top View

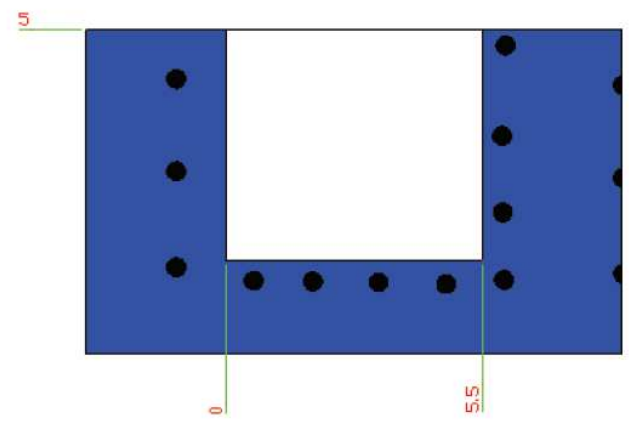

Bottom View

Unit: mm

8. Frequency tuning

8.1 Antenna tuning

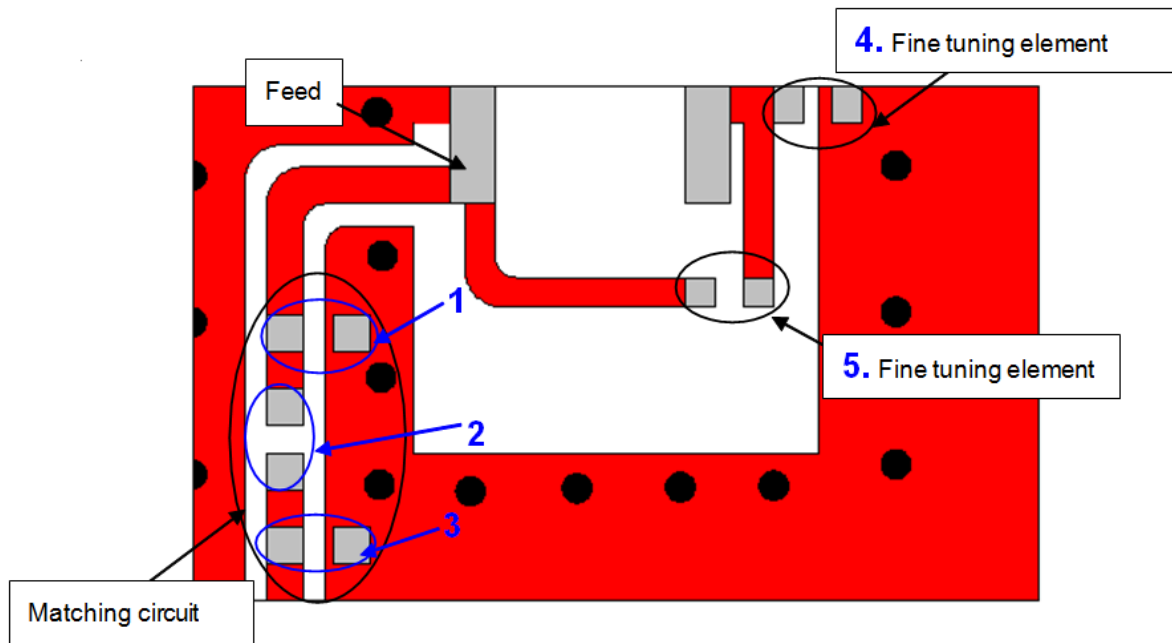

8.2 Matching Circuit (center frequency 1575.42Mhz @ 80*40mm Ground)

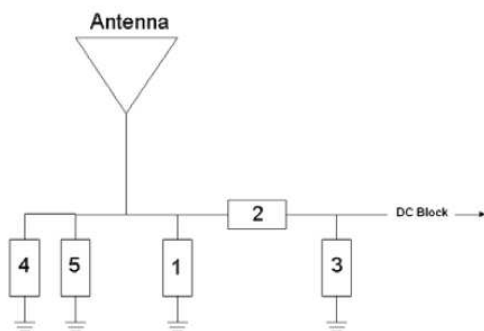

System Matching Circuit Component			
Location	Description	Vendor	Tolerance
1	3 pF	DARFON(0402)	±0.1pF
2	0Ω	(0402)	-
3	N/A	-	-
Fine tuning element 4	4 pF	DARFON(0402)	±0.1pF
Fine tuning element 5	1 pF	DARFON(0402)	±0.1pF

8.3 Fine tuning element vs. Center Frequency

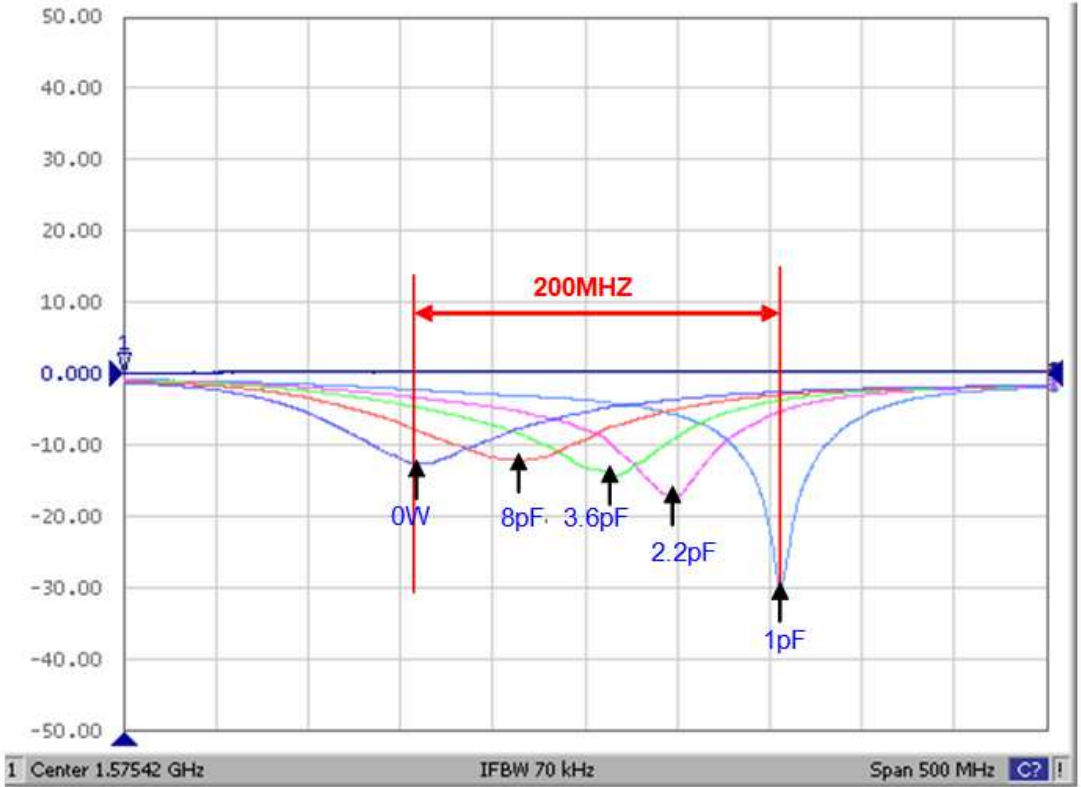

9. Recommended Reflow Profile

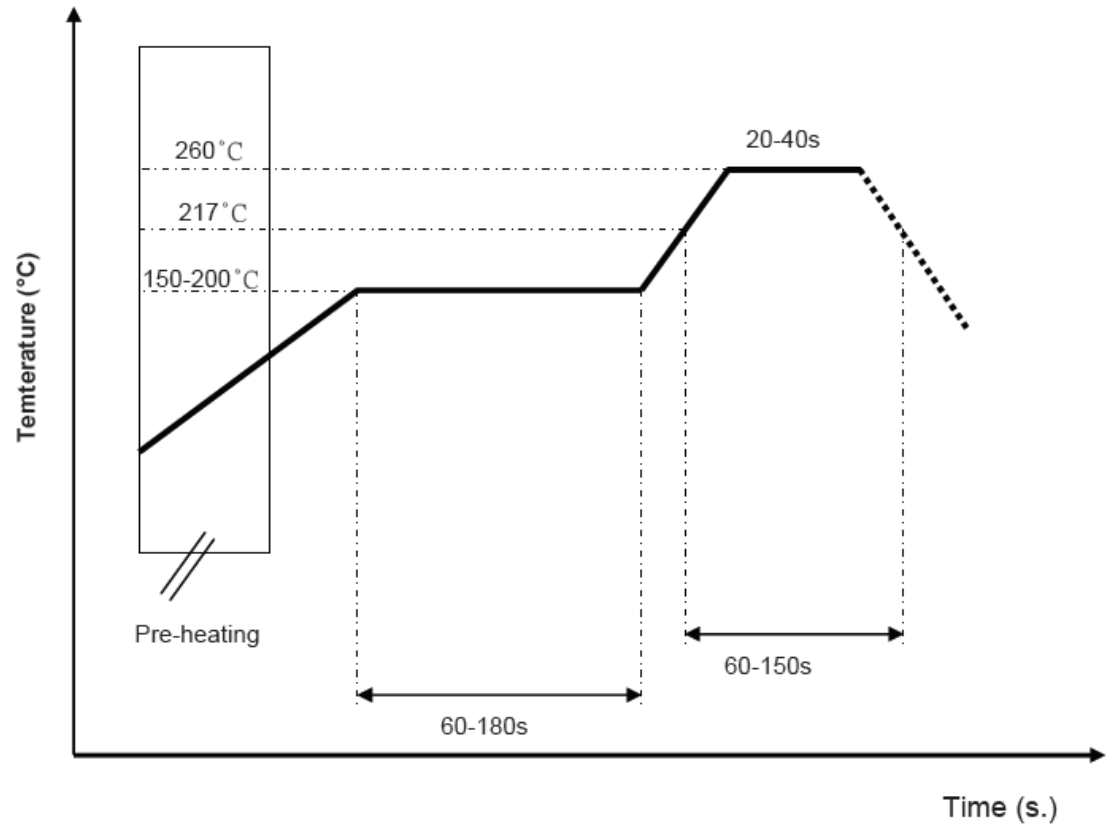

10. Packing

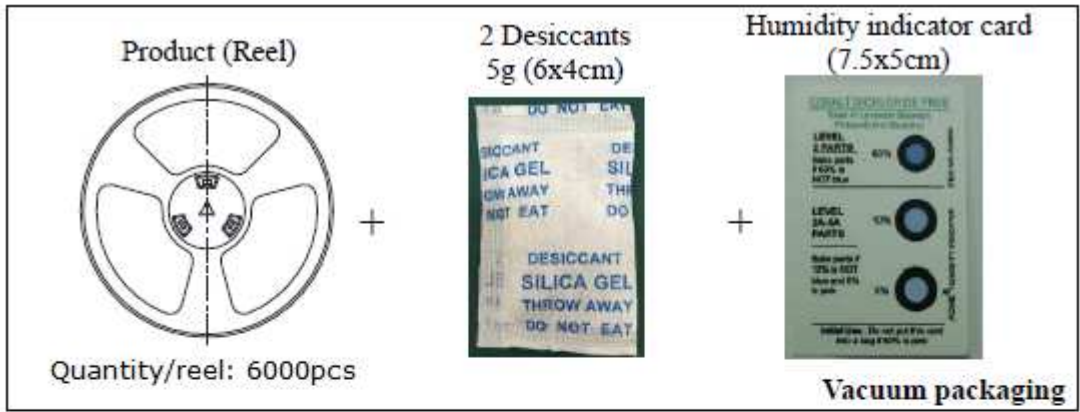

(1) Quantity / Reel: 6000pcs/Reel

(2) Plastic tape:

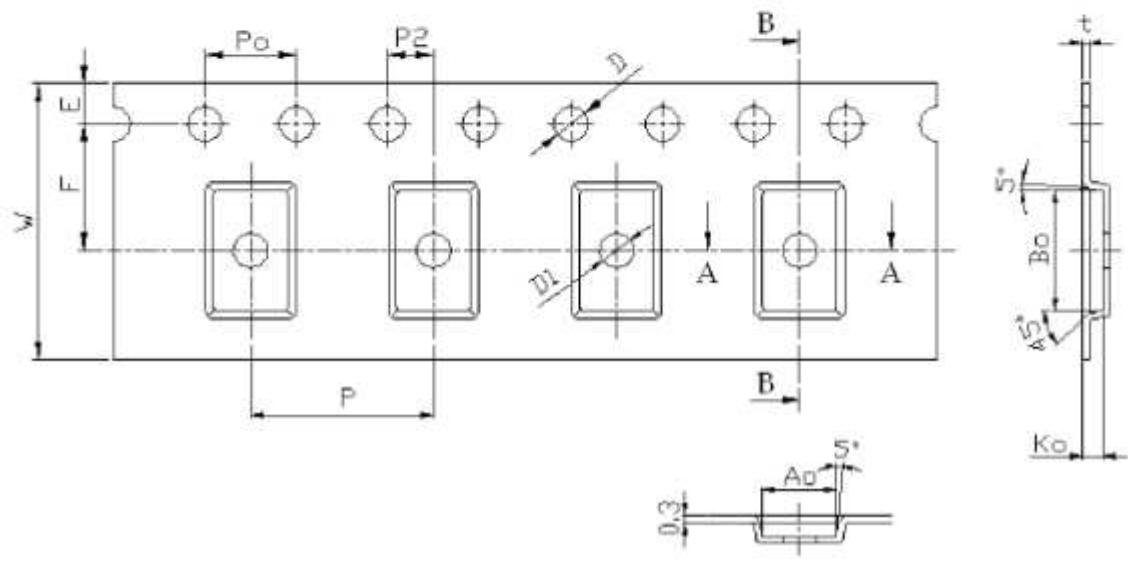

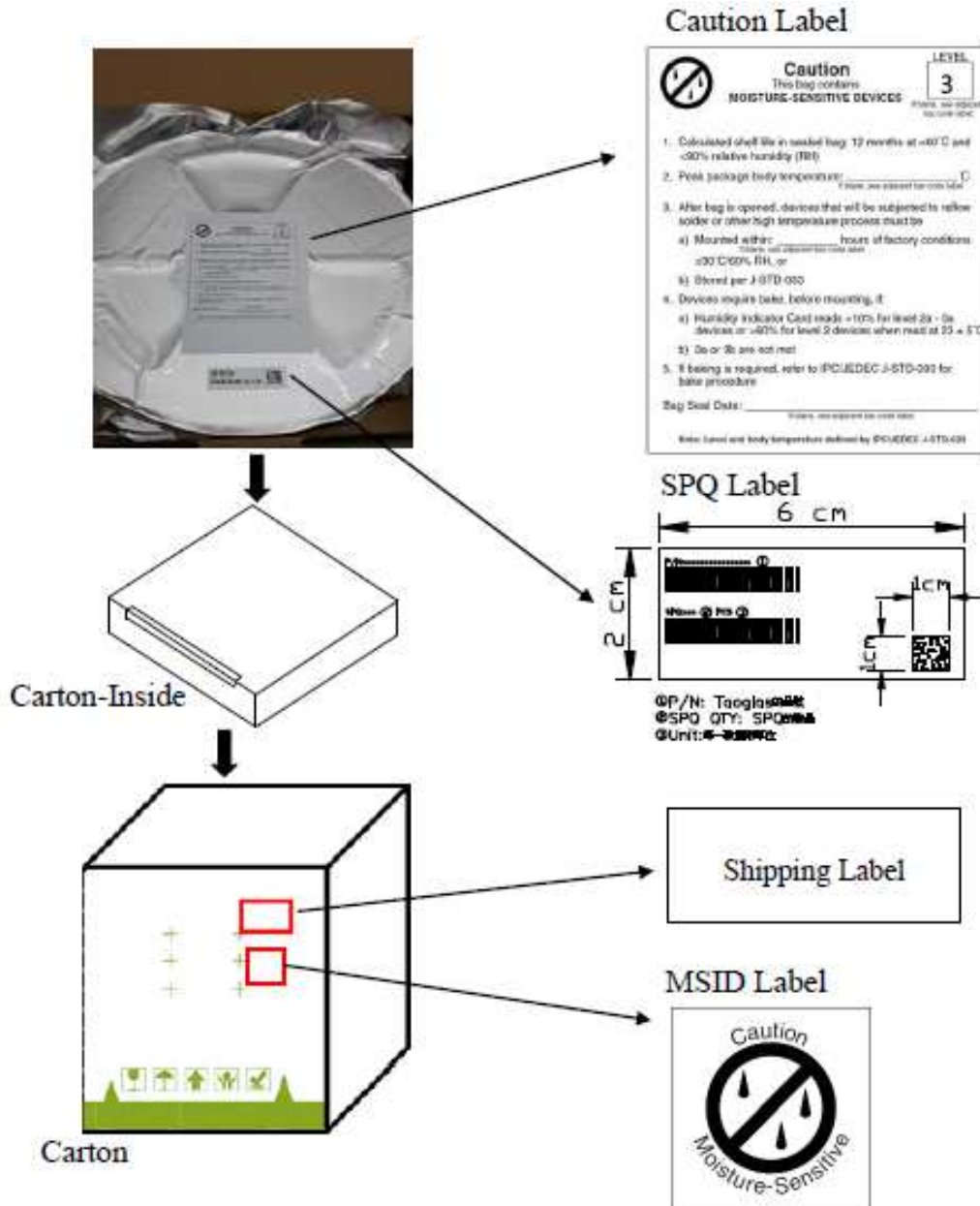



Taoglas makes no warranties based on the accuracy or completeness of the contents of this document and reserves the right to make changes to specifications and product descriptions at any time without notice.

Taoglas reserves the rights to this document and the information contained herein. Reproduction, use or disclosure to third parties without express permission is strictly prohibited.

Copyright © Taoglas Ltd.