



Chipsmall Limited consists of a professional team with an average of over 10 year of expertise in the distribution of electronic components. Based in Hongkong, we have already established firm and mutual-benefit business relationships with customers from,Europe,America and south Asia,supplying obsolete and hard-to-find components to meet their specific needs.

With the principle of “Quality Parts,Customers Priority,Honest Operation,and Considerate Service”,our business mainly focus on the distribution of electronic components. Line cards we deal with include Microchip,ALPS,ROHM,Xilinx,Pulse,ON,Everlight and Freescale. Main products comprise IC,Modules,Potentiometer,IC Socket,Relay,Connector.Our parts cover such applications as commercial,industrial, and automotives areas.

We are looking forward to setting up business relationship with you and hope to provide you with the best service and solution. Let us make a better world for our industry!



Contact us

Tel: +86-755-8981 8866 Fax: +86-755-8427 6832

Email & Skype: info@chipsmall.com Web: www.chipsmall.com

Address: A1208, Overseas Decoration Building, #122 Zhenhua RD., Futian, Shenzhen, China



GKE Series

Dual Entry Safety Interlock Switches



DESCRIPTION

The GKE Series safety key-operated switch provides enhanced reliability for safety hard guarding applications in a compact, cost-effective package.

FEATURES

- Positive opening safety contacts
- Multiple contact configurations
- Rotating head allows actuator engagement from five orientations
- Double insulation per IEC 60947-5-1
- Choice of two standard actuators
- Small size
- Most global approvals: cULus, CE, (CCC applied for)

BENEFITS

- Designed to minimize intentional tampering or defeat
- Designed to meet application-specific needs
- Small-size provides a valuable solution where space is at a premium
- Designed for global acceptance

POTENTIAL APPLICATIONS

- Plastic molding equipment
- Packaging machinery
- Semiconductor manufacturing equipment
- Woodworking machinery
- Metal converting equipment
- Printing/paper finishing equipment

GKE Series

SPECIFICATIONS

Designation and Utilization Category		Rated Operational Current I _e (A) at Rated Operational Voltage U _e (V)						
		24 V	120 V	240 V	380 V	480 V	500 V	600 V
AC15	A500	—	6 A	3 A	1,9 A	1,5 A	1,4 A	—
AC15	A600	—	6 A	3 A	1,9 A	1,5 A	1,4 A	1,2 A
DC13	Q300	2,8 A	0,55 A	0,27 A	—	—	—	—

Rated thermal current (I _{th})	10 A	Sealing	IP66; NEMA 1, 12, 13
Rated impulse withstand (U _{imp})	2500 V	Pollution degree	3
Rated insulation voltage (U _i)	500 V, 600 V	Operating temperature range	-25 °C to 85 °C [-13 °F to 185 °F]
Short-circuit protective device (type/max. rating)	Class J fuse (10 A/600 V)	Mechanical life	1,000,000 operations
Conditional short-circuit current	1000 A	—	—

Complies with:

Low Voltage Directive 73/23/EEC, as amended by directive 93/68/EEC.

Machinery Directive 98/37/EEC only as the directives relate to the components being used in a safety function.

IEC/EN60947-5-1.

MOUNTING DIMENSIONS (For reference only mm [in])

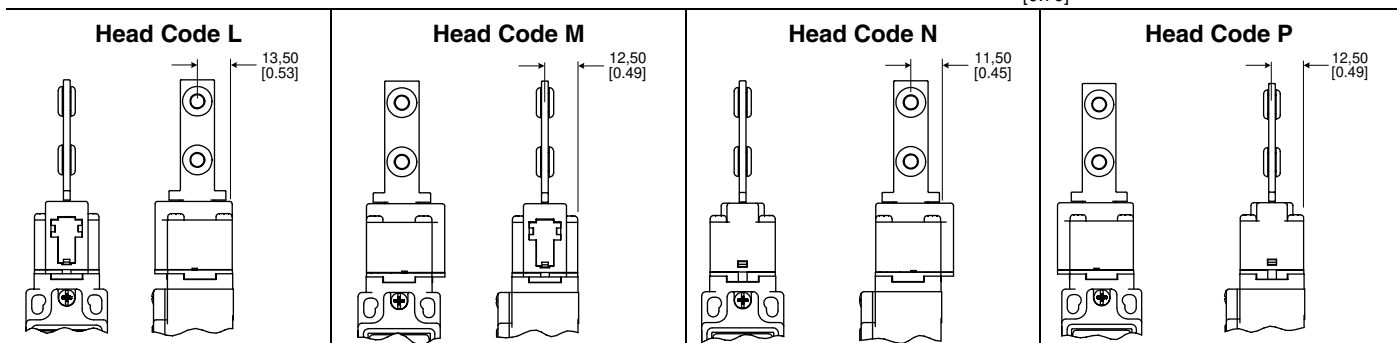
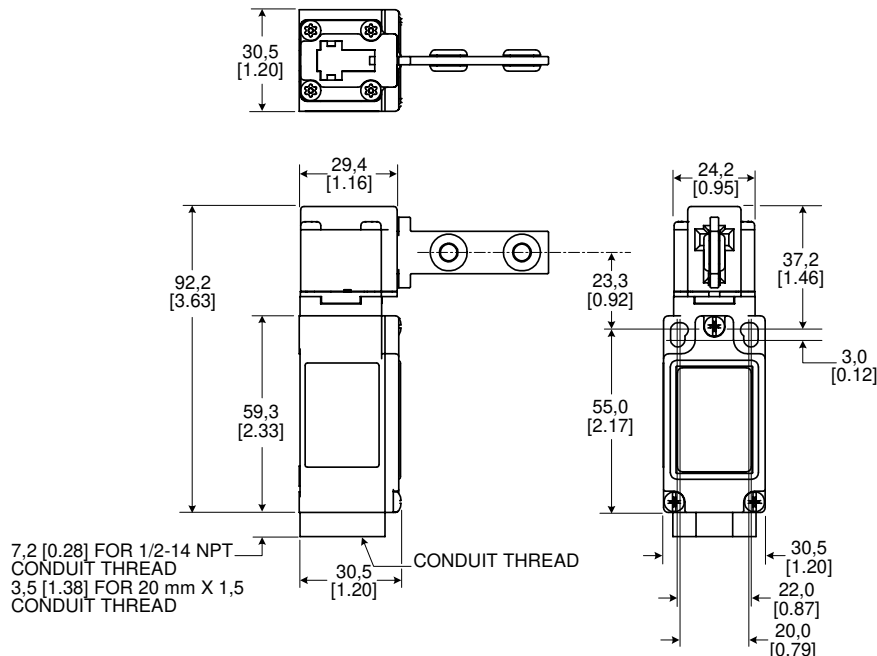

Safety Door Interlock Switches

KEY MOUNTING DIMENSIONS

GKZ51M	GKZ52M

1. Recommended key position.

CIRCUIT AND TRAVEL DIAGRAMS

Switch Code 01: 1NC/1NO	Switch Code 03: 1NC/1NO (BBM)	Switch Code 06: 2NC

1. Recommended key position.

SWITCH ORDER GUIDE (Not all combinations are active listings.)

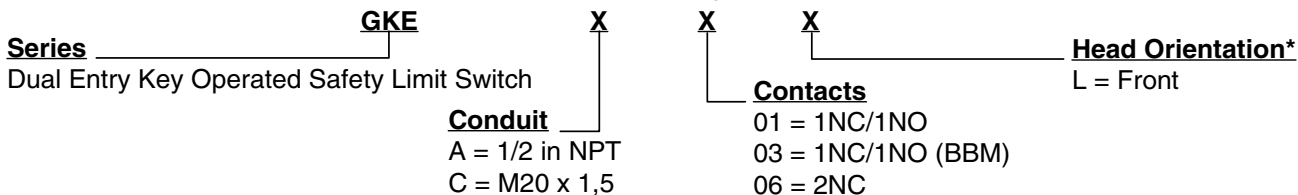

*Head orientation facing the right, left or back of the switch is available upon request. Minimum order quantities apply.

SWITCH ORDER GUIDE (active listings)

Catalog Listing	Description
GKEA01L	Dual Entry Key Operated Safety Limit Switch, ½ in NPT conduit, 1NC/1NO contacts, front head orientation
GKEA03L	Dual Entry Key Operated Safety Limit Switch, ½ in NPT conduit, 1NC/1NO (BBM) contacts, front head orientation
GKEA06L	Dual Entry Key Operated Safety Limit Switch, ½ in NPT conduit, 2NC contacts, front head orientation
GKEC01L	Dual Entry Key Operated Safety Limit Switch, M20 x 1,5 conduit, 1NC/1NO contacts, front head orientation
GKEC03L	Dual Entry Key Operated Safety Limit Switch, M20 x 1,5 conduit, 1NC/1NO (BBM) contacts, front head orientation
GKEC06L	Dual Entry Key Operated Safety Limit Switch, M20 x 1,5 conduit, 2NC contacts, front head orientation

KEY ORDER GUIDE

Catalog Listing	Description
GKZ51M	Straight Key
GKZ52M	90 Degree Key

⚠ WARNING
IMPROPER INSTALLATION

- Consult with local safety agencies and their requirements when designing a machine-control link, interface and all control elements that affect safety.
- Strictly adhere to all installation instructions.

Failure to comply with these instructions could result in death or serious injury.

WARRANTY/REMEDY
 Honeywell warrants goods of its manufacture as being free of defective materials and faulty workmanship. Honeywell's standard product warranty applies unless agreed to otherwise by Honeywell in writing; please refer to your order acknowledgement or consult your local sales office for specific warranty details. If warranted goods are returned to Honeywell during the period of coverage, Honeywell will repair or replace, at its option, without charge those items it finds defective. **The foregoing is buyer's sole remedy and is in lieu of all other warranties, expressed or implied, including those of merchantability and fitness for a particular purpose. In no event shall Honeywell be liable for consequential, special, or indirect damages.**

While we provide application assistance personally, through our literature and the Honeywell web site, it is up to the customer to determine the suitability of the product in the application.

Specifications may change without notice. The information we supply is believed to be accurate and reliable as of this printing. However, we assume no responsibility for its use.

Automation and Control Solutions

Sensing and Control
 Honeywell
 1985 Douglas Drive North
 Golden Valley, MN 55422
www.honeywell.com/sensing

⚠ WARNING
MISUSE OF DOCUMENTATION

- The information presented in this product sheet is for reference only. Do not use this document as a product installation guide.
- Complete installation, operation, and maintenance information is provided in the instructions supplied with each product.

Failure to comply with these instructions could result in death or serious injury.

SALES AND SERVICE
 Honeywell serves its customers through a worldwide network of sales offices, representatives and distributors. For application assistance, current specifications, pricing or name of the nearest Authorized Distributor, contact your local sales office or:

- E-mail:** info.sc@honeywell.com
- Internet:** www.honeywell.com/sensing
- Phone and Fax:**
 - Asia Pacific +65 6355-2828
+65 6445-3033 Fax
 - Europe +44 (0) 1698 481481
+44 (0) 1698 481676 Fax
 - Latin America +1-305-805-8188
+1-305-883-8257 Fax
 - USA/Canada +1-800-537-6945
+1-815-235-6847
+1-815-235-6545 Fax

