



Chipsmall Limited consists of a professional team with an average of over 10 year of expertise in the distribution of electronic components. Based in Hongkong, we have already established firm and mutual-benefit business relationships with customers from,Europe,America and south Asia,supplying obsolete and hard-to-find components to meet their specific needs.

With the principle of "Quality Parts,Customers Priority,Honest Operation,and Considerate Service",our business mainly focus on the distribution of electronic components. Line cards we deal with include Microchip,ALPS,ROHM,Xilinx,Pulse,ON,Everlight and Freescale. Main products comprise IC,Modules,Potentiometer,IC Socket,Relay,Connector.Our parts cover such applications as commercial,industrial, and automotives areas.

We are looking forward to setting up business relationship with you and hope to provide you with the best service and solution. Let us make a better world for our industry!



Contact us

Tel: +86-755-8981 8866 Fax: +86-755-8427 6832

Email & Skype: info@chipsmall.com Web: www.chipsmall.com

Address: A1208, Overseas Decoration Building, #122 Zhenhua RD., Futian, Shenzhen, China



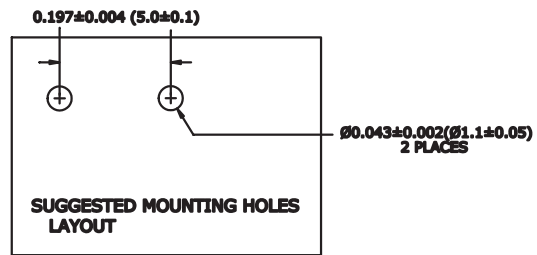
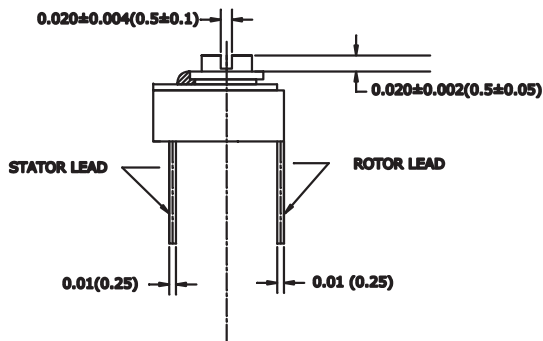
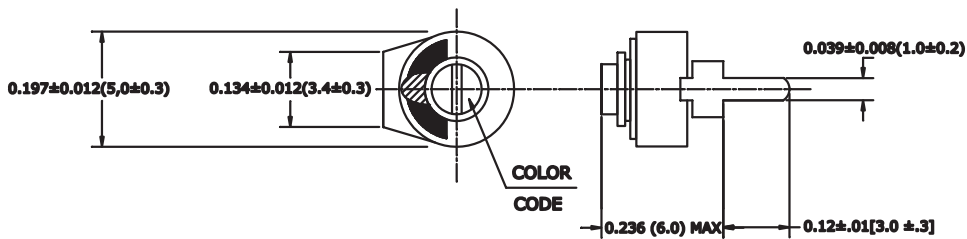

REV	DESCRIPTION	DATE	APP
00	NEW DWG	02/07/08	M.K.

SPECIFICATIONS

PART NUMBER	CAPACITANCE(pF)		TEMP. COEFF.	Q Factor	COLOR CODE
	Min.	Max.	ppm/C°	@ 10MHz	
GKU4R001	1.5	4.0	NPO±250	300Min	BLACK
GKU6R001	1.8	6.0	NPO±250	300Min	RED
GKU10001	2.8	12.5	N600±300	300Min	NONE
GKU20001	3.5	20	N750±300	300Min	BLUE
GKU30001	5.0	30	N1500±500	200Min (1MHZ)	YELLOW
GKU50001	9.0	50.0	N1500±500	200Min (1MHZ)	GREEN

NOTES:

1. WORKING VOLTAGE: 250VDC @ 85°C
2. DIELECTRIC WITHSTANDING: 400VDC
3. INSULATION RESISTANCE: >10¹⁰ Megohms @ 200VDC
4. TUNING TORQUE: 35-200g-cm (0.49-2.8oz-in)

TOLERANCES: (EXCEPT AS NOTED)		SPRAGUE GOODMAN ELECTRONICS INC. 1700 SHAMES DRIVE WESTBURY, NY 11590	
DECIMAL: ±.002 in ±.05 mm	MATERIAL:	SCALE NONE	DRAWN BY: M.KUVATOV APPROVED: D.DITLYA
FRACTIONAL: 1/64	TITLE: OUTLINE DWG GKU---01 SERIES		USED FOR:
ANGULAR: 1°	DATE: 02/07/08	DRAWING NUMBER: 7078	REV: 00