



Chipsmall Limited consists of a professional team with an average of over 10 year of expertise in the distribution of electronic components. Based in Hongkong, we have already established firm and mutual-benefit business relationships with customers from,Europe,America and south Asia,supplying obsolete and hard-to-find components to meet their specific needs.

With the principle of “Quality Parts,Customers Priority,Honest Operation,and Considerate Service”,our business mainly focus on the distribution of electronic components. Line cards we deal with include Microchip,ALPS,ROHM,Xilinx,Pulse,ON,Everlight and Freescale. Main products comprise IC,Modules,Potentiometer,IC Socket,Relay,Connector.Our parts cover such applications as commercial,industrial, and automotives areas.

We are looking forward to setting up business relationship with you and hope to provide you with the best service and solution. Let us make a better world for our industry!



## Contact us

Tel: +86-755-8981 8866 Fax: +86-755-8427 6832

Email & Skype: info@chipsmall.com Web: www.chipsmall.com

Address: A1208, Overseas Decoration Building, #122 Zhenhua RD., Futian, Shenzhen, China



### MULTIPLE OUTPUT GLOBAL PERFORMANCE SWITCHERS

#### Summary:

- 65 Watt Wide Range Input
- High Efficiency (Up to 90%)
- Universal input 90-264 Vac
- 2-year warranty
- Also available in single outputs
- Conducted EMI complies with FCC Class B and CISPR 22 Class B (Commercial models) and CISPR 11 Class B (Medical models)
- Exempt from line harmonics standard EN61000-3-2
- Commercial Approved to UL1950, CSA-C22.2 No. 950,
- Medical Approved to UL2601-1, CSA 22.2 No. 601.1, and EN60601-1- Medical Approved to UL2601-1, CSA 22.2 No. 601.1,
- RoHS Compliant (G suffix)
-  marked to LVD



#### SPECIFICATIONS

| <p><b>Ac Input</b><br/>90-264 Vac, 47-63 Hz single phase.</p>  | <p><b>Minimum Load</b><br/>No minimum load required on any output. However, regulation limits may be exceeded if extreme conditions are applied. Contact factory for assistance.</p>  |             |              |                           |                              |                           |                              |                  |                      |                         |                      |                        |                      |                      |                      |                             |                      |                       |              |                          |   |
|--|---|-------------|--------------|---------------------------|------------------------------|---------------------------|------------------------------|------------------|----------------------|-------------------------|----------------------|------------------------|----------------------|----------------------|----------------------|-----------------------------|----------------------|-----------------------|--------------|--------------------------|---|
| <p><b>Output Power</b><br/>Total continuous output power is 60 W, 75 W peak for 60 s 10% duty cycle. Total continuous rating with 150 LFM of air is 70 W.</p>  | <p><b>Temperature Coefficient:</b> 0.03%/°C typical on all outputs.</p>   |             |              |                           |                              |                           |                              |                  |                      |                         |                      |                        |                      |                      |                      |                             |                      |                       |              |                          |   |
| <p><b>Input Current</b><br/>Units are exempt from input current harmonic requirements of EN61000-3-2 when output power is less than 62W. Maximum input current at minimum input voltage and output overload will be less than 2.0 A.</p>                       | <p><b>Voltage Adjustment</b><br/>Units provided with one potentiometer capable of adjusting all 3 outputs a minimum of +/- 5% from nominal setting.</p>   |             |              |                           |                              |                           |                              |                  |                      |                         |                      |                        |                      |                      |                      |                             |                      |                       |              |                          |   |
| <p><b>Inrush Current</b><br/>Inrush is limited by internal thermistor. The inrush at 240 Vac, averaged over the first ac half-cycle under cold start conditions will not exceed 37 A.</p>  | <p><b>EMI / EMC Compliance:</b><br/>All models include built-in EMI filtering to meet EMC requirements of IEC601-1-2.</p>   |             |              |                           |                              |                           |                              |                  |                      |                         |                      |                        |                      |                      |                      |                             |                      |                       |              |                          |   |
| <p><b>Input Protection</b><br/>Internal AC fuse provided on all units. Designed to blow only if a catastrophic failure occurs in the unit -- Fuse does not blow on short circuit or unsustained overload.</p>  | <table border="1"> <thead> <tr> <th>PERFORMANCE</th> <th>EMC STANDARD</th> </tr> </thead> <tbody> <tr> <td>Conducted Emissions GLC65</td> <td>EN55022 Class B; FCC Class B</td> </tr> <tr> <td>Conducted Emissions GLM65</td> <td>EN55011 Class B; FCC Class B</td> </tr> <tr> <td>Static Discharge</td> <td>EN61000-4-2, Level 3</td> </tr> <tr> <td>RF Field Susceptibility</td> <td>EN61000-4-3, Level 3</td> </tr> <tr> <td>Fast Transients/Bursts</td> <td>EN61000-4-4, Level 3</td> </tr> <tr> <td>Surge Susceptibility</td> <td>EN61000-4-5, Level 3</td> </tr> <tr> <td>Conducted RF Susceptibility</td> <td>EN61000-4-6, 3V, 80%</td> </tr> <tr> <td>Voltage Sags &amp; Surges</td> <td>EN61000-4-11</td> </tr> <tr> <td>Line Frequency Harmonics</td> <td>EN61000-3-2 Class A (&gt;62Wout)<br/>Exempt (&lt;62Wout)</td> </tr> </tbody> </table> | PERFORMANCE | EMC STANDARD | Conducted Emissions GLC65 | EN55022 Class B; FCC Class B | Conducted Emissions GLM65 | EN55011 Class B; FCC Class B | Static Discharge | EN61000-4-2, Level 3 | RF Field Susceptibility | EN61000-4-3, Level 3 | Fast Transients/Bursts | EN61000-4-4, Level 3 | Surge Susceptibility | EN61000-4-5, Level 3 | Conducted RF Susceptibility | EN61000-4-6, 3V, 80% | Voltage Sags & Surges | EN61000-4-11 | Line Frequency Harmonics | EN61000-3-2 Class A (>62Wout)<br>Exempt (<62Wout) |
| PERFORMANCE  | EMC STANDARD  |             |              |                           |                              |                           |                              |                  |                      |                         |                      |                        |                      |                      |                      |                             |                      |                       |              |                          |   |
| Conducted Emissions GLC65  | EN55022 Class B; FCC Class B  |             |              |                           |                              |                           |                              |                  |                      |                         |                      |                        |                      |                      |                      |                             |                      |                       |              |                          |   |
| Conducted Emissions GLM65  | EN55011 Class B; FCC Class B  |             |              |                           |                              |                           |                              |                  |                      |                         |                      |                        |                      |                      |                      |                             |                      |                       |              |                          |   |
| Static Discharge   | EN61000-4-2, Level 3  |             |              |                           |                              |                           |                              |                  |                      |                         |                      |                        |                      |                      |                      |                             |                      |                       |              |                          |   |
| RF Field Susceptibility  | EN61000-4-3, Level 3  |             |              |                           |                              |                           |                              |                  |                      |                         |                      |                        |                      |                      |                      |                             |                      |                       |              |                          |   |
| Fast Transients/Bursts   | EN61000-4-4, Level 3  |             |              |                           |                              |                           |                              |                  |                      |                         |                      |                        |                      |                      |                      |                             |                      |                       |              |                          |   |
| Surge Susceptibility   | EN61000-4-5, Level 3  |             |              |                           |                              |                           |                              |                  |                      |                         |                      |                        |                      |                      |                      |                             |                      |                       |              |                          |   |
| Conducted RF Susceptibility  | EN61000-4-6, 3V, 80%  |             |              |                           |                              |                           |                              |                  |                      |                         |                      |                        |                      |                      |                      |                             |                      |                       |              |                          |   |
| Voltage Sags & Surges  | EN61000-4-11  |             |              |                           |                              |                           |                              |                  |                      |                         |                      |                        |                      |                      |                      |                             |                      |                       |              |                          |   |
| Line Frequency Harmonics   | EN61000-3-2 Class A (>62Wout)<br>Exempt (<62Wout)   |             |              |                           |                              |                           |                              |                  |                      |                         |                      |                        |                      |                      |                      |                             |                      |                       |              |                          |   |
| <p><b>Holdup Time</b><br/>Output voltage stays within regulation for 20 ms from loss of ac input at 65 W load, from 120 Vac input.</p>   | <p><b>Commercial Leakage Current</b><br/>Less than 500 µA @ 120 Vac. Less than 1.2 mA @ 240 Vac.</p>  |             |              |                           |                              |                           |                              |                  |                      |                         |                      |                        |                      |                      |                      |                             |                      |                       |              |                          |   |
| <p><b>Efficiency</b><br/>80% minimum.</p>  | <p><b>GLM65 Medical - Safety</b><br/>Approvals: All models are certified to be in compliance with the applicable requirements of UL2601-1, CSA 22.2 No. 601.1, IEC 601-1 (1988), EN 60601-1: 1990.</p>  |             |              |                           |                              |                           |                              |                  |                      |                         |                      |                        |                      |                      |                      |                             |                      |                       |              |                          |   |
| <p><b>Overload Protection</b><br/>Fully protected against short circuit and output overload. Short circuit protection is cycling type power limit and will automatically recover after removal of fault.</p>   | <p><b>Medical Leakage Current</b><br/>80 µA under normal conditions (132 Vac @ 60 Hz). Maximum under single fault conditions (264 Vac @ 60 Hz) is 180 µA.</p>   |             |              |                           |                              |                           |                              |                  |                      |                         |                      |                        |                      |                      |                      |                             |                      |                       |              |                          |   |
| <p><b>Overvoltage Protection</b><br/>Built in with firing point set. OVP firing reduces output to less than 50% of nominal voltage in less than 50 ms.</p>   |   |             |              |                           |                              |                           |                              |                  |                      |                         |                      |                        |                      |                      |                      |                             |                      |                       |              |                          |   |
| <p><b>Output Noise</b><br/>0.5% rms, 1% pk-pk, 20 MHz Bandwidth, differential mode. Measured with scope probe directly across output terminals of the power supply with load terminated with 1µF capacitor.</p>  |   |             |              |                           |                              |                           |                              |                  |                      |                         |                      |                        |                      |                      |                      |                             |                      |                       |              |                          |   |
| <p><b>Transient Response</b><br/>Main Output - 500 µs typical response time for return to within 0.5% of final value for a 50% load step within the regulation limits of minimum and maximum load, Δi/Δt &lt; 0.2 A/µs. Maximum voltage deviation is 3.5%.</p> |   |             |              |                           |                              |                           |                              |                  |                      |                         |                      |                        |                      |                      |                      |                             |                      |                       |              |                          |   |

| Commercial Model | Medical Model | Output No. | Output | Output Maximum (A) | Output Maximum (B) | Total Regulation (E) | V1 Adjustment Note (C) | OVP Set-point | Ripple/Noise |
|------------------|---------------|------------|--------|--------------------|--------------------|----------------------|------------------------|---------------|--------------|
| GLC65A           | GLM65A        | 1          | +5.0 V | 7 A                | 9 A                | 2%                   | ± 5%                   | 6.2 ± 0.6 V   | 1%           |
|                  |               | 2          | +12 V  | 3 A                | 5 A                | 5%                   | —                      | —             | 1%           |
|                  |               | 3          | -12 V  | 2.5 A              | 4 A                | 6%                   | —                      | —             | 1%           |
| GLC65B           | GLM65B        | 1          | +5.1 V | 7 A                | 9 A                | 2%                   | ± 5%                   | 6.2 ± 0.6 V   | 1%           |
|                  |               | 2          | +15 V  | 2.5 A              | 4 A                | 4%                   | —                      | —             | 1%           |
|                  |               | 3          | -15 V  | 2 A                | 3 A                | 5%                   | —                      | —             | 1%           |
| GLC65D           | GLM65D        | 1          | +5.0 V | 7 A                | 9 A                | 2%                   | ± 5%                   | 6.2 ± 0.6 V   | 1%           |
|                  |               | 2          | +24 V  | 1.5 A              | 2.5 A              | 3%                   | —                      | —             | 1%           |
|                  |               | 3          | -12 V  | 2.5 A              | 4 A                | 6%                   | —                      | —             | 1%           |
| GLC65E           | GLM65E        | 1          | +5.0 V | 7 A                | 9 A                | 2%                   | ± 5%                   | 6.2 ± 0.6 V   | 1%           |
|                  |               | 2          | +24 V  | 1.5 A              | 2.5 A              | 3%                   | —                      | —             | 1%           |
|                  |               | 3          | +12 V  | 2.5 A              | 4 A                | 6%                   | —                      | —             | 1%           |
| GLC65G           | GLM65G        | 1          | +5.0 V | 5 A                | 8 A                | 3%                   | ± 5%                   | 6.2 ± 0.6 V   | 1%           |
|                  |               | 2          | +3.3 V | 4 A                | 5 A                | 3%                   | —                      | —             | 1%           |
|                  |               | 3          | +12 V  | 2.5 A              | 4 A                | 6%                   | —                      | —             | 1%           |
| GLC65H           | GLM65H        | 1          | +3.3 V | 5 A                | 8 A                | 3.5%                 | ± 5%                   | 4.3 ± 0.8 V   | 1%           |
|                  |               | 2          | +5.0 V | 4 A                | 6 A                | 4.5%                 | —                      | —             | 1%           |
|                  |               | 3          | +12 V  | 2.5 A              | 3 A                | 6%                   | —                      | —             | 1%           |

**Notes:**

- A. Continuous individual output ratings for unrestricted convection cooling. Combination of individual output loads must not exceed total power rating.
- B. Peak rating for 60 s 10% duty cycle or continuous rating 150 LFM forced air cooling.
- C. Adjustment on V1 varies all outputs simultaneously (1% on V1 @ 1% on V2 & V3).
- D. Total combined current of V1 & V2 not to exceed 12 A. Combination of individual output loads must not exceed total power rating.
- E. Total regulation is defined as maximum deviation from the initial set point. With all other outputs at 50% load, output under test can be varied from 0 to 100% load and varied to any ac line voltage. Initial set point is 1% on V1, 2% on V2 and 3% on V3
- F. Add "G" suffix to model number for RoHS compliant model.

**GLC65 MECHANICAL SPECIFICATIONS**

INPUT J1:  
AMP P/N 640445-3, .156 [3.96mm] CTR,  
0.045 [1.14mm] SQUARE PIN HEADER

PIN 3) AC NEUTRAL  
PIN 2) NO PIN  
PIN 1) AC LINE

OUTPUT J2:  
AMP P/N 640445-6, .156 [3.96mm] CTR,  
0.045 [1.14mm] SQUARE PIN HEADER

PIN 1-3) OUTPUT  
PIN 4-6) COMMON  
GND: 0.250" FASTON TAB

SENSE J3:  
AMP P/N 640456-2, .100 [2.54mm] CTR,  
0.025 [0.64mm] SQUARE PIN HEADER

PIN 1) +SENSE  
PIN 2) -SENSE

MATING CONNECTORS: AMP P/N

|        | HOUSING  | CONTACTS |
|--------|----------|----------|
| INPUT  | 640250-3 | 770476-1 |
| OUTPUT | 640250-6 | 770476-1 |
| SENSE  | 640440-2 | 770476-1 |

NOTE: 5A MAXIMUM RECOMMENDED CURRENT PER CONNECTOR PIN

WEIGHT: 5 OZ.  
[0.142 KG]

TOLERANCES:  
X.XX ± 0.030 (0.76MM)  
X.XXX ± 0.010 (0.25MM)

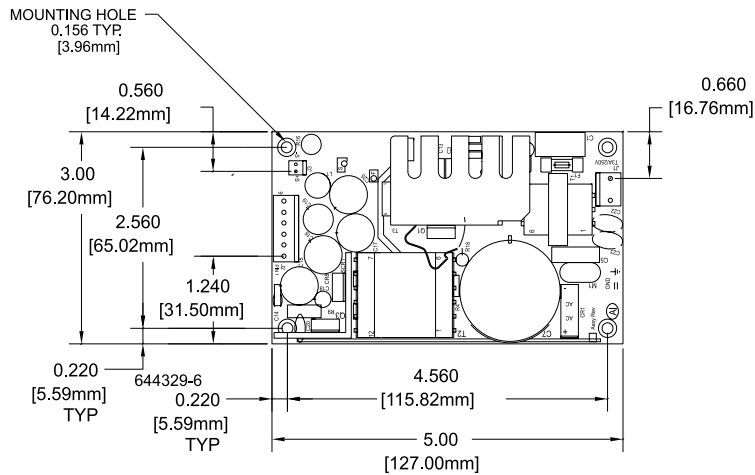

MAX. COMPONENT HEIGHT 1.20" [30.28mm]  
MAX. LEAD PROTRUSION 0.10" [2.54mm]

A. Units should be allowed to warm up/operate under non-condensing conditions before application of power. Derate output current and total output power by 2.5% per °C above 50°C. For operation in a confined space, moving air may be required. Under all conditions, the cooling vs. load profile should be such that heat sinks and/or heatsink temperatures do not exceed 90 °C for extended periods.

B. Shock testing—half-sinusoidal, 10 ± 3 ms duration, ± direction, 3 orthogonal axes, total 6 shocks.

C. Random vibration—10 to 2000Hz, 6dB/octave roll-off from 350 to 2000Hz, 3 orthogonal axes. Tested for 10 min./axis operating and 1 hr./axis non-operating.

| ENVIRONMENTAL SPECIFICATIONS | OPERATING                                       | NON-OPERATING                                 |
|------------------------------|---|---|
| Temperature (A)              | 0 TO 50°C                                       | -40 to +85°C                                  |
| Humidity (A)                 | 0 to 95% RH                                     | 0 to 95% RH                                   |
| Shock (B)                    | 20 g <sub>pk</sub>                              | 40 g <sub>pk</sub>                            |
| Altitude                     | -500 to 10,000 ft                               | -500 to 40,000 ft                             |
| Vibration (C)                | 1.5 g <sub>rms</sub> , 0.003 g <sup>2</sup> /Hz | 5 g <sub>rms</sub> , 0.026 g <sup>2</sup> /Hz |