



Chipsmall Limited consists of a professional team with an average of over 10 year of expertise in the distribution of electronic components. Based in Hongkong, we have already established firm and mutual-benefit business relationships with customers from,Europe,America and south Asia,supplying obsolete and hard-to-find components to meet their specific needs.

With the principle of “Quality Parts,Customers Priority,Honest Operation,and Considerate Service”,our business mainly focus on the distribution of electronic components. Line cards we deal with include Microchip,ALPS,ROHM,Xilinx,Pulse,ON,Everlight and Freescale. Main products comprise IC,Modules,Potentiometer,IC Socket,Relay,Connector.Our parts cover such applications as commercial,industrial, and automotives areas.

We are looking forward to setting up business relationship with you and hope to provide you with the best service and solution. Let us make a better world for our industry!



Contact us

Tel: +86-755-8981 8866 Fax: +86-755-8427 6832

Email & Skype: info@chipsmall.com Web: www.chipsmall.com

Address: A1208, Overseas Decoration Building, #122 Zhenhua RD., Futian, Shenzhen, China



GP1FA512TZ/ GP1FA512RZ

■ Features

1. Shutter system unnecessary to remove the protection cap
2. Uni-directional data transmission using plastic optical fiber
3. High transfer rate: $T=13.2\text{Mb/s}$
4. The optical receiver can be directly connectable the TTL, due to the use of *OPIC

■ Applications

1. DVD players
2. STB
3. AV amplifier

■ Absolute Maximum Ratings ($T_a=25^\circ\text{C}$)

Parameter	Symbol	Rating	Unit
Supply voltage	V_{CC}	-0.5 to +7.0	V
Output current (GP1FA512RZ)	I_{OH}	2 (Source current)	mA
	I_{OL}	10 (Sink current)	
Input voltage (GP1FA512TZ)	V_{IN}	-0.5 to $V_{CC}+0.5$	V
Operating temperature	T_{opr}	-20 to +70	$^\circ\text{C}$
Storage temperature	T_{stg}	-30 to +80	$^\circ\text{C}$
*1 Soldering temperature	T_{sol}	260	$^\circ\text{C}$

*1 For 5s (2 times or less)

Shutter System Fiber Optic Transmitter/ Receiver

■ Outline Dimensions

(Unit : mm)

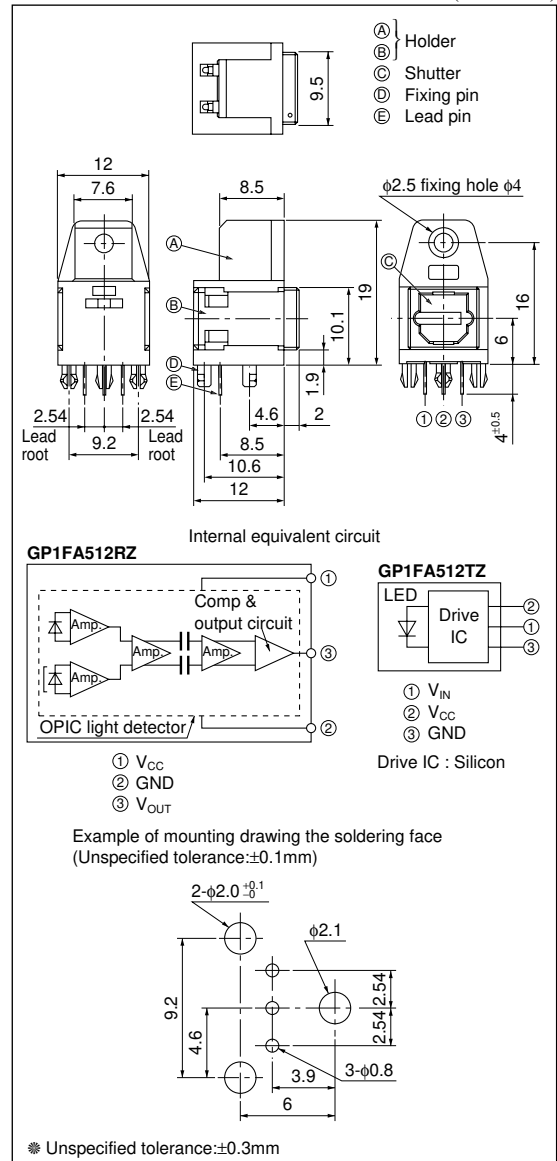

* "OPIC" (Optical IC) is a trademark of the SHARP Corporation. An OPIC consists of a light-detecting element and signal-processing circuit integrated onto a single chip.

■ Recommended Operating Conditions (GP1FA512TZ) (T_a=25°C)

Parameter	Symbol	MIN.	TYP.	MAX.	Unit
Operating supply voltage	V _{CC}	4.75	5.0	5.25	V
*2 Operating transfer rate	T	–	–	13.2	Mb/s

*2 NRZ signal duty 50%

■ Recommended Operating Conditions (GP1FA512RZ) (T_a=25°C)

Parameter	Symbol	MIN.	TYP.	MAX.	Unit
Operating supply voltage	V _{CC}	4.75	5.0	5.25	V
*3*4 Operating transfer rate	T	0.1	–	13.2	Mb/s
*5 Input optical power level	P _C	–24	–	–14.5	dBm

*3 The above operating transfer rate is the value when NRZ signal, "0101..." continuous signal of duty 50% is transmitted

*4 The output (H/L level) of GP1FA512RZ are not fixed constantly when it receives the modulating light (including DC light, no input light) less than 0.1Mb/s

*5 Peak optical output

■ Electro-optical Characteristics (GP1FA512TZ) (T_a=25°C, V_{CC}=5V)

Parameter	Symbol	Conditions	MIN.	TYP.	MAX.	Unit
Peak emission wavelength	λ _p	–	630	660	690	nm
Optical power output coupling with fiber	P _C	Refer to Fig.1	–21	–18	–15	dBm
Dissipation current	I _{CC}	Refer to Fig.2	–	8	13	mA
High level input voltage	V _{IH}	Refer to Fig.2	2.1	–	–	V
Low level input voltage	V _{IL}	Refer to Fig.2	–	–	0.8	V
Low→High delay time	t _{pLH}	Refer to Fig.3	–	–	180	ns
High→Low delay time	t _{pHL}	Refer to Fig.3	–	–	180	ns
Pulse width distortion	Δt _w	Refer to Fig.3	–15	–	+15	ns
Jitter	Δt _j	Refer to Fig.3	–	1	15	ns

■ Electro-optical Characteristics (GP1FA512RZ) (T_a=25°C, V_{CC}=5V)

Parameter	Symbol	Conditions	MIN.	TYP.	MAX.	Unit
Peak sensitivity wavelength	λ _p	–	–	700	–	nm
Dissipation current	I _{CC}	Refer to Fig.4	–	15	25	mA
High level output voltage	V _{OH}	Refer to Fig.5	2.7	3.5	–	V
Low level output voltage	V _{OL}	Refer to Fig.5	–	0.2	0.4	V
Rise time	t _r	Refer to Fig.5	–	17	23	ns
Fall time	t _f	Refer to Fig.5	–	7	15	ns
Low→High delay time	t _{pLH}	Refer to Fig.5	–	–	180	ns
High→Low delay time	t _{pHL}	Refer to Fig.5	–	–	180	ns
Pulse width distortion	Δt _w	Refer to Fig.5	–20	–	+20	ns
Jitter	Δt _j	Refer to Fig.6, P _C =–14.5dBm	–	1	15	ns
		Refer to Fig.6, P _C =–24dBm	–	–	15	ns

■ Mechanical Characteristics

Parameter	Symbol	Conditions	MIN.	TYP.	MAX.	Unit
Insertion force, withdrawal force	–	Initial value when a GP1C331 is used	6	–	40	N

Fig.1 Measuring Method of Optical Output Coupling with Fiber

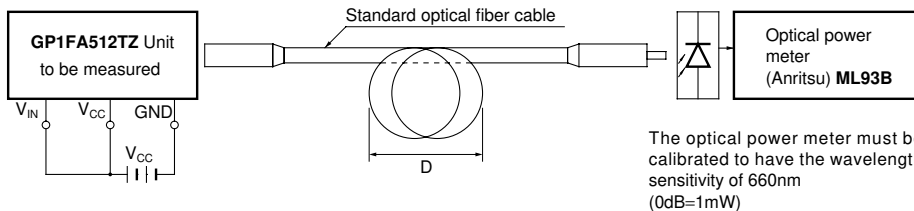

- Note (1) V_{CC} :5.0V (State of operating)
 (2) To bundle up the standard fiber optic cable, make it into a loop with the diameter $D=10$ cm or more (The standard fiber optic cable will be specified elsewhere.)

Fig.2 Measuring Method of Input Voltage and Supply Current

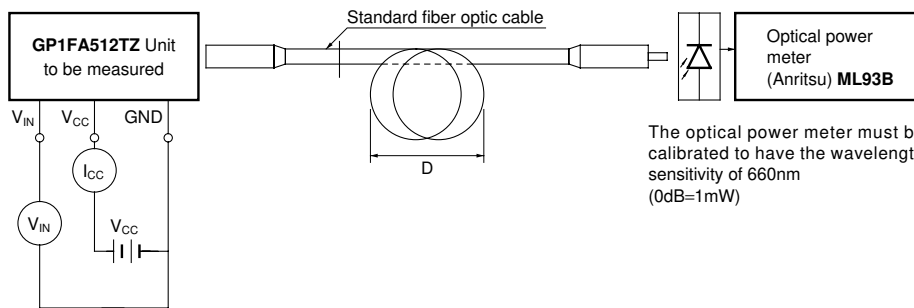

Input conditions and judgement method

Conditions	Judgement method
$V_{IN}=2.1V$ or more	$-21 \leq P_C \leq -15dBm$, $I_{CC}=13mA$ or less
$V_{IN}=0.8V$ or less	$P_C \leq -36dBm$, $I_{CC}=13mA$ or less

Note $V_{CC}=5.0V$ (State of operating)

Fig.3 Measuring Method of Pulse Response and Jitter

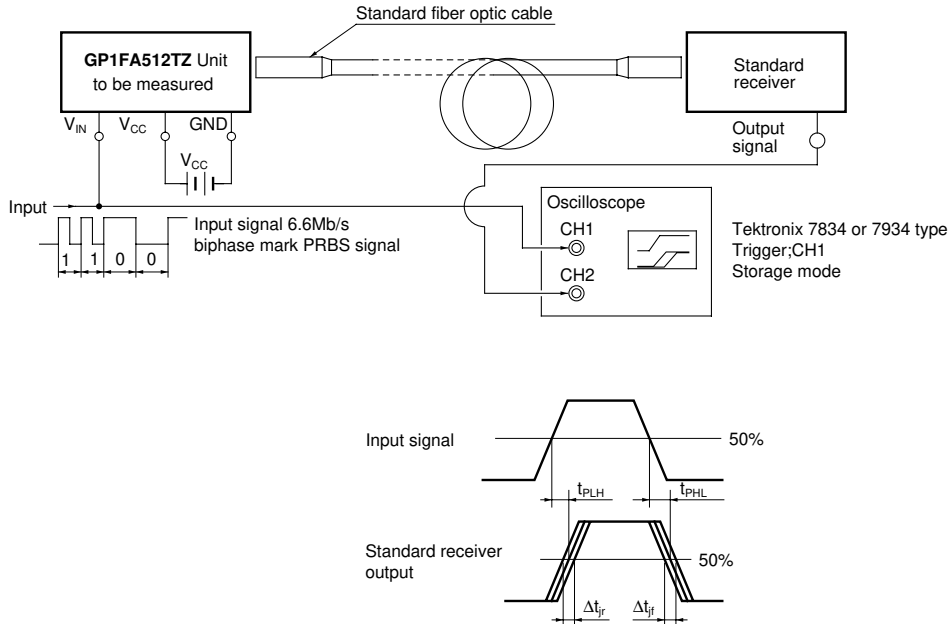

Parameter	Symbol	Conditions
Low→High delay time	t_{pLH}	Refer to the above mentioned prescription
High→Low delay time	t_{pHL}	Refer to the above mentioned prescription
Pulse width distortion	Δt_w	$\Delta t_w = t_{pHL} - t_{pLH}$
Low→High jitter	Δt_{jr}	Set the trigger on the rise of input signal to measure the jitter of the rise of output
High→Low jitter	Δt_{jl}	Set the trigger on the fall of input signal to measure the jitter of the fall of output

- Notes (1) The waveform write time shall be 4s. But do not allow the waveform to be distorted by increasing the brightness too much
 (2) $V_{CC}=5.0V$ (State of operating)
 (3) The probe for the oscilloscope must be more than $1M\Omega$ and less than $10pF$

Fig.4 Supply Current

Input conditions		Measuring method
Supply voltage	$V_{CC}=5.0V$	Measured on an ammeter (DC average amperage)
Fiber coupling light output	$P_C=-14.5dBm$	
Standard transmitter input signal	13.2Mb/s NRZ, Duty 50% or 6.6Mb/s biphasic mark PRBS signal	

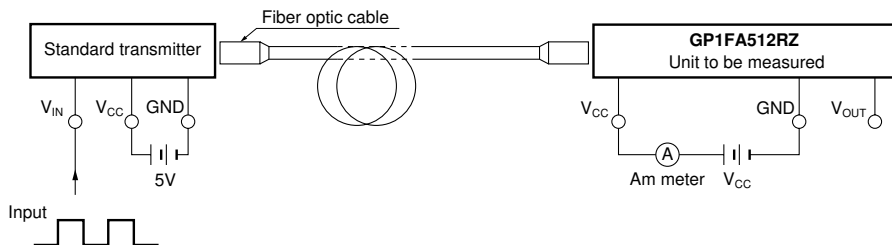
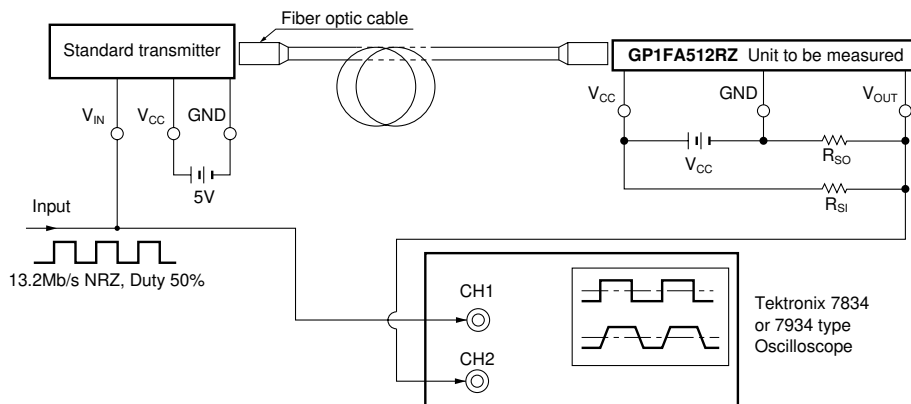

Fig.5 Measuring Method of Output Voltage and Pulse Response



Test item

Test item	Symbol
Low → High pulse delay time	t_{pLH}
High → Low pulse delay time	t_{pHL}
Rise time	t_r
Fall time	t_f
Pulse width distortion $\Delta t_w = t_{pHL} - t_{pLH}$	Δt_w
High level output voltage	V_{OH}
Low level output voltage	V_{OL}

- Notes (1) $V_{CC} = 5.0V$ (State of operating)
 (2) The fiber coupling light output set at $-14.5dBm/-24dBm$
 (3) The probe for the oscilloscope must be more than $1M\Omega$ and less than $10pF$
 (4) R_{SI} , R_{SO} : Standard load resistance ($R_{SI}: 3.3k\Omega$, $R_{SO}: 2.2k\Omega$)
 (5) The output (H/L level) of **GP1FA512RZ** are not fixed constantly when it receives the modulating light (including DC light, no input light) less than $0.1Mb/s$

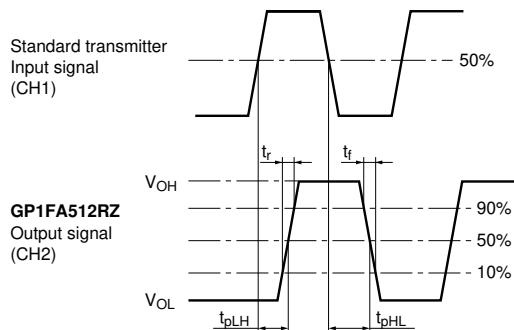
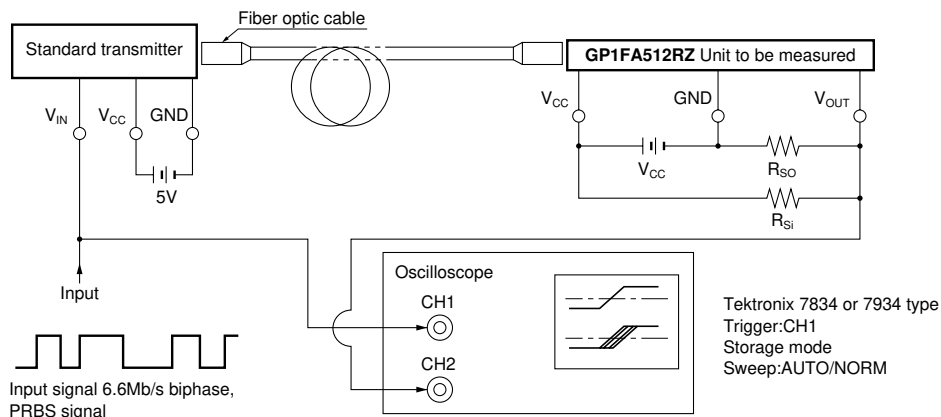

Fig.6 Measuring Method of Jitter



Test item

Test item	Symbol	Test condition
Jitter	Δt_j	Set the trigger on the rise of input signal to measure the jitter of the rise of output
Jitter	Δt_j	Set the trigger on the fall of input signal to measure the jitter of the fall of output

- Notes (1) The fiber coupling light output set at $-14.5\text{dBm}/-24\text{dBm}$
 (2) R_{SI} , R_{SO} : Standard load resistance (R_{SI} : $3.3\text{k}\Omega$, R_{SO} : $2.2\text{k}\Omega$)
 (3) The waveform write time shall be 3s. But do not allow the waveform to be distorted by increasing the brightness too much
 (4) $V_{CC}=5.0\text{V}$ (State of operating)
 (5) The probe for the oscilloscope must be more than $1\text{M}\Omega$ and less than 10pF

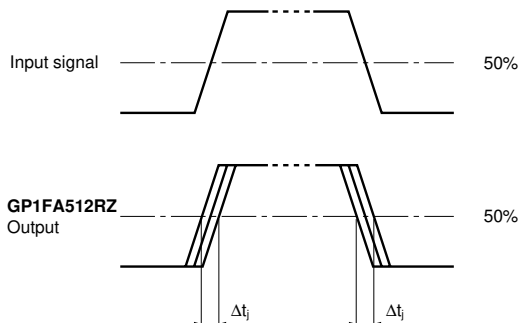

NOTICE

- The circuit application examples in this publication are provided to explain representative applications of SHARP devices and are not intended to guarantee any circuit design or license any intellectual property rights. SHARP takes no responsibility for any problems related to any intellectual property right of a third party resulting from the use of SHARP's devices.
- Contact SHARP in order to obtain the latest device specification sheets before using any SHARP device. SHARP reserves the right to make changes in the specifications, characteristics, data, materials, structure, and other contents described herein at any time without notice in order to improve design or reliability. Manufacturing locations are also subject to change without notice.
- Observe the following points when using any devices in this publication. SHARP takes no responsibility for damage caused by improper use of the devices which does not meet the conditions and absolute maximum ratings to be used specified in the relevant specification sheet nor meet the following conditions:
 - (i) The devices in this publication are designed for use in general electronic equipment designs such as:
 - Personal computers
 - Office automation equipment
 - Telecommunication equipment [terminal]
 - Test and measurement equipment
 - Industrial control
 - Audio visual equipment
 - Consumer electronics
 - (ii) Measures such as fail-safe function and redundant design should be taken to ensure reliability and safety when SHARP devices are used for or in connection with equipment that requires higher reliability such as:
 - Transportation control and safety equipment (i.e., aircraft, trains, automobiles, etc.)
 - Traffic signals
 - Gas leakage sensor breakers
 - Alarm equipment
 - Various safety devices, etc.
 - (iii) SHARP devices shall not be used for or in connection with equipment that requires an extremely high level of reliability and safety such as:
 - Space applications
 - Telecommunication equipment [trunk lines]
 - Nuclear power control equipment
 - Medical and other life support equipment (e.g., scuba).
- If the SHARP devices listed in this publication fall within the scope of strategic products described in the Foreign Exchange and Foreign Trade Law of Japan, it is necessary to obtain approval to export such SHARP devices.
- This publication is the proprietary product of SHARP and is copyrighted, with all rights reserved. Under the copyright laws, no part of this publication may be reproduced or transmitted in any form or by any means, electronic or mechanical, for any purpose, in whole or in part, without the express written permission of SHARP. Express written permission is also required before any use of this publication may be made by a third party.
- Contact and consult with a SHARP representative if there are any questions about the contents of this publication.