



Chipsmall Limited consists of a professional team with an average of over 10 year of expertise in the distribution of electronic components. Based in Hongkong, we have already established firm and mutual-benefit business relationships with customers from,Europe,America and south Asia,supplying obsolete and hard-to-find components to meet their specific needs.

With the principle of "Quality Parts,Customers Priority,Honest Operation,and Considerate Service",our business mainly focus on the distribution of electronic components. Line cards we deal with include Microchip,ALPS,ROHM,Xilinx,Pulse,ON,Everlight and Freescale. Main products comprise IC,Modules,Potentiometer,IC Socket,Relay,Connector.Our parts cover such applications as commercial,industrial, and automotives areas.

We are looking forward to setting up business relationship with you and hope to provide you with the best service and solution. Let us make a better world for our industry!



Contact us

Tel: +86-755-8981 8866 Fax: +86-755-8427 6832

Email & Skype: info@chipsmall.com Web: www.chipsmall.com

Address: A1208, Overseas Decoration Building, #122 Zhenhua RD., Futian, Shenzhen, China



GP1FD210RP

Thin Low Voltage Operation Type Optical Mini-jack for Digital Audio Equipment

■ Features

1. Thin type (4.2mm) fiber optic receiver
2. Compact (adoption of small jack for mini plug) JIS C6560
3. Both optical and electrical signal can be distinguished and received
4. Low voltage operation (V_{CC} 2.4 to 3.0V)
5. High speed data transmission
(Signal transmission speed : MAX, 8Mb/s (NRZ signal))

■ Applications

1. MD players
2. Portable CD players (Optic receiver part)

■ Absolute Maximum Ratings

(Photoelectric conversion element) ($T_a=25^\circ\text{C}$)

Parameter	Symbol	Rating	Unit
Supply voltage	V_{CC}	-0.5 to +7.0	V
Operating temperature	T_{opr}	-20 to +70	$^\circ\text{C}$
Storage temperature	T_{stg}	-30 to +80	$^\circ\text{C}$
*1 Soldering temperature (Reflow)	T_{sol}	240	$^\circ\text{C}$
Output current	I_{OH}	2 (source current)	mA
	I_{OL}	4 (sink current)	mA

*1 For 10s (according to reflow profile in the specification sheet)

■ Absolute Maximum Ratings(Jack)

Parameter	Symbol	Rating	Unit
Total power dissipation	P_{tot}	D.C. 12V, 1A	-
Operating temperature	T_{opr}	-20 to +70	$^\circ\text{C}$
Storage temperature	T_{stg}	-30 to +80	$^\circ\text{C}$
*1 Soldering temperature	T_{sol}	240	$^\circ\text{C}$
*2 Isolation voltage	V_{iso}	A.C. 500V _{rms}	-

*2 For 1minute

■ Outline Dimensions

(Unit : mm)

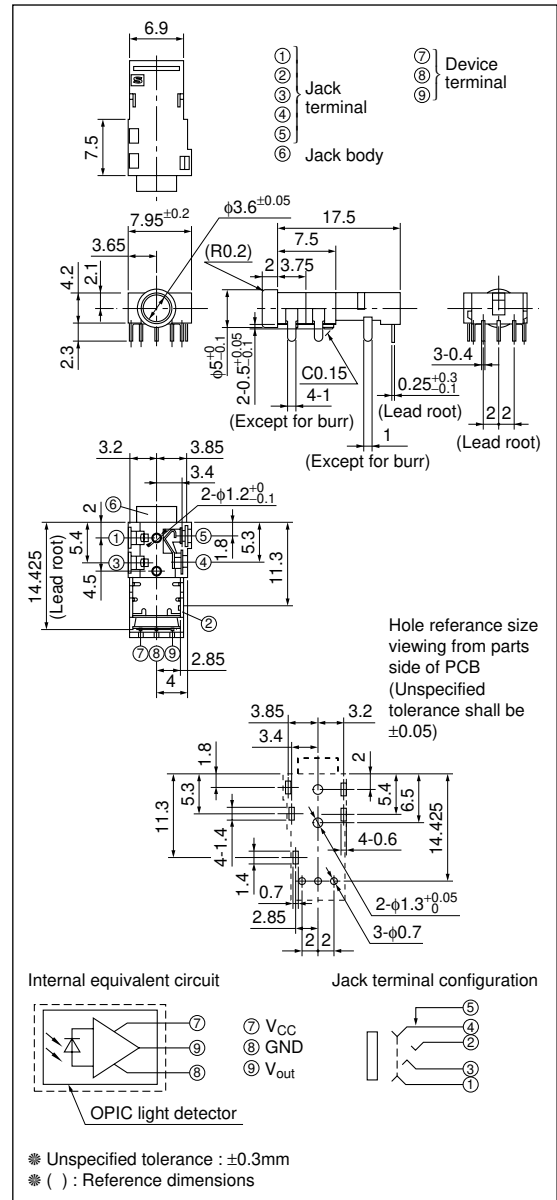

* "OPIC" (Optical IC) is a trademark of the SHARP Corporation.
An OPIC consists of a light-detecting element and signal-processing circuit integrated onto a signal chip.

■ Recommended Operating Conditions

Parameter	Symbol	MIN.	TYP.	MAX.	Unit
Operating supply voltage	V_{CC}	2.4	2.5	3.0	V
Operating transfer rate	T	0.1	—	8	Mb/s
Receiver input optical power level	P_C	-24.0	—	-14.5	dBm

■ Electro-optical Characteristics

($T_a=25^\circ\text{C}$, $V_{CC}=3.0\text{V}$)

Parameter	Symbol	Conditions	MIN.	TYP.	MAX.	Unit
Peak sensitivity wavelength	λ_p	—	—	700	—	nm
Dissipation current	I_{CC}	Refer to Fig.1	—	5	7.5	mA
High level output voltage	V_{OH}	Refer to Fig.2	2.0	2.2	—	V
Low level output voltage	V_{OL}	Refer to Fig.2	—	0.2	0.5	V
Rise time	t_r	Refer to Fig.2	—	17	—	ns
Fall time	t_f	Refer to Fig.2	—	5	—	ns
Low → High delay time	t_{pLH}	Refer to Fig.2	—	—	180	ns
High → Low delay time	t_{pHL}	Refer to Fig.2	—	—	180	ns
Pulse width distortion	Δt_w	Refer to Fig.2	-30	—	+30	ns
Jitter	Δt_j	Refer to Fig.3, $P_C=-14.5\text{dBm}$	—	1	30	ns
		Refer to Fig.p3, $P_C=-24\text{dBm}$	—	—	30	ns

■ Mechanical and Electrical Characteristics(Jack)

Parameter	Symbol	Conditions	MIN.	TYP.	MAX.	Unit
Insertion force, with drawal force	F_p	*3	5	—	35	N
Contact resistance	R_{con}	*4	—	—	30	m Ω
Isolation resistance	R_{iso}	D.C. 500V, 1minute	100	—	—	M Ω

Note) This jack is designed for applicable to $\phi 3.5$ compact single head plug (JIS C6560)

*3 Measuring method of insertion force and withdrawal force

Insertion and withdrawal force shall be measured after inserting and withdrawing 3 times by using JIS C6560 standard plug for test

*4 Measuring method of contact resistance

It measures at 100mA or less and 1 000Hz at the condition of inserting JIS C6560 standard plug for test in which movable contact terminal and make contacts are described

Fig.1 Dissipation Current

Input conditions		Measuring method
Supply voltage	$V_{CC}=2.5\text{V}$	Measured on an ammeter (DC average amperage)
Optical output coupling with fiber	$P_C=-14.5\text{dBm}$	
Standard transmitter input signal	6Mb/s NRZ, Duty 50% or 3Mb/s biphasic mark PRBS signal	

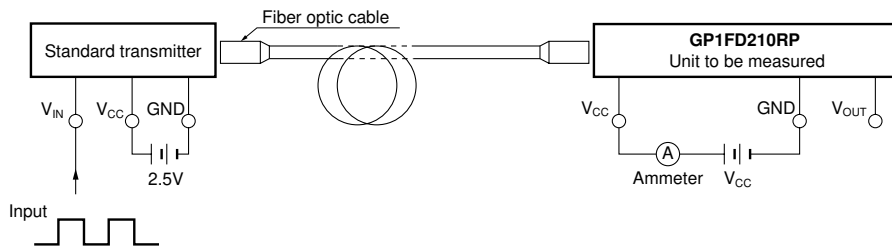
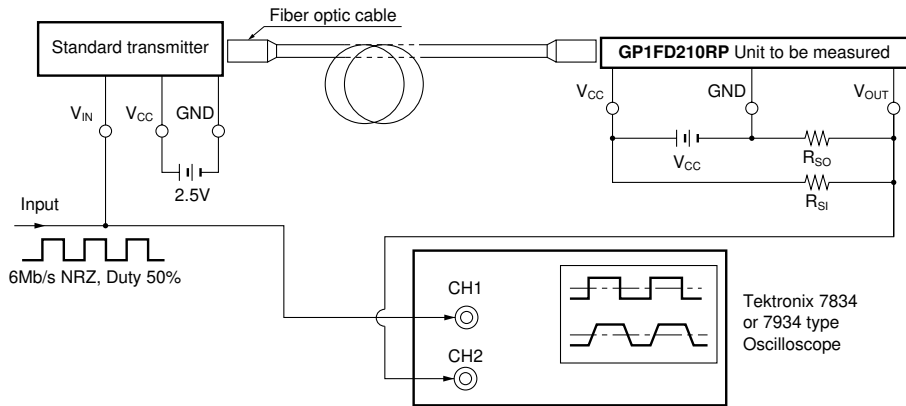

Fig.2 Measuring Method of Output Voltage and Pulse Response



Test item

Test item	Symbol
Low → High pulse delay time	t_{PLH}
High → Low pulse delay time	t_{PHL}
Rise time	t_r
Fall time	t_f
Pulse width distortion $\Delta t_w = t_{PHL} - t_{PLH}$	Δt_w
High level output voltage	V_{OH}
Low level output voltage	V_{OL}

- Notes (1) $V_{CC}=2.5V$ (State of operating)
 (2) The fiber coupling light output set at $-14.5dBm/-24.0dBm$
 (3) The probe for the oscilloscope must be more than $1M\Omega$ and less than $10pF$
 (4) The output (H/L level) of **GP1FD210RP** are not fixed constantly when it receives the modulating light (including DC light, no input light) less than $0.1Mb/s$

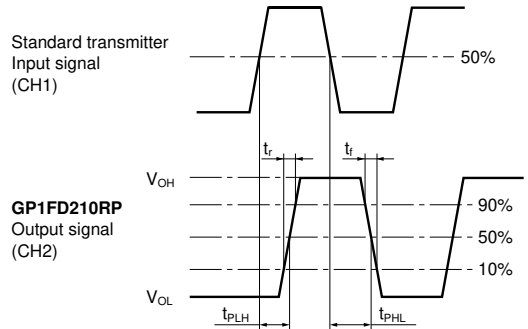
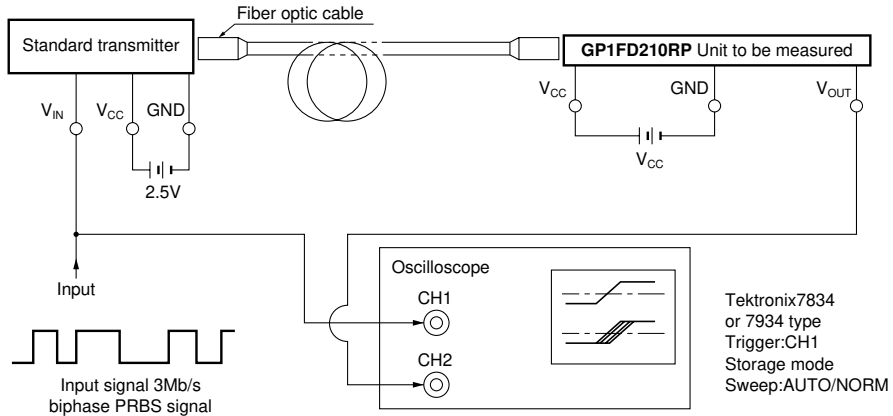

Fig.3 Measuring Method of Jitter



Test item

Test item	Symbol	Test condition
Jitter	Δt_j	Set the trigger on the rise of input signal to measure the jitter of the rise of output
Jitter	Δt_j	Set the trigger on the fall of input signal to measure the jitter of the fall of output

- Notes
- (1) The fiber coupling light output set at $-14.5\text{dBm}/-24.0\text{dBm}$
 - (2) The waveform write time shall be 3 seconds. But do not allow the waveform to be distorted by increasing the brightness too much
 - (3) $V_{CC}=2.5\text{V}$ (State of operating)
 - (4) The probe for the oscilloscope must be more than $1\text{M}\Omega$ and less than 10pF

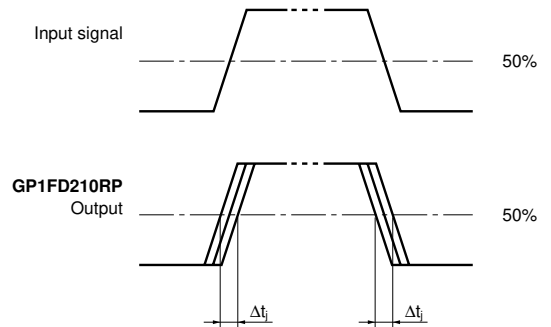

NOTICE

- The circuit application examples in this publication are provided to explain representative applications of SHARP devices and are not intended to guarantee any circuit design or license any intellectual property rights. SHARP takes no responsibility for any problems related to any intellectual property right of a third party resulting from the use of SHARP's devices.
- Contact SHARP in order to obtain the latest device specification sheets before using any SHARP device. SHARP reserves the right to make changes in the specifications, characteristics, data, materials, structure, and other contents described herein at any time without notice in order to improve design or reliability. Manufacturing locations are also subject to change without notice.
- Observe the following points when using any devices in this publication. SHARP takes no responsibility for damage caused by improper use of the devices which does not meet the conditions and absolute maximum ratings to be used specified in the relevant specification sheet nor meet the following conditions:
 - (i) The devices in this publication are designed for use in general electronic equipment designs such as:
 - Personal computers
 - Office automation equipment
 - Telecommunication equipment [terminal]
 - Test and measurement equipment
 - Industrial control
 - Audio visual equipment
 - Consumer electronics
 - (ii) Measures such as fail-safe function and redundant design should be taken to ensure reliability and safety when SHARP devices are used for or in connection with equipment that requires higher reliability such as:
 - Transportation control and safety equipment (i.e., aircraft, trains, automobiles, etc.)
 - Traffic signals
 - Gas leakage sensor breakers
 - Alarm equipment
 - Various safety devices, etc.
 - (iii) SHARP devices shall not be used for or in connection with equipment that requires an extremely high level of reliability and safety such as:
 - Space applications
 - Telecommunication equipment [trunk lines]
 - Nuclear power control equipment
 - Medical and other life support equipment (e.g., scuba).
- If the SHARP devices listed in this publication fall within the scope of strategic products described in the Foreign Exchange and Foreign Trade Law of Japan, it is necessary to obtain approval to export such SHARP devices.
- This publication is the proprietary product of SHARP and is copyrighted, with all rights reserved. Under the copyright laws, no part of this publication may be reproduced or transmitted in any form or by any means, electronic or mechanical, for any purpose, in whole or in part, without the express written permission of SHARP. Express written permission is also required before any use of this publication may be made by a third party.
- Contact and consult with a SHARP representative if there are any questions about the contents of this publication.