



Chipsmall Limited consists of a professional team with an average of over 10 year of expertise in the distribution of electronic components. Based in Hongkong, we have already established firm and mutual-benefit business relationships with customers from,Europe,America and south Asia,supplying obsolete and hard-to-find components to meet their specific needs.

With the principle of “Quality Parts,Customers Priority,Honest Operation,and Considerate Service”,our business mainly focus on the distribution of electronic components. Line cards we deal with include Microchip,ALPS,ROHM,Xilinx,Pulse,ON,Everlight and Freescale. Main products comprise IC,Modules,Potentiometer,IC Socket,Relay,Connector.Our parts cover such applications as commercial,industrial, and automotives areas.

We are looking forward to setting up business relationship with you and hope to provide you with the best service and solution. Let us make a better world for our industry!



Contact us

Tel: +86-755-8981 8866 Fax: +86-755-8427 6832

Email & Skype: info@chipsmall.com Web: www.chipsmall.com

Address: A1208, Overseas Decoration Building, #122 Zhenhua RD., Futian, Shenzhen, China



GP1FP513RK0F

Fiber Optic Receiver
Electric jack/Optical connector
integrated type
With mounting hole
With shutter



■Description

GP1FP513RK0F employs an OPIC device that integrates a photodiode and signal processing circuit onto a single chip.

■Features

1. Fiber optic receiver
(Transmitter : **GP1FP513TK0F**)
2. Electric jack/Optical connector integrated type
(Electric jack : JEITA RC-5231
Optical connector : JEITA RC-5720B)
3. With mounting hole
4. With shutter function
5. Supply voltage : 5 V
6. Transfer rate : 13.2 Mb/s

■Agency approvals/Compliance

1. Compliant with JEITA RC-5231, RC-5720B and CP1201
2. Compliant with RoHS directive (2002/95/EC)

■Applications

AV equipment
(DVD, CD, MD players etc.)

Notice The content of data sheet is subject to change without prior notice.

In the absence of confirmation by device specification sheets, SHARP takes no responsibility for any defects that may occur in equipment using any SHARP devices shown in catalogs, data books, etc. Contact SHARP in order to obtain the latest device specification sheets before using any SHARP device.

Sheet No.: E2-A01502EN

Date Dec.01.2006

©SHARP Corporation

■ Outline Dimensions

(Unit: mm)

Symbol	Description	Material	Finish
1	Housing	PBT (Color : Black)	-
2	Earth metal	SPCC	Ni plating
3	Contact	Brass	Sn plating
4	Terminal	SPCC	Sn plating
5	Bush	ABS (Color : Orange)	-
6	Holder	PBT (Color : Black)	-
7	Shutter	PBT (Color : Black)	-
8	Lead pin	Cu alloy	SnCu plating

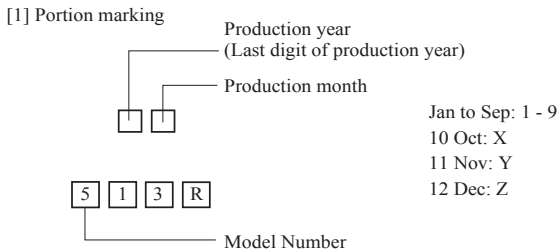
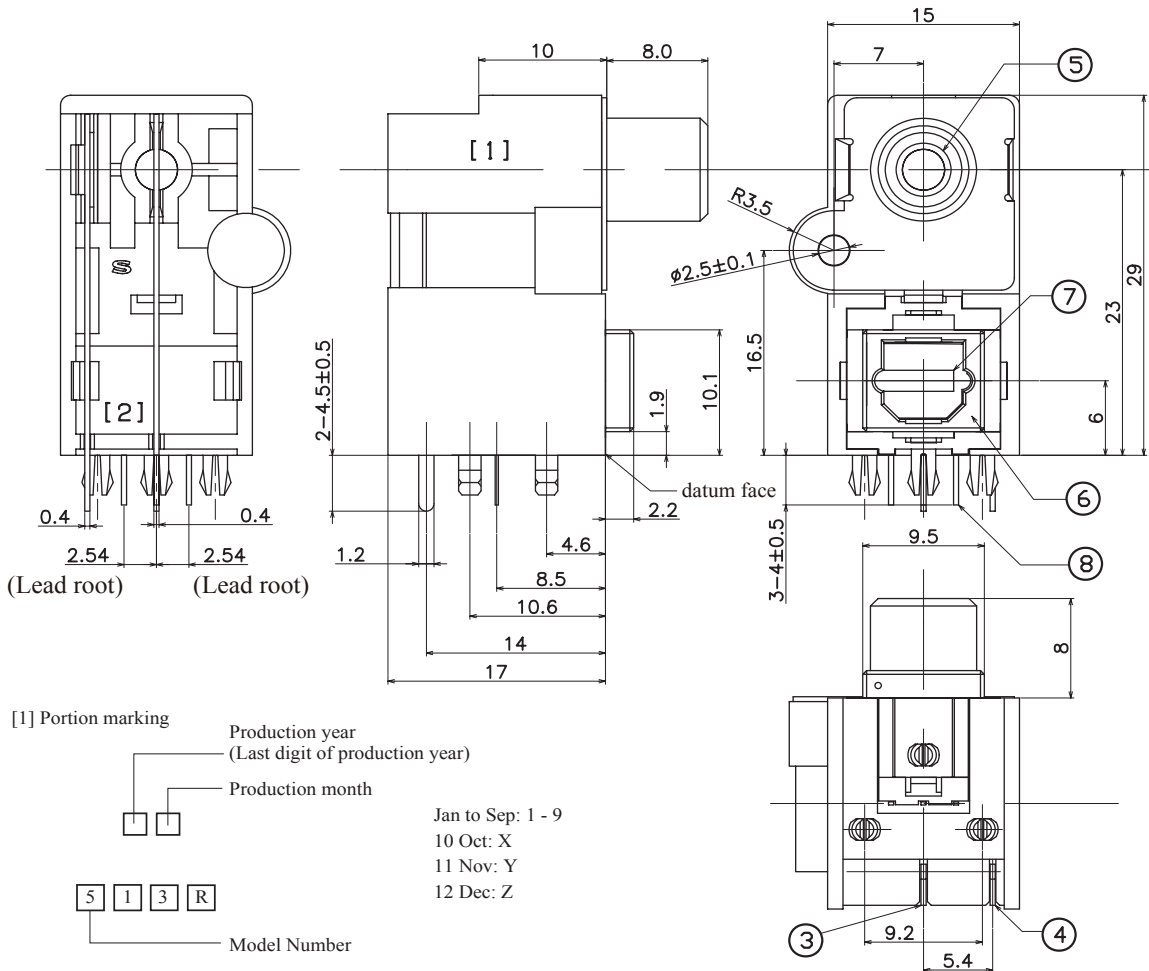
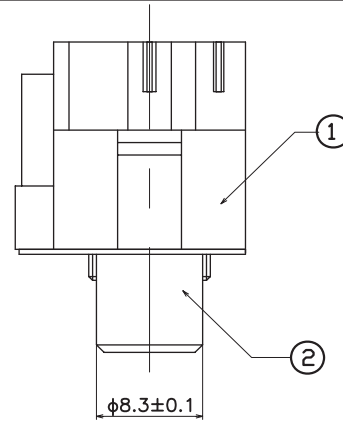

- 1) The pin jack complies with the pin plug JEITA RC-5231.
- 2) The connector joint area complies with the square connector JEITA RC-5720B
- 3) [1] portion : Model No. and date code, [2] portion : material shall be indicated.
(e. g.) > PBT <
- 4) Unspecified tolerance shall be ± 0.3 .
- 5) Dimensions in parenthesis are shown for reference.

Product mass : approx. 8 g

(Unit: mm)

Example of mounting drawing from solder side

Thickness of PCB is 1.6 mm and unspecified tolerance shall be ± 0.1 mm.

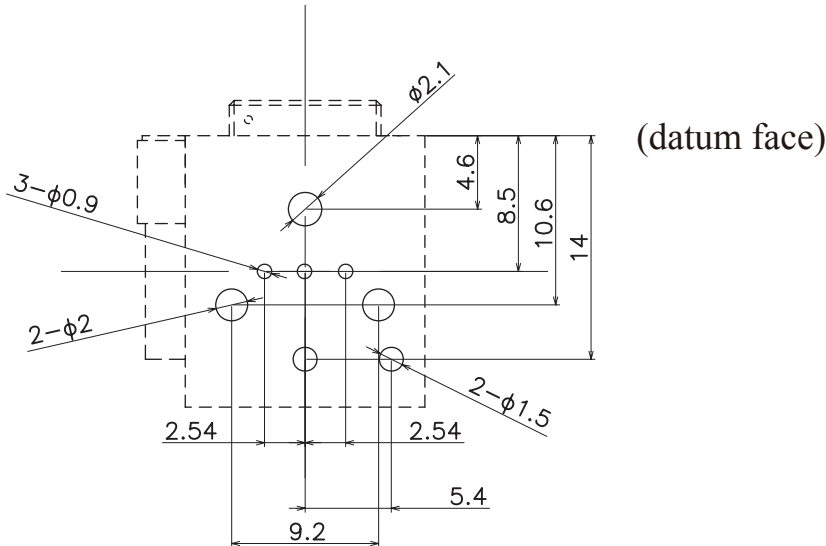

Pin layout

Internal equivalent circuit

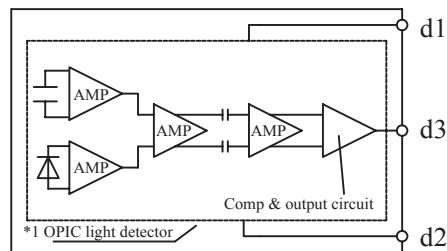
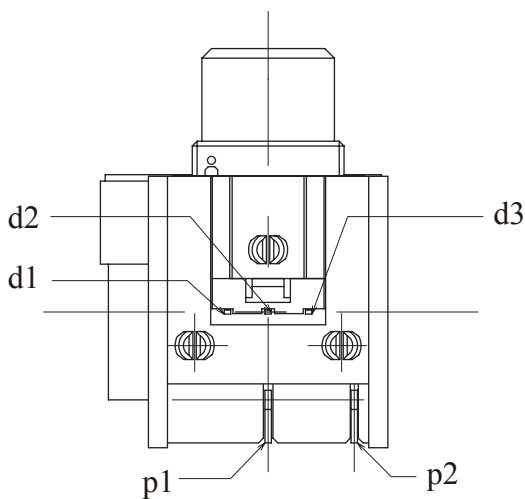

*1 OPIC is a registered trade mark of Sharp (Material : Silicon)

Pin Arrangement

d1 : V_{CC} d2 : GND d3 : V_{out}
 p1 : data p2 : GND

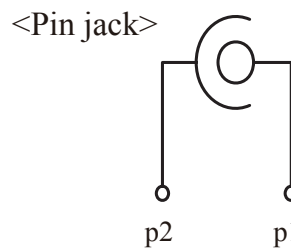

■ Absolute Maximum Ratings (Fiber-optic transmitter)

Parameter	Symbol	Rating	Unit	Remark
Supply voltage	V_{CC}	-0.5 to +7.0	V	
Operating temperature	T_{opr}	-20 to +70	°C	
Storage temperature	T_{stg}	-30 to +70	°C	
Soldering temperature *1	T_{sol}	260	°C	5 s or less/time up to 2 times.
		350	°C	3.5 s or less/time up to 1 time. Soldering by hand at each terminal. *2
Output current	I_{oH}	2	mA	Source current
	I_{oL}	10	mA	Sink current

*1 Solder at a position more than 1.6 mm away from the bottom of housing. Reflow is not available.

*2 Do not contact top of soldering iron to lead terminal directly.

■ Recommended Operating Conditions (Fiber-optic transmitter)

Parameter	Symbol	MIN.	TYP.	MAX.	Unit	Remark
Supply voltage	V_{CC}	4.75	5.0	5.25	V	
Operating transfer rate	T	0.1	-	13.2	Mb/s	Notes (1), (2)
Receiver input optical power level	P_C	-24.0	-	-14.5	dBm	Peak optical output

Notes

(1) This operating transfer rate shall be a specification when NRZ, duty 50 % of continuous "0101..." signal is transferred.

(2) The output (H/L Level) of this product are not fixed constantly when it receives the modulating light (including DC light, no input light) less than 0.1 Mb/s.

■ Electro-optical Characteristics (Fiber-optic transmitter)

($T_a = 25\text{ °C}$, $V_{CC} = 5V$)

Parameter	Symbol	Conditions	MIN.	TYP.	MAX.	Unit
Peak sensitivity wavelength	λ_p		-	700	-	nm
Supply current	I_{CC}	Measurement method refer to Fig. 1	-	16	25	mA
High level output voltage	V_{oH}	Measurement method refer to Fig. 2, 3	2.7	3.5	-	V
Low level output voltage	V_{oL}		-	0.35	0.5	V
Rise time	t_r		-	15	23	ns
Fall time	t_f		-	7	15	ns
L → H delay time	t_{pLH}		-	-	180	ns
H → L delay time	t_{pHL}		-	-	180	ns
Pulse width distortion	Δt_w		-20	-	+20	ns
Jitter	Δt_j		Measurement method refer to Fig. 4, 5, PC = -14.5 dBm	-	1	15
		Measurement method refer to Fig. 4, 5, PC = -24 dBm	-	-	15	ns

■ Absolute Maximum Ratings (Pin jack)

Parameter	Symbol	Rating	Unit	Remark
Total power dissipation	P_{tot}	12	W	DC 12 V, 1 A
Operating temperature	T_{opr}	-20 to +70	°C	
Storage temperature	T_{stg}	-30 to +70	°C	
Soldering temperature *1	T_{sol}	260	°C	5 s or less/time up to 2 times.
		350	°C	3.5 s or less/time up to 1 time. Soldering by hand at each terminal. *2
Isolation voltage	V_{iso}	AC 500 V	-	1 min. rms value

*1 Solder at a position more than 1.6 mm away from the bottom of housing. Reflow is not available.

*2 Do not contact top of soldering iron to lead terminal directly.

■ Measurement Method

Fig. 1 Supply Current

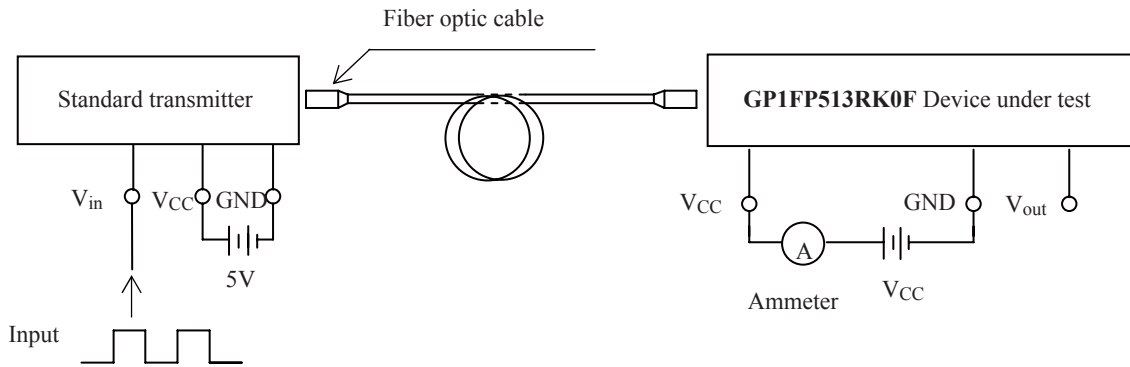

Input conditions		Judgment method
Supply voltage	$V_{cc} = 5.0 \text{ V}$	Measured on an ammeter (DC mean amperage)
Optical fiber coupling light output	$P_c = -14.5 \text{ dBm}$	
Standard transmitter input signal	13.2 Mb/s NRZ, Duty 50 % or 6.6 Mb/s bi-phase mark PRBS signal	

Fig. 2 Output Voltage and Pulse Response

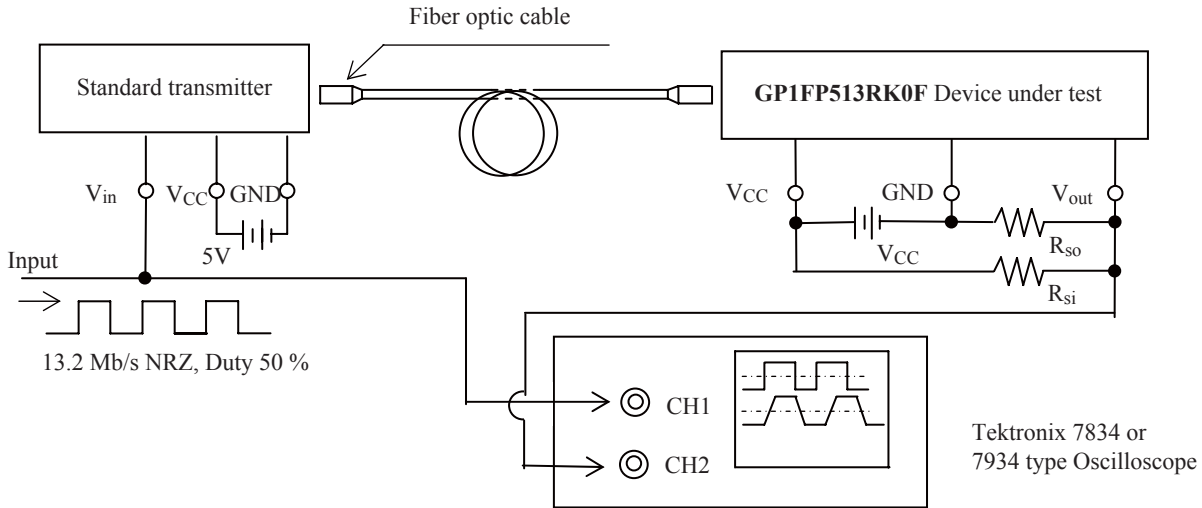
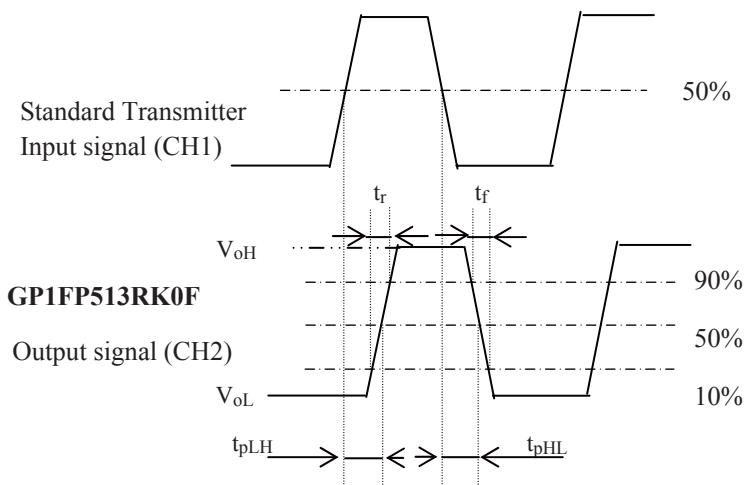

Fig. 3 Input and Output Signal



Notes

- (1) $V_{CC} = 5.0V$ (State of operating)
- (2) The fiber coupling light output set at -14.5 dBm or -24.0 dBm .
- (3) The probe for the oscilloscope must be more than $1 \text{ M}\Omega$ and less than 10 pF .
- (4) R_{si} , R_{so} : Standard load resistor (R_{si} : $3.3 \text{ k}\Omega$, R_{so} : $2.2 \text{ k}\Omega$)
- (5) The output (H/L level) of this device are not fixed constantly when it receives the modulating light (including DC light, no input light) less than 0.1 Mb/s .

Fig. 4 Pulse Response and Jitter

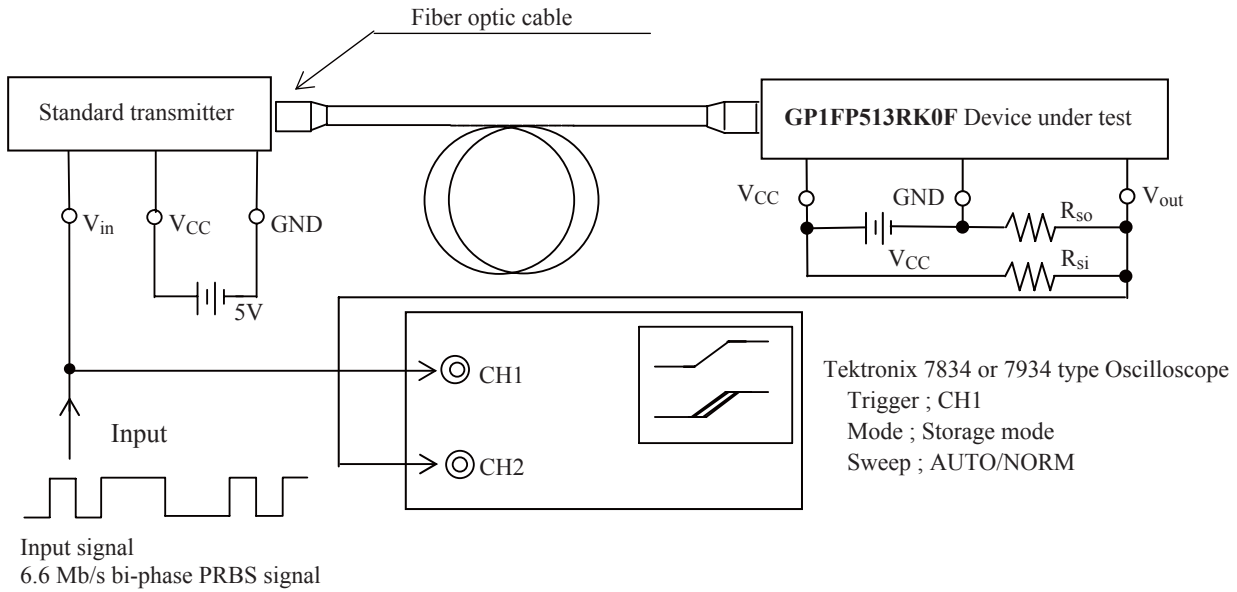
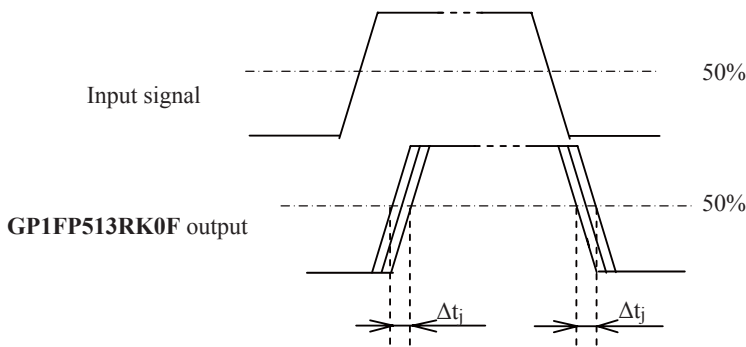

Fig. 5 Input Signal (6.6 Mb/s Bi-phase PRBS Signal)



Notes

- (1) The fiber coupling light output set at -14.5 dBm or -24.0 dBm.
- (2) R_{si}, R_{so}: Standard load resistor (R_{si}: 3.3 k Ω , R_{so}: 2.2 k Ω)
- (3) Set the oscilloscope to the storage mode and write time to 3 seconds.
Do not allow the brightness to be increased too much. The waveform would be distorted.
- (4) V_{CC} = 5.0 V (State of operating)
- (5) The probe for the oscilloscope must be more than 1 M Ω and less than 10 pF.

■Design and Production Notes

(1) Stabilization of power supply line

Please put a by-pass capacitor (0.1 μ F) close to the device at least within 7 mm of the terminal.
Please also put a 4.7 μ F capacitor across the power supply line nearby.

(2) Soldering condition

Solder at the condition within the absolute maximum ratings in this sheet. In case of using flow soldering, please make sure of the conditions of process at the flow equipment. Also, do not use reflow soldering. In case of soldering by hand, do not contact top of soldering iron to lead terminal directly. (Solder at a position more than 1.6 mm away from the base of the lead terminal.)

(3) About getting dirt and dust in the connector coupling portion

In case dirt or dust comes into the connector coupling portion, please use a blower to take it off.
Any rigid rod-like object must not be inserted since into the coupling portion.
The internal device might be damaged, resulting deteriorated characteristics.

(4) Cleaning

Do not immerse for cleaning. The solvent would get into the connector coupling portion resulting deteriorated characteristics. Should it be necessary to remove the flux, please use one of the following solvents only to be applied with a brush.

Solvent : Isopropyl alcohol, Methyl alcohol

(5) Ground during assembling

The human body and the soldering iron must be grounded against the static breakdown of the device during assembling.
Please avoid touching the device terminals as much as possible before assembling.

(6) Assembly of the device

Please fix this device with a screw. In case that this device is not fixed with a screw, stress by detaching connector of internal elements and leads can adversely affect the device's reliability. Excessive torque can deform the package and damage the optics. It can also adversely affect the device's reliability because the device is used under continuous stress. Please confirm the limit of fixing torque to the installation before fixing actually.

Recommended values

Screw : M3.0 \times 8 mm tapping screw

Fixing torque : 0.7 to 0.8 N·m

Force applied by driver etc. : 39 N or less

Note : Please contact and consult with a Sharp sales representative for any questions about above.

(7) Input signal

This product is designed intentionally based upon the signal transmission which is defined by the digital audio interface standard ; CP1201. When a signal out of JEITA standard CP-1201 is inputted to this device, there might be a case that this device can not receive a signal correctly from transmitting unit.

(8) Fixing pin

Since there are other products which has a different fixing pin shape, please make sure to confirm reference mounting drawing for this device.

(9) Damage to connector coupling portion

Please do not stress the connector coupling portion excessively since there might be a case that the shutter can't operate normally.

(10) About getting the flux into connector coupling portion

Please avoid getting a flux into connector coupling portion of this device, because there might be a case that the characteristics deteriorate the shutter can't operate normally.

● **Presence of ODC etc.**

This product shall not contain the following materials.

And they are not used in the production process for this product.

Regulation substances : CFCs, Halon, Carbon tetrachloride, 1.1.1-Trichloroethane (Methylchloroform)

Specific brominated flame retardants such as the PBB and PBDE are not used in this product at all.

This product shall not contain the following materials banned in the RoHS Directive (2002/95/EC).

- Lead, Mercury, Cadmium, Hexavalent chromium, Polybrominated biphenyls (PBB), Polybrominated diphenyl ethers (PBDE).

■ **Packing Specifications**

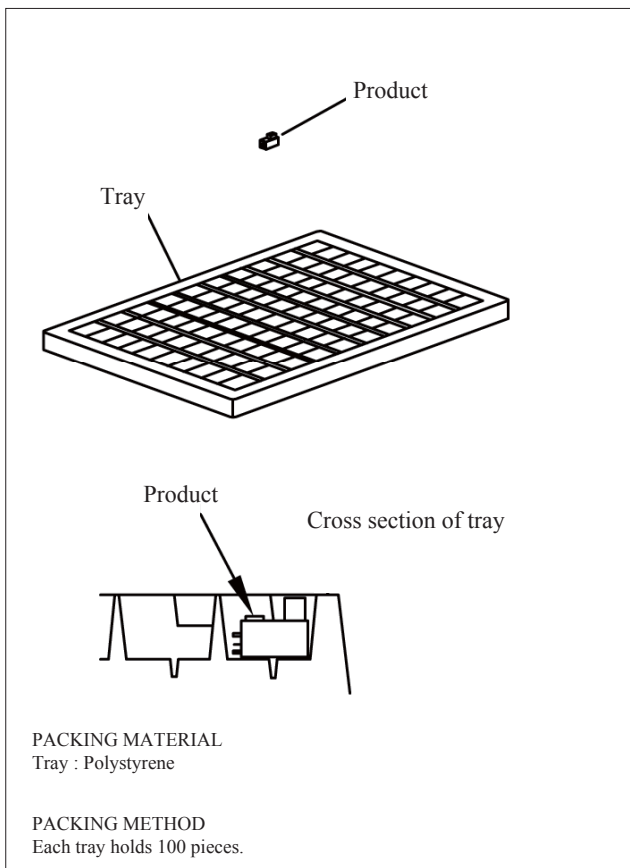

■ Important Notices

- The circuit application examples in this publication are provided to explain representative applications of SHARP devices and are not intended to guarantee any circuit design or license any intellectual property rights. SHARP takes no responsibility for any problems related to any intellectual property right of a third party resulting from the use of SHARP's devices.
- Contact SHARP in order to obtain the latest device specification sheets before using any SHARP device. SHARP reserves the right to make changes in the specifications, characteristics, data, materials, structure, and other contents described herein at any time without notice in order to improve design or reliability. Manufacturing locations are also subject to change without notice.
- Observe the following points when using any devices in this publication. SHARP takes no responsibility for damage caused by improper use of the devices which does not meet the conditions and absolute maximum ratings to be used specified in the relevant specification sheet nor meet the following conditions:
 - (i) The devices in this publication are designed for use in general electronic equipment designs such as:
 - Personal computers
 - Office automation equipment
 - Telecommunication equipment [terminal]
 - Test and measurement equipment
 - Industrial control
 - Audio visual equipment
 - Consumer electronics
 - (ii) Measures such as fail-safe function and redundant design should be taken to ensure reliability and safety when SHARP devices are used for or in connection
 - with equipment that requires higher reliability such as:
 - Transportation control and safety equipment (i.e., aircraft, trains, automobiles, etc.)
 - Traffic signals
 - Gas leakage sensor breakers
 - Alarm equipment
 - Various safety devices, etc.
 - (iii) SHARP devices shall not be used for or in connection with equipment that requires an extremely high level of reliability and safety such as:
 - Space applications
 - Telecommunication equipment [trunk lines]
 - Nuclear power control equipment
 - Medical and other life support equipment (e.g., scuba).
- If the SHARP devices listed in this publication fall within the scope of strategic products described in the Foreign Exchange and Foreign Trade Law of Japan, it is necessary to obtain approval to export such SHARP devices.
- This publication is the proprietary product of SHARP and is copyrighted, with all rights reserved. Under the copyright laws, no part of this publication may be reproduced or transmitted in any form or by any means, electronic or mechanical, for any purpose, in whole or in part, without the express written permission of SHARP. Express written permission is also required before any use of this publication may be made by a third party.
- Contact and consult with a SHARP representative if there are any questions about the contents of this publication.