



Chipsmall Limited consists of a professional team with an average of over 10 year of expertise in the distribution of electronic components. Based in Hongkong, we have already established firm and mutual-benefit business relationships with customers from,Europe,America and south Asia,supplying obsolete and hard-to-find components to meet their specific needs.

With the principle of “Quality Parts,Customers Priority,Honest Operation,and Considerate Service”,our business mainly focus on the distribution of electronic components. Line cards we deal with include Microchip,ALPS,ROHM,Xilinx,Pulse,ON,Everlight and Freescale. Main products comprise IC,Modules,Potentiometer,IC Socket,Relay,Connector.Our parts cover such applications as commercial,industrial, and automotives areas.

We are looking forward to setting up business relationship with you and hope to provide you with the best service and solution. Let us make a better world for our industry!



Contact us

Tel: +86-755-8981 8866 Fax: +86-755-8427 6832

Email & Skype: info@chipsmall.com Web: www.chipsmall.com

Address: A1208, Overseas Decoration Building, #122 Zhenhua RD., Futian, Shenzhen, China



FEATURES

- Trigger point set at factory to 80°
- Digital output
- Range: 20 to 150 cm
- Typical response time: 39 ms
- Typical start up delay: 47 ms
- Average current consumption: 33 mA

DESCRIPTION

The GP2Y0D02YK is a distance measuring sensor with integrated signal processing and digital output.

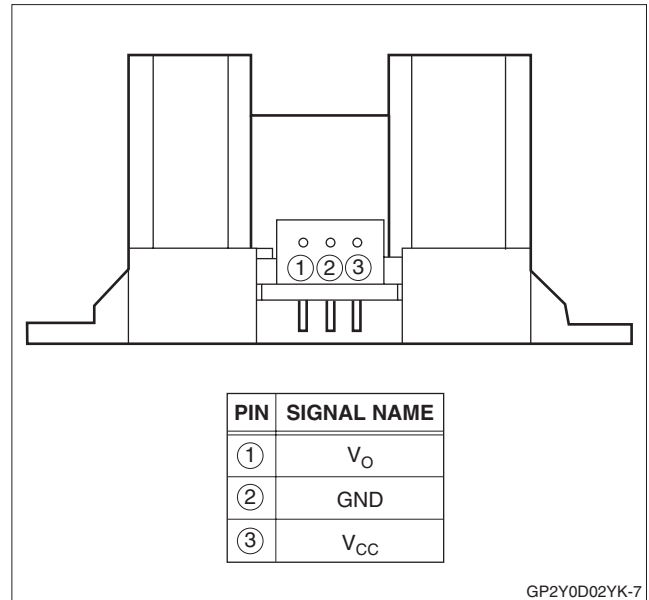

Figure 1. Pinout

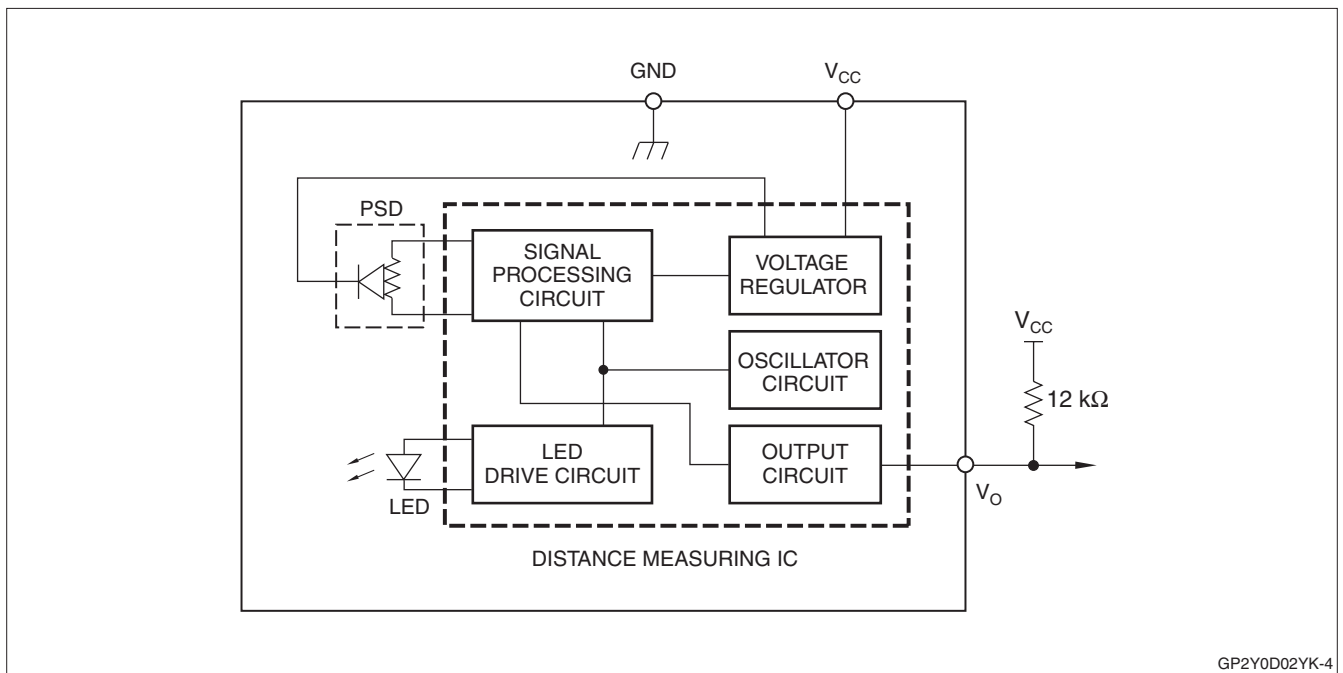

Figure 2. Block Diagram

ELECTRICAL SPECIFICATIONS

Absolute Maximum Ratings

$T_a = 25^\circ\text{C}$, $V_{CC} = 5\text{ VDC}$

PARAMETER	SYMBOL	RATING	UNIT	REMARKS
Supply Voltage	V_{CC}	-0.3 to +7.0	V	
Output Terminal Voltage	V_O	-0.3 to ($V_{CC} + 0.3$)	V	Open collector output
Output Distance Characteristics	T_{opr}	-10 to +60	$^\circ\text{C}$	
Storage Temperature	T_{stg}	-40 to +70	$^\circ\text{C}$	

Operating Supply Voltages

PARAMETER	SYMBOL	RATING	UNIT
Operating Supply Voltage	V_{CC}	4.5 to 5.5	V

Electro-optical Characteristics

PARAMETER	SYMBOL	CONDITIONS	MIN.	TYP.	MAX.	UNIT	NOTES
Measuring Distance Range	ΔL		200	-	1500	mm	1, 3
Output Terminal Voltage	V_{OH}	Output voltage at HIGH level	$V_{CC} - 0.3$	-	-	V	1
	V_{OL}	Output voltage at LOW level	-	-	0.6	V	1
Output Distance Characteristics	V_O		700	800	900	mm	1, 2, 4
Average Supply Current	I_{CC}		-	33	50	mA	

NOTES:

1. Measurements made with Kodak R-27 Gray Card, using the white side, (90% reflectivity).
2. Set at factory for guaranteed measurement at $L = 24\text{ cm} \pm 3\text{ cm}$.
3. Measurement adjustment range.
4. Output switching has hysteresis. The distance specified by V_O is for switching from LOW to HIGH.
5. * L = Distance to reflective object.

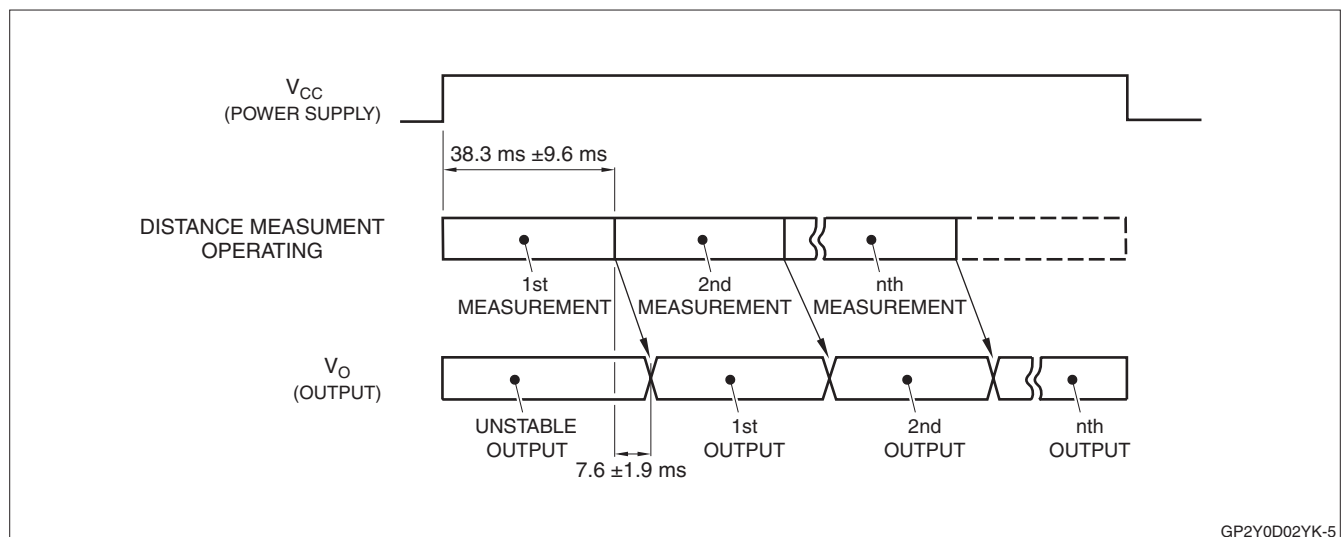

GP2Y0D02YK-5

Figure 3. Timing Diagram

RELIABILITY

The reliability requirements of this device are listed in Table 1.

Table 1. Reliability

TEST ITEMS	TEST CONDITIONS	FAILURE JUDGEMENT CRITERIA	SAMPLES (n), DEFECTIVE (C)
Temperature Cycling	One cycle -40°C (30 min.) to +70°C in 30 minutes, repeated 25 times	Initial $\times 0.8 > V_O$ $V_O > \text{Initial} \times 1.2$	n = 11, C = 0
High Temperature and High Humidity Storage	+40°C, 90% RH, 500h		n = 11, C = 0
High Temperature Storage	+70°C, 500h		n = 11, C = 0
Low Temperature Storage	-40°C, 500h		n = 11, C = 0
Operation Life (High Temperature)	+60°C, $V_{CC} = 5\text{ V}$, 500h		n = 11, C = 0
Mechanical Shock	100 m/s ² , 6.0 ms 3 times/ $\pm X$, $\pm Y$, $\pm Z$ direction		n = 6, C = 0
Variable Frequency Vibration	10-to-55-to-10 Hz in 1 minute Amplitude: 1.5 mm 2h in each X, Y, Z direction		n = 6, C = 0

NOTES:

1. Test conditions are according to Electro-optical Characteristics, shown on page 2.
2. At completion of the test, allow device to remain at nominal room temperature and humidity (non-condensing) for two hours.
3. Confidence level: 90%, Lot Tolerance Percent Defect (LTPD): 20%/40%.

MANUFACTURER'S INSPECTION

Inspection Lot

Inspection shall be carried out per each delivery lot.

Inspection Method

A single sampling plan, normal inspection level II based on ISO 2859 shall be adopted.

Table 2. Quality Level

DEFECT	INSPECTION ITEM/TEST METHOD	AQL (%)
Major Defect	Electro-optical characteristics defect	0.4
Minor Defect	Defect on appearance and dimension (crack, split, chip, scratch, stain)*	1.0

NOTE: *Any one of these that affects the Electro-optical Characteristics shall be considered a defect.

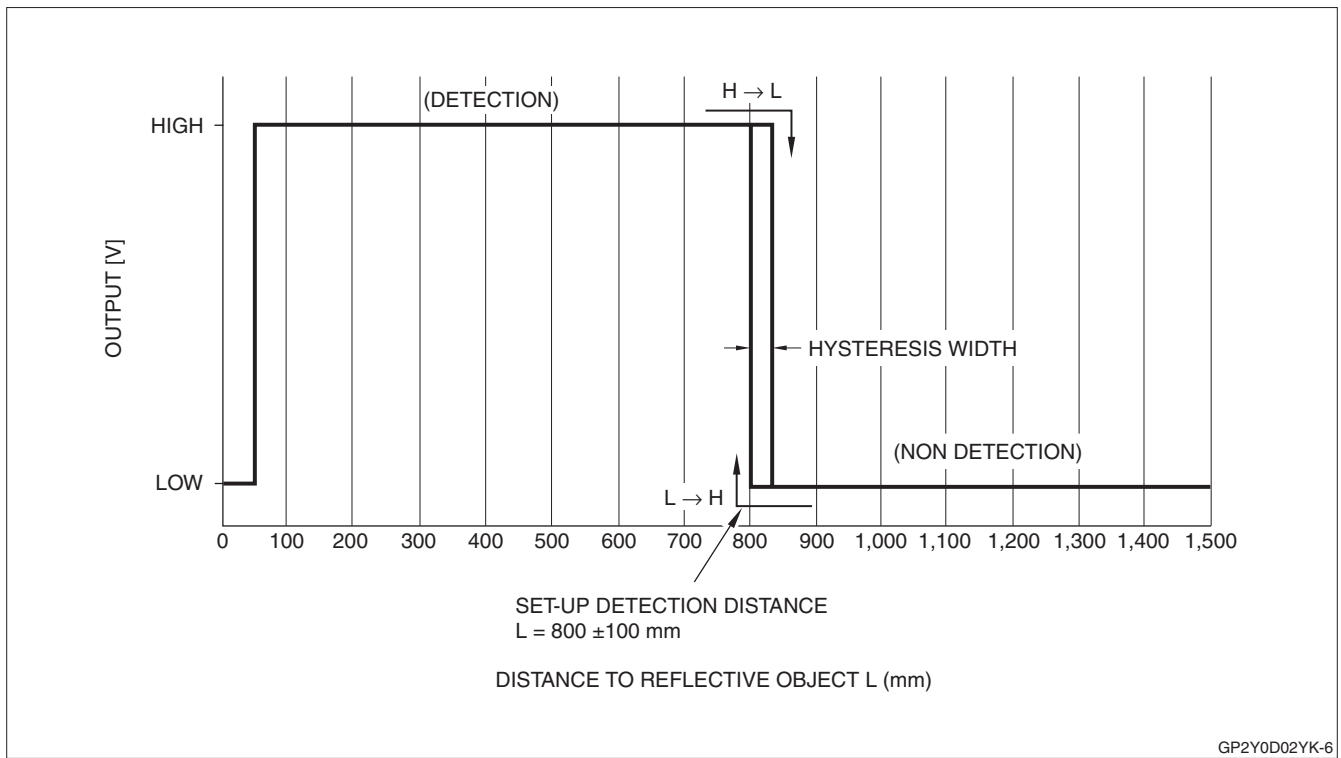
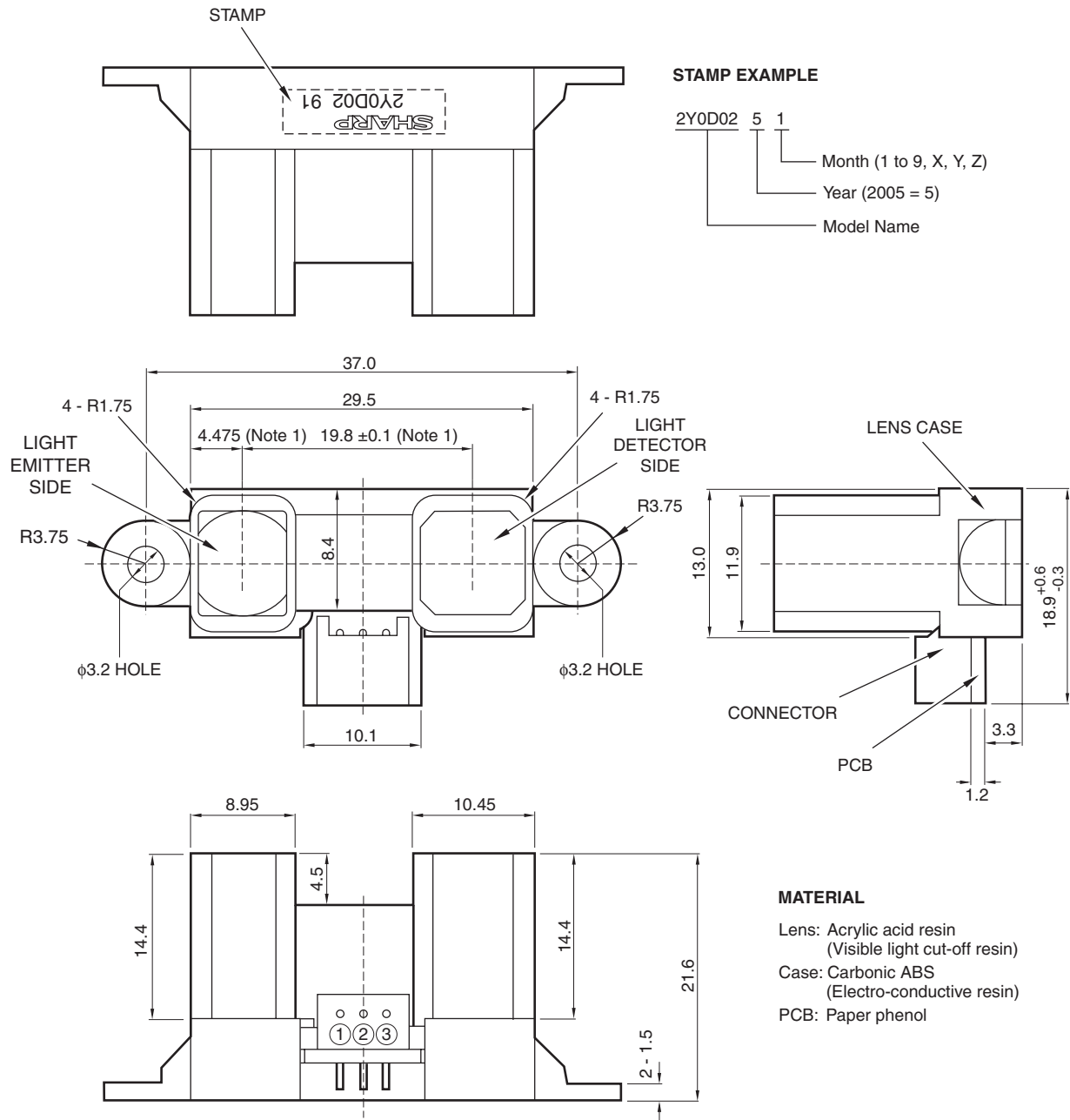

Figure 4. GP2Y0D02YK Example of Output Distance Characteristics

PACKAGE SPECIFICATIONS



STAMP

STAMP EXAMPLE

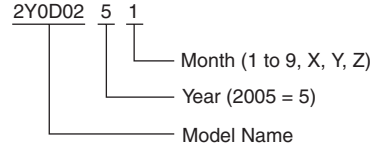

Month (1 to 9, X, Y, Z)
Year (2005 = 5)
Model Name

MATERIAL

Lens: Acrylic acid resin
(Visible light cut-off resin)
Case: Carbonic ABS
(Electro-conductive resin)
PCB: Paper phenol

CONNECTOR SIGNAL

PIN	SIGNAL NAME
①	V _O
②	GND
③	V _{CC}

Connector: J.S.T. Trading Company, LTD
S3B-PH

NOTES:

1. Dimensions reference lens center.
2. Unspecified tolerances are ±0.3 mm.
3. Dimensions are in mm.

PACKING SPECIFICATION

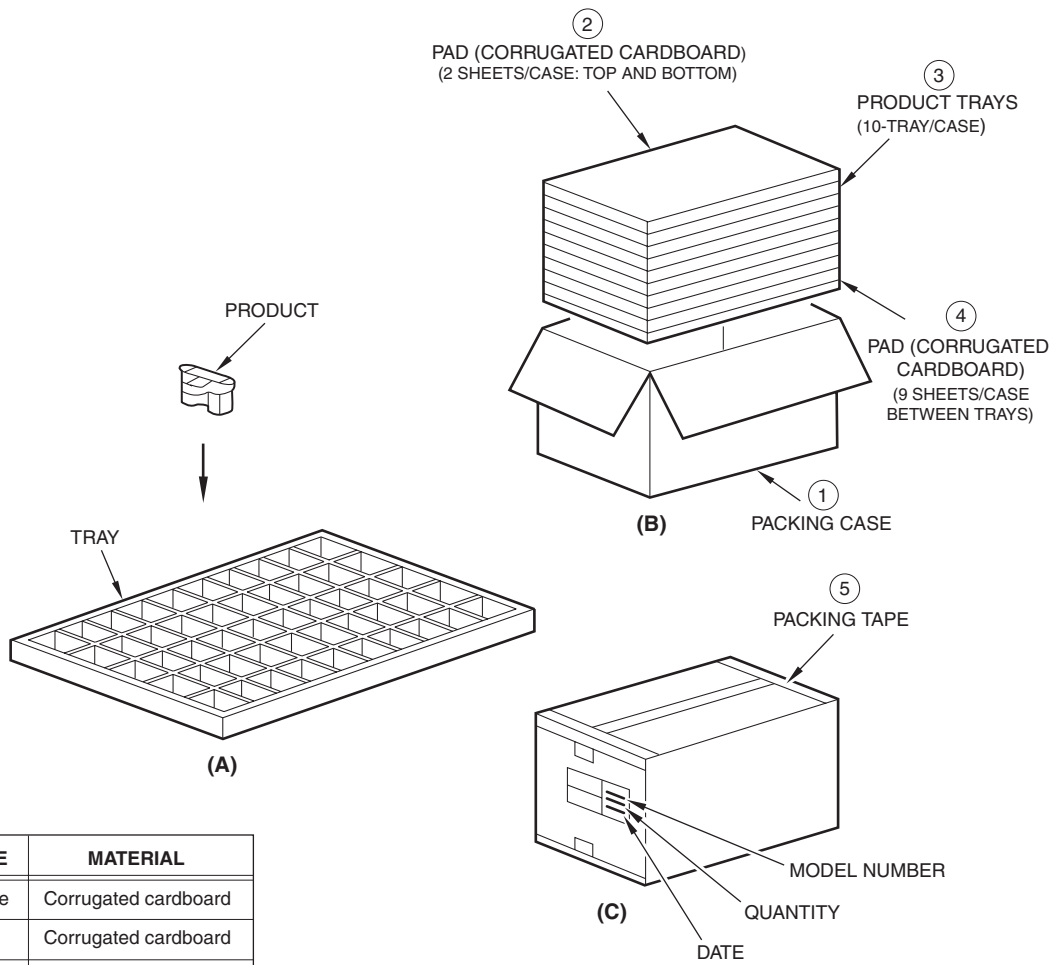

PART NAME	MATERIAL
Packing case	Corrugated cardboard
Pad	Corrugated cardboard
Tray	Polystyrene

PACKING METHOD

1. Each tray holds 50 pieces. Packing methods are shown in (A).
2. Each box holds 10 trays. Pads are added to top and bottom, and between layers, as in (B). top and bottom. Put pads between each tray (9 pads total) see above drawing (B).
3. The box is sealed with craft tape. (C) shows the location of the Model number, Quantity, and Inspection date.
4. Package weight: Approximately 4 kg.

GP2Y0D02YK-9

NOTES

- Keep the sensor lens clean. Dust, water, oil, and other contaminants can deteriorate the characteristics of this device. Applications should be designed to eliminate sources of lens contamination.
- When using a protective cover over the emitter and detector, ensure the cover efficiently transmits light throughout the wavelength range of the LED ($\lambda = 850 \text{ nm} \pm 70 \text{ nm}$). Both sides of the protective cover should be highly polished. Use of a protective cover may decrease the effective distance over which the sensor operates. Ensure that any cover does not negatively affect the operation over the intended application range.
- Objects in proximity to the sensor may cause reflections that can affect the operation of the sensor.
- Sources of high ambient light (the sun or strong artificial light) may affect measurement. For best results, the application should be designed to prevent interference from direct sunlight or artificial light.
- Using the sensor with a mirror can induce measurement errors. Often, changing the incident angle on the mirror can correct this problem.
- If a prominent boundary line exists in the surface being measured, it should be aligned vertically to avoid measurement error. See Figure 5 for further details.
- When measuring the distance to objects in motion, align the sensor so that the motion is in the horizontal direction instead of vertical. Figure 6 illustrates the preferred alignment.
- A 10 μF (or larger) bypass capacitor between V_{CC} and GND near the sensor is recommended.
- To clean the sensor, use a dry cloth. Use of any liquid to clean the device may result in decreased sensitivity or complete failure.
- Excessive mechanical stress can damage the internal sensor or lens.

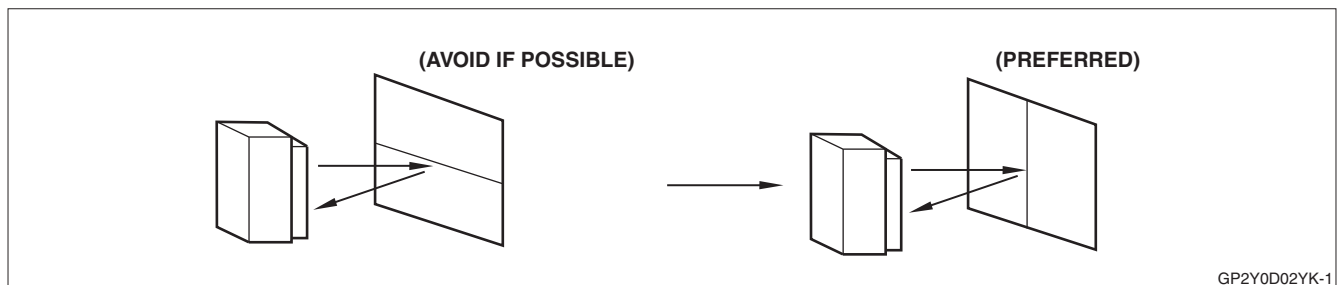

Figure 5. Proper Alignment to Surface Being Measured

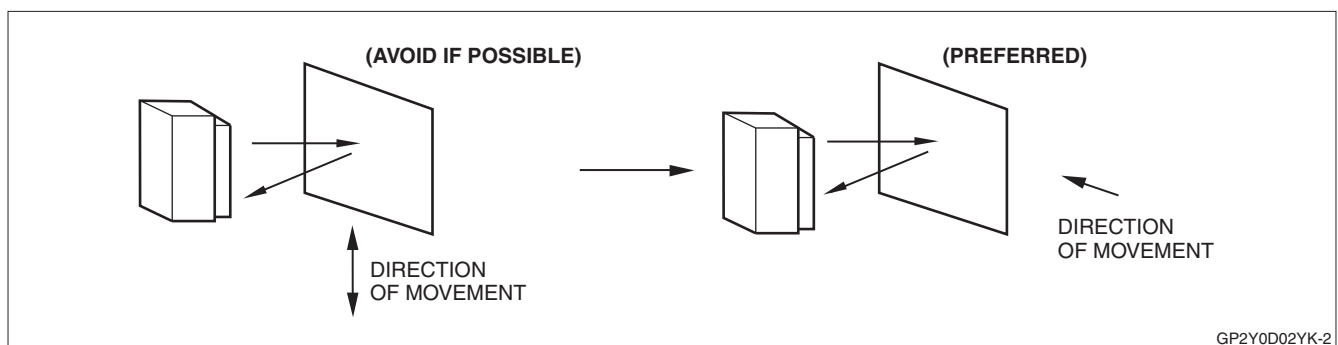

Figure 6. Proper Alignment to Moving Surfaces

NOTICE

The circuit application examples in this publication are provided to explain representative applications of SHARP devices and are not intended to guarantee any circuit design or license any intellectual property right. SHARP takes no responsibility for any problems related to any intellectual property right of a third party resulting from the use of SHARP devices.

SHARP reserves the right to make changes in the specifications, characteristics, data, materials, structures and other contents described herein at any time without notice in order to improve design or reliability.

Contact SHARP in order to obtain the latest device specification sheets before using any SHARP device. Manufacturing locations are also subject to change without notice.

In the absence of confirmation by device specification sheets, SHARP takes no responsibility for any defects that occur in equipment using any SHARP devices shown in catalogs, data books, etc.

The devices listed in this publication are designed for standard applications for use in general electronic equipment. SHARP's devices shall not be used for or in connection with equipment that requires an extremely high level of reliability, such as military and aerospace applications, telecommunication equipment (trunk lines), nuclear power control equipment and medical or other life support equipment (e.g. Scuba). SHARP takes no responsibility for damage caused by improper use of device, which does not meet the conditions for use specified in the relevant specification sheet.

If the SHARP devices listed in the publication fall within the scope of strategic products described in the Foreign Exchange and Foreign Trade Law of Japan, it is necessary to obtain approval to export such SHARP devices.

This publication is the proprietary product of SHARP and is copyrighted, with all rights reserved. Under the copyright laws, no part of this publication may be reproduced or transmitted in any form or by any means, electronic or mechanical for any purpose, in whole or in part, without the express written permission of SHARP. Express written permission is also required before any use of this publication may be made by a third party.

Contact and consult with a SHARP representative if there are any questions about the contents of this publication.

SHARP

SHARP CORPORATION
SALES & MARKETING GROUP
ELECTRONIC COMPONENTS & DEVICES
22-22 NAGAIKE-CHO, ABENO-KU, OSAKA 545-8522, JAPAN
PHONE: (81) 6-6621-1221
FAX: (81) 6117-725300, 6117-725301, 6117-725302
<http://sharp-world.com/products/device>

Specifications are subject to change without notice.

Countries and Areas

U.S.A.

SHARP MICROELECTRONICS
OF THE AMERICAS

North American Head Office
5700 North West Pacific Rim Boulevard
Camas, Washington 98607 USA
PHONE: (1)360-834-2500
FAX: (1)360-834-8903
<http://www.sharpsma.com>

Western Area

1980 Zanker Road, San Jose, CA 95112
PHONE: (1)408-436-4900
FAX: (1)408-436-0924

5901 Bolsa Ave.
Huntington Beach, CA 92647-2053
PHONE: (1)714-903-4600
FAX: (1)714-903-0295

6390 Greenwich Drive, Suite 175
San Diego, CA 92122
PHONE: (1)858-597-0982
FAX: (1)858-597-8701

Central Area

85 W. Algonquin Road, Suite 280
Arlington Heights, IL 60005
PHONE: (1)847-258-2750
FAX: (1)847-439-2479

6303 Commerce Drive, Suite 175 Irving, TX 75063
PHONE: (1)972-582-1710
FAX: (1)972-580-7537

8911 Capitol of Texas Hwy. Suite 3130
Austin, TX 78759
PHONE: (1)512-349-7262
FAX: (1)512-349-7002

20333 State Hwy. 249, Suite 200 Houston, TX 77070
PHONE: (1)281-378-1520
FAX: (1)281-378-1521

W129 S 9647 Tony Lema Lane Muskego, WI 53150
PHONE: (1)414-529-9568
FAX: (1)414-529-9569

3001 West Big Beaver Road, Suite 722
Troy, MI 48064
PHONE: (1)248-458-1527
FAX: (1)248-458-6255

Eastern Area

1070 N. Kimbles Road, Yardley, PA 19067
PHONE: (1)215-321-5530
FAX: (1)215-321-5534

200 Wheeler Rd., Burlington, MA 01803
PHONE: (1)781-270-7979; (1)781-229-5100
FAX: (1)781-229-9117

8000 Regency Parkway, Suite 280 Cary, NC 27511
PHONE: (1)919-460-0695
FAX: (1)919-460-0795

2321 Sidney St. Pittsburgh, PA 15203
PHONE: (1)412-381-1191
FAX: (1)412-381-1192

4875 North Federal Highway, Third Floor
Ft. Lauderdale, FL 33318
PHONE: (1)954-267-8883
FAX: (1)954-267-0254

EUROPE

SHARP MICROELECTRONICS EUROPE
A division of Sharp Electronics (Europe) GmbH

Head Office
Sonninstrasse 3, 20097, Hamburg, Germany
PHONE: (49)180-5073507
FAX: (49)40-2376-2232
<http://www.sharpsme.com/>

Germany

SME München Office
Fuerstenriederstrasse 5, 80687 München, Germany
PHONE: (49)89-5468420
FAX: (49)89-54 684250

France

SME Paris Office
1 Rue Raoul Follereau Bussy Saint Georges
77608 Marne la Vallee Cedex 3
PHONE: (33)1 6476 22 22
FAX: (33)1 6476 22 23

Italy

SME Milano Office
Centro Direzionale Colleoni
Palazzo Taurus Ingresso 2
20041 Agrate Brianza, Milano, Italy
PHONE: (39)39-68 99 946
FAX: (39)39-68 99 948

U.K .

SME London Office
Centennial Court, Easthampstead Road,
Bracknell, Berkshire R G12 1YQ, United Kingdom
PHONE: (44)1344-86 99 22
FAX: (44)1344-36 09 03

Ireland

SME Dublin Office
First Floor, Block 1, St. Johns Court, Santry,
Dublin 9, Ireland
PHONE: (353)1-842 87 05
FAX: (353)1-842 84 55

ASIA

SHARP ELECTRONICS (SHANGHAI) CO., LTD.
Microelectronics Sales & Marketing Division
16F, King Tower, 28 Xin Jin Qiao Road,
Pudong DIST, Shanghai 201206 P.R . China
PHONE: (86)21-5854-7710/21-5834-6056
FAX: (86)21-5854-4340/21-5834-6057

Registered Address

No. 11, De Bao Road, Xin Development BLDG
46 Wai Gao Qiao Free Trade Zone, Shanghai
200131, P.R . China

Beijing Office

Room 1062, Beijing Jing An Center No. 8 East
Bei San Huan Road, Chao Yang DIST, Beijing
100028 P.R . China
PHONE: (86) 10-6466-7543/10-6466-6561
FAX: (86) 10-6468-8920
<http://sharp-world.com/products/devicechina/index.html>

SHARP-ROXY (HONG KONG) LTD.

Device Sales Division, 17/F, Admiralty Centre,
Tower 1, 18 Harcourt Road, Hong Kong
PHONE: (852)28229311
FAX: (852)28660779
<http://www.sharp.com.hk>

Shenzhen Representative Office

Room 13B1, Tower C, Electronics Science &
Technology Building, Shen Nan Zhong Road,
Shenzhen, P.R . China
PHONE: (86)755-83273731
FAX: (86)755-83273735

SHARP ELECTRONIC COMPONENTS

(TAIWAN) CORPORATION
8F-A, No. 16, Sec. 4, Nanking E. R d., Taipei, Taiwan
PHONE: (886)2-2577-7341
FAX: (886)2-2577-7326/2-2577-7328

SHARP ELECTRONICS (SINGAPORE) PTE ., LTD.

396 Alexandra Road #07-00
BP Tower Singapore 119954
PHONE: (65) 62713566
FAX: (65) 62713855
<http://www.sesi-sharp.com>

SHARP MICROELECTRONICS

TECHNOLOGY (M) SDN BHD.
Suite E 408, 4th Floor, East Tower,
Wisma Consplant 1, No. 2 J In. SS 16/4,
Subng Jaya, 47500, Selangor Darul Ehsan, Malaysia
PHONE: (60) 3-5637-8964
FAX: (60) 3-5638-4029

SHARP ELECTRONIC COMPONENTS

(KOREA) CORPORATION
RM 501 iLsin B/D. 541, Dohwa-dong,
Mapo-ku, Seoul, Korea, 121-701
PHONE: (82)2-711-5813 ~ 8
FAX: (82)2-711-5819

Distributed By