



Chipsmall Limited consists of a professional team with an average of over 10 year of expertise in the distribution of electronic components. Based in Hongkong, we have already established firm and mutual-benefit business relationships with customers from,Europe,America and south Asia,supplying obsolete and hard-to-find components to meet their specific needs.

With the principle of “Quality Parts,Customers Priority,Honest Operation,and Considerate Service”,our business mainly focus on the distribution of electronic components. Line cards we deal with include Microchip,ALPS,ROHM,Xilinx,Pulse,ON,Everlight and Freescale. Main products comprise IC,Modules,Potentiometer,IC Socket,Relay,Connector.Our parts cover such applications as commercial,industrial, and automotives areas.

We are looking forward to setting up business relationship with you and hope to provide you with the best service and solution. Let us make a better world for our industry!



Contact us

Tel: +86-755-8981 8866 Fax: +86-755-8427 6832

Email & Skype: info@chipsmall.com Web: www.chipsmall.com

Address: A1208, Overseas Decoration Building, #122 Zhenhua RD., Futian, Shenzhen, China



THIS COPY IS PROVIDED ON A RESTRICTED BASIS AND IS NOT TO BE USED IN ANY WAY DETRIMENTAL TO THE INTERESTS OF PANDUIT CORP.

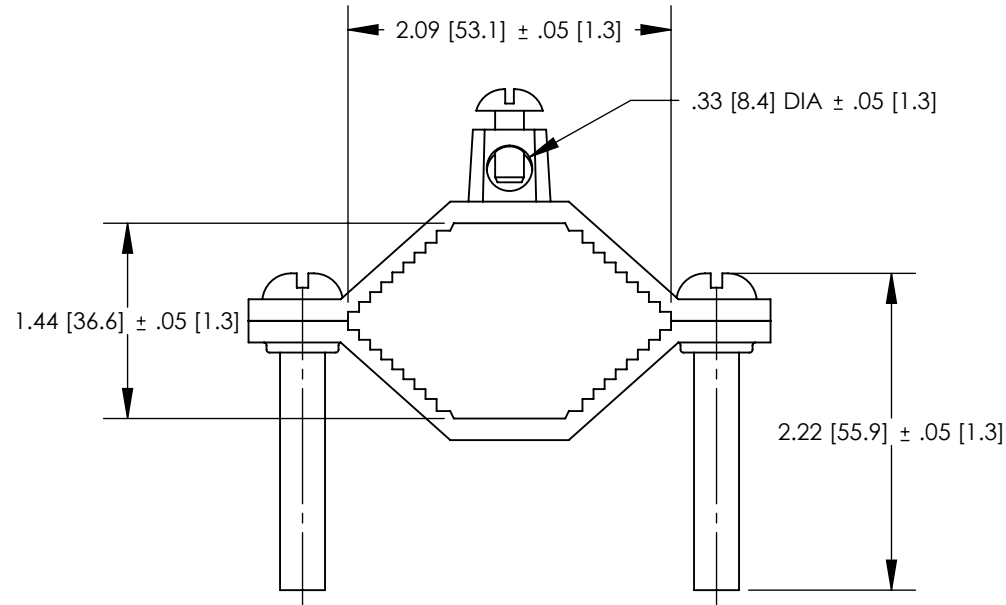
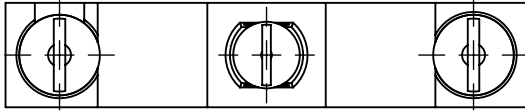

NOTES:

- MATERIAL:
BODY - BRONZE (GUN METAL)
SCREW - PHOS. BRONZE (GPC2-2D)
STEEL, ZINC PLATED (GPC2-2)
- PARTS ARE cULus LISTED TO UL467 AS GROUNDING & BONDING EQUIPMENT.
- RATED FOR DIRECT BURIAL (GPC2-2D ONLY)
- SEE WWW.PANDUIT.COM FOR PART NUMBER SUFFIX DESIGNATION FOR PACKAGE SIZE.



GPC2-2D ONLY

PART NUMBER	DESCRIPTION	WATER PIPE	GROUNDING WIRE
GPC2-2	GROUND CLAMP BARE WIRE	1-1/4" - 2"	10 - 2 STR
GPC2-2D	GROUND CLAMP BARE WIRE DIRECT BURIAL	1-1/4" - 2"	10 - 2 STR

00	7/12	JHNU	SRBI	RGB	DRAWING RELEASED	10J018AJ-JC
REV	DATE	BY	CHK	APR	DESCRIPTION	ECN

TITLE BRONZE GROUND PIPE CLAMP - 1-1/4"-2" CUSTOMER DRAWING	
ITEM REVISION NAME 10J018AJ/00	PANDUIT TM
DATASET FILE NAME 10J018AJ-JC/00.SLDDRW	
UNLESS OTHERWISE SPECIFIED, DIMENSIONAL TOLERANCES ARE: IN [mm] .X ± .XXX ± .XX ± ANGLES ±	
THIRD ANGLE PROJECTION	
DRAWN BY JHNU	DATE 7/12
CHK SRBI	SCALE N/A
DRAWING NUMBER 10J018AJ-JC	
SHEET 1 OF 1	
SIZE A	