



Chipsmall Limited consists of a professional team with an average of over 10 year of expertise in the distribution of electronic components. Based in Hongkong, we have already established firm and mutual-benefit business relationships with customers from,Europe,America and south Asia,supplying obsolete and hard-to-find components to meet their specific needs.

With the principle of “Quality Parts,Customers Priority,Honest Operation,and Considerate Service”,our business mainly focus on the distribution of electronic components. Line cards we deal with include Microchip,ALPS,ROHM,Xilinx,Pulse,ON,Everlight and Freescale. Main products comprise IC,Modules,Potentiometer,IC Socket,Relay,Connector.Our parts cover such applications as commercial,industrial, and automotives areas.

We are looking forward to setting up business relationship with you and hope to provide you with the best service and solution. Let us make a better world for our industry!



Contact us

Tel: +86-755-8981 8866 Fax: +86-755-8427 6832

Email & Skype: info@chipsmall.com Web: www.chipsmall.com

Address: A1208, Overseas Decoration Building, #122 Zhenhua RD., Futian, Shenzhen, China



HD/SD-SDI Serializer with Complete SMPTE Audio & Video Support

Key Features

- Operation at 1.485Gb/s, 1.485/1.001Gb/s, and 270Mb/s
- Supports SMPTE ST 292, SMPTE ST 259-C, and DVB-ASI
- Integrated Cable Driver
- Integrated, low-noise VCO
- Integrated Narrow-Bandwidth PLL
- Integrated Audio Embedder for up to 8 channels of 48kHz audio
- Ancillary data insertion
- Parallel data bus selectable as either 20-bit or 10-bit
- SMPTE video processing including TRS calculation and insertion, line number calculation and insertion, line based CRC calculation and insertion, illegal code re-mapping, SMPTE ST 352 payload identifier generation and insertion
- GSPI host interface
- +1.2V digital core power supply, +1.2V and +3.3V analog power supplies, and selectable +1.8V or +3.3V I/O power supply
- -20°C to +85°C operating temperature range
- Low power operation (typically at 350mW, including Cable Driver)
- Small 11mm x 11mm 100-ball BGA package
- Pb-free and RoHS compliant

Applications

Application: 1080p 30 Camera/Camcorder

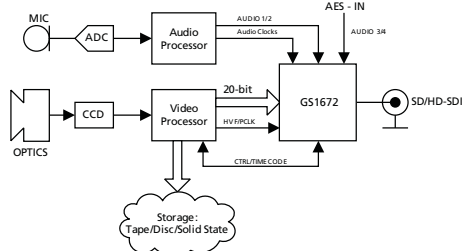

Application: Multi-format Audio Embedded Module

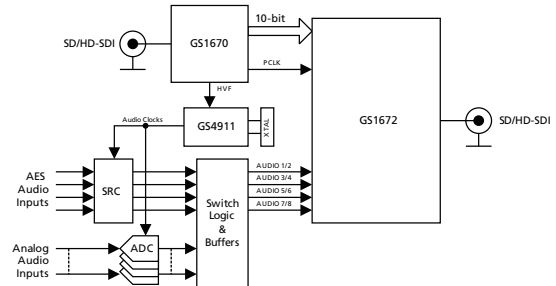

Application: Multi-format Digital VTR/Video Server

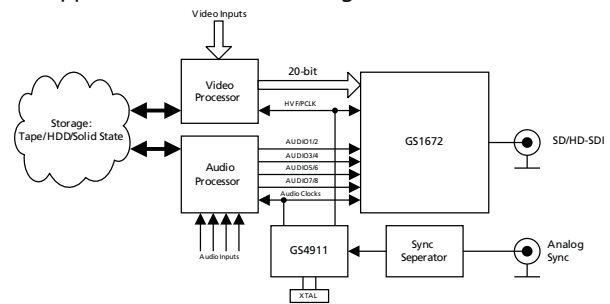

Application: Multi-format Presentation Switcher (Output Stage)

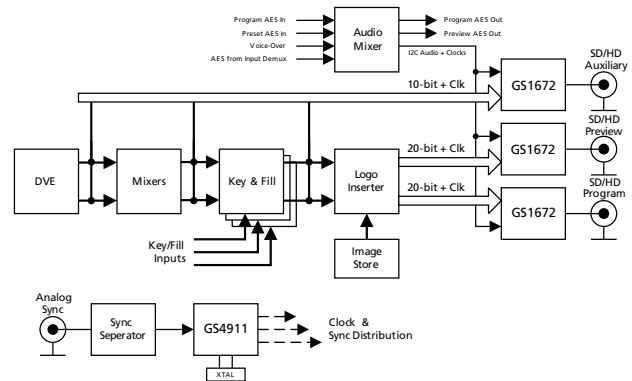

Application: HD-SDI Test Signal Generator

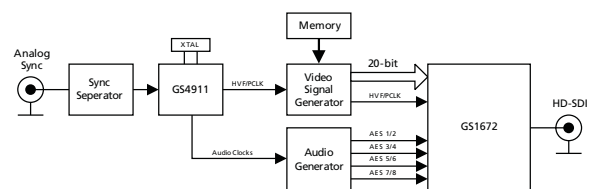

Description

The GS1672 is a complete SDI Transmitter, generating a SMPTE ST 292, SMPTE ST 259-C, or DVB-ASI compliant serial digital output signal.

The integrated narrow BW PLL allows the device to accept parallel clocks with high input jitter, and still provide a SMPTE compliant serial digital output.

The device can operate in four basic user selectable modes: SMPTE mode, DVB-ASI mode, Data-Through mode, or Standby mode.

In DVB-ASI mode, the device will perform 8b/10b encoding prior to transmission.

In Data-Through mode, all SMPTE and DVB-ASI processing is disabled. The device can be used as a simple parallel to serial converter.

The device can also operate in a lower power Standby mode. In this mode, no signal is generated at the output.

The GS1672 integrates a fully SMPTE-compliant Cable Driver for SMPTE ST 259-C and SMPTE ST 292 interfaces. It features automatic dual slew-rate selection, depending on HD or SD operational requirements.

In accordance with SMPTE ST 272 and SMPTE ST 299, up to eight channels (two audio groups) of serial digital audio may be embedded into the video data stream. The input audio signal formats supported by the device include AES/EBU, I²C and serial audio. 16, 20, and 24-bit audio formats are supported at 48kHz synchronous for SD modes and 48kHz synchronous or asynchronous in HD modes.

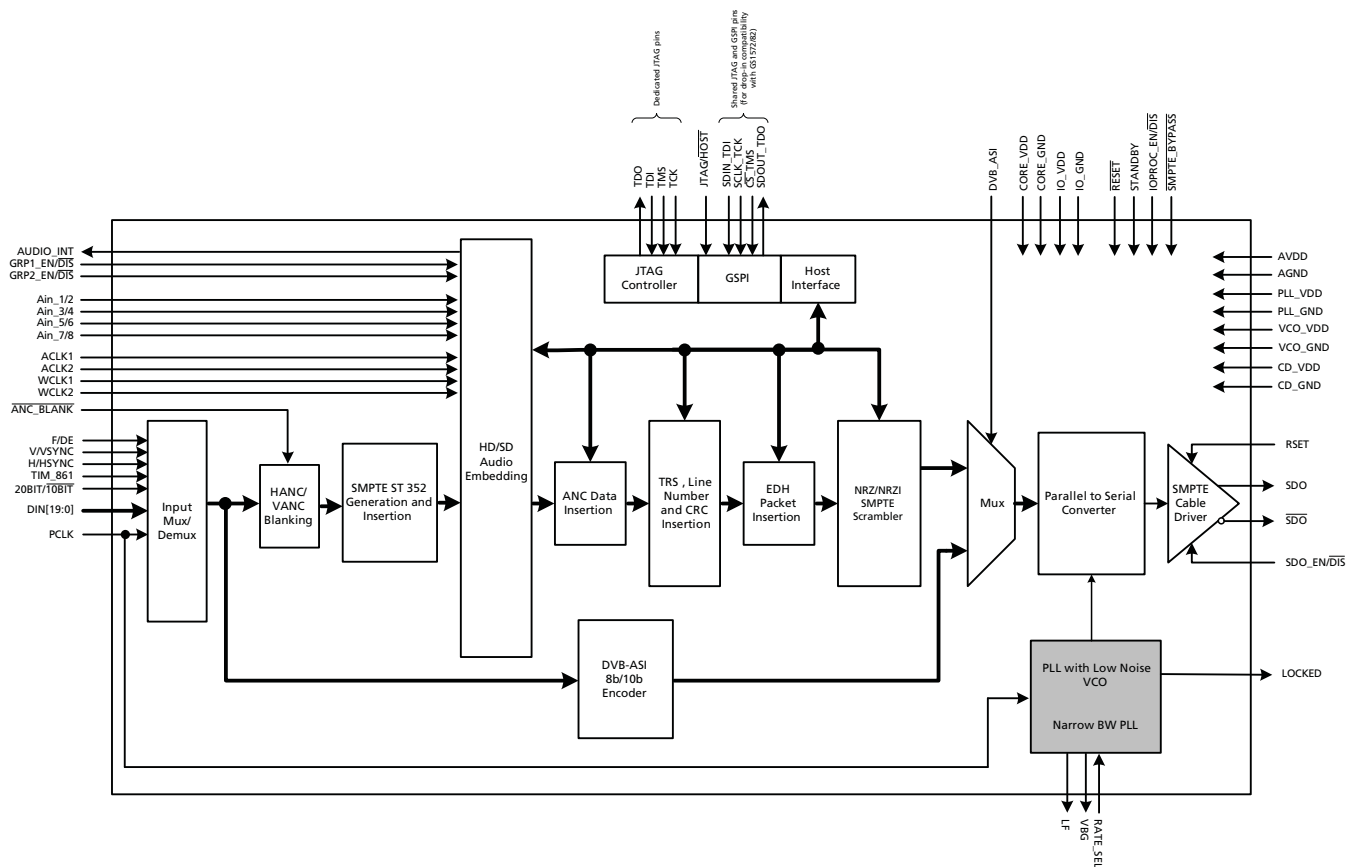

GS1672 Functional Block Diagram

Revision History

Version	ECO	PCN	Date	Changes and/or Modifications
8	025654	–	August 2015	Updated Table 2-4: AC Electrical Characteristics .
7	014806	–	September 2013	Updates throughout the document.
6	156652	–	July 2011	Correction to the Typical Application Circuit .
5	155608	–	January 2011	Clarified the function of the ACS_REGEN bit in Section 4.7.10 Audio Channel Status .
4	155080	56060	October 2010	Revised power rating in standby mode. Documented CSUM behaviour in Section 4.8 , Section 4.9.3 and Video Core Configuration and Status Registers .
3	153743	–	March 2010	Correction to ANC Data Insertion addresses 040h - 13Fh in Table 4-34: Video Core Configuration and Status Registers . Changed Reset Pulse width from 10ms to 1ms in Table 2-4: AC Electrical Characteristics and 4.18 Device Reset . Changed Pin E4 to IO_GND.
2	153550	–	January 2010	Removed VCO Supply Voltage from Table 2-2: Recommended Operating Conditions , and revised VCO_VDD Pin Description in Table 1-1: Pin Descriptions .
1	153472	–	January 2010	Converted to Data Sheet.
0	153211	–	November 2009	Converted to Preliminary Data Sheet. Changed pin E4 to RSV in Pin Assignment , Pin Descriptions and Typical Application Circuit .
A	152842	–	October 2009	New Document.

Contents

Key Features.....	1
Applications	1
Description	2
Revision History	3
1. Pin Out.....	9
1.1 Pin Assignment	9
1.2 Pin Descriptions	10
2. Electrical Characteristics.....	19
2.1 Absolute Maximum Ratings	19
2.2 Recommended Operating Conditions	19
2.3 DC Electrical Characteristics	20
2.4 AC Electrical Characteristics	21
3. Input/Output Circuits.....	24
4. Detailed Description.....	26
4.1 Functional Overview	26
4.2 Parallel Data Inputs	26
4.2.1 Parallel Input in SMPTE Mode.....	28
4.2.2 Parallel Input in DVB-ASI Mode.....	28
4.2.3 Parallel Input in Data-Through Mode	29
4.2.4 Parallel Input Clock (PCLK).....	29
4.3 SMPTE Mode	30
4.3.1 H:V:F Timing	30
4.3.2 CEA 861 Timing.....	31
4.4 DVB-ASI Mode	38
4.5 Data-Through Mode	38
4.6 Standby Mode	38
4.7 Audio Embedding	39
4.7.1 Serial Audio Data Inputs	39
4.7.2 Serial Audio Data Format Support	41
4.7.3 HD Mode.....	42
4.7.4 SD Mode	42
4.7.5 Audio Embedding Operating Modes.....	43
4.7.6 Audio Packet Detection	43
4.7.7 Audio Packet Deletion.....	44
4.7.8 Audio Packet Detection and Deletion	44
4.7.9 Audio Mute (Default Off)	45
4.7.10 Audio Channel Status.....	45
4.7.11 Audio Crosspoint	46
4.7.12 Audio Word Clock.....	47
4.7.13 Channel & Group Activation	47
4.7.14 Audio FIFO - SD.....	48
4.7.15 Audio FIFO - HD.....	49
4.7.16 Five-frame Sequence Detection - SD.....	49

4.7.17	Frame Sequence Detection - HD	52
4.7.18	ECC Error Detection and Correction	53
4.7.19	Audio Control Packet Insertion - SD	53
4.7.20	Audio Control Packet Insertion - HD	54
4.7.21	Audio Data Packet Insertion	55
4.7.22	Audio Interrupt Control	56
4.8	ANC Data Insertion	56
4.8.1	ANC Insertion Operating Modes	57
4.8.2	HD ANC Insertion	58
4.8.3	SD ANC Insertion	59
4.9	Additional Processing Functions	60
4.9.1	Video Format Detection	60
4.9.2	ANC Data Blanking	62
4.9.3	ANC Data Checksum Calculation and Insertion	63
4.9.4	TRS Generation and Insertion	63
4.9.5	HD Line Number Calculation and Insertion	63
4.9.6	Illegal Code Re-Mapping	64
4.9.7	SMPTE ST 352 Payload Identifier Packet Insertion	64
4.9.8	Line Based CRC Generation and Insertion (HD)	64
4.9.9	EDH Generation and Insertion	65
4.9.10	HD HANC Space Considerations when Embedding Audio	66
4.9.11	Processing Feature Disable	67
4.10	ST 352 Data Extraction	68
4.11	Serial Clock PLL	69
4.11.1	PLL Bandwidth	69
4.11.2	Lock Detect	70
4.12	Serial Digital Output	71
4.12.1	Output Signal Interface Levels	72
4.12.2	Overshoot/Undershoot	72
4.12.3	Slew Rate Selection	73
4.12.4	Serial Digital Output Mute	73
4.13	GSPI Host Interface	73
4.13.1	Command Word Description	74
4.13.2	Data Read or Write Access	75
4.13.3	GSPI Timing	75
4.14	Host Interface Register Maps	78
4.14.1	Video Core Registers	78
4.14.2	SD Audio Core	88
4.14.3	HD Audio Core Registers	100
4.15	JTAG ID Codeword	109
4.16	JTAG Test Operation	109
4.17	Device Power-Up	109
4.18	Device Reset	110
5	Application Reference Design	111
5.1	Typical Application Circuit	111
6	References & Relevant Standards	112

7. Package & Ordering Information	113
7.1 Package Dimensions	113
7.2 Packaging Data	114
7.3 Marking Diagram	114
7.4 Solder Reflow Profiles	115
7.5 Ordering Information	115

List of Figures

Figure 1-1: Pin Assignment	9
Figure 3-1: Differential Output Stage (SDO/ \overline{SDO})	24
Figure 3-2: Digital Input Pin (20bit/10bit, $\overline{ANC_BLANK}$, $\overline{DETECT_TRS}$, $\overline{DVB_ASI}$, $\overline{RATE_SEL}$, $\overline{SMPT_BYPASS}$, $\overline{TIM_861}$, $\overline{F/DE}$, $\overline{H/HSYNC}$, \overline{PCLK} , $\overline{V/VSYNC}$)	24
Figure 3-3: Digital Input Pin with Schmitt Trigger (\overline{RESET})	24
Figure 3-4: Digital Input Pin with weak pull-down - maximum pull-down current <110 μ A (JTAG/ \overline{HOST} , $\overline{STANDBY}$, $\overline{SCLK_TCK}$, $\overline{SDIN_TDI}$, \overline{TCK} , \overline{TDI})	24
Figure 3-5: Digital Input Pin with weak pull-up - maximum pull-up current <110 μ A ($\overline{ACLK1}$, $\overline{ACLK2}$, $\overline{AIN_7/8}$, $\overline{AIN_5/6}$, $\overline{AIN_3/4}$, $\overline{AIN_1/2}$, $\overline{CS_TMS}$, $\overline{GRP1_EN/DIS}$, $\overline{GRP2_EN/DIS}$, $\overline{IOPROC_EN/DIS}$, $\overline{SDO_EN/DIS}$, \overline{TMS} , $\overline{WCLK1}$, $\overline{WCLK2}$)	25
Figure 3-6: Bidirectional Digital Input/Output Pin with programmable drive strength. These pins are configured to input at all times except in test mode. ($\overline{DIN0}$, $\overline{DIN2}$, $\overline{DIN3}$, $\overline{DIN4}$, $\overline{DIN5}$, $\overline{DIN6}$, $\overline{DIN7}$, $\overline{DIN8}$, $\overline{DIN9}$, $\overline{DIN10}$, $\overline{DIN11}$, $\overline{DIN12}$, $\overline{DIN13}$, $\overline{DIN14}$, $\overline{DIN15}$, $\overline{DIN16}$, $\overline{DIN17}$, $\overline{DIN18}$, $\overline{DIN19}$, $\overline{DIN1}$)	25
Figure 3-7: Bidirectional Digital Input/Output Pin with programmable drive strength. These pins are configured to output at all times except in reset mode. (\overline{LOCKED} , $\overline{AUDIO_INT}$, $\overline{SDOUT_TDO}$, \overline{TDO})	25
Figure 3-8: VBG	25
Figure 3-9: Loop Filter	25
Figure 4-1: GS1672 Video Host Interface Timing Diagrams	26
Figure 4-2: H:V:F Input Timing - HD 20-bit Input Mode	30
Figure 4-3: H:V:F Input Timing - HD 10-bit Input Mode	31
Figure 4-4: H:V:F Input Timing - SD 20-bit Mode	31
Figure 4-5: H:V:F Input Timing - SD 10-bit Mode	31
Figure 4-6: H:V:DE Input Timing 1280 x 720p @ 59.94/60 (Format 4)	33
Figure 4-7: H:V:DE Input Timing 1920 x 1080i @ 59.94/60 (Format 5)	33
Figure 4-8: H:V:DE Input Timing 720 (1440) x 480i @ 59.94/60 (Format 6&7)	34
Figure 4-9: H:V:DE Input Timing 1280 x 720p @ 50 (Format 19)	34
Figure 4-10: H:V:DE Input Timing 1920 x 1080i @ 50 (Format 20)	35
Figure 4-11: H:V:DE Input Timing 720 (1440) x 576 @ 50 (Format 21&22)	35
Figure 4-12: H:V:DE Input Timing 1920 x 1080p @ 23.94/24 (Format 32)	36
Figure 4-13: H:V:DE Input Timing 1920 x 1080p @ 25 (Format 33)	36
Figure 4-14: H:V:DE Input Timing 1920 x 1080p @ 29.97/30 (Format 34)	37
Figure 4-15: \overline{ACLK} to Data and Control Signal Input Timing	40
Figure 4-16: I ² S Audio Input Format	41
Figure 4-17: AES/EBU Audio Input Format	42
Figure 4-18: Serial Audio, Left Justified, MSB First	42
Figure 4-19: Serial Audio, Left Justified, LSB First	42
Figure 4-20: Serial Audio, Right Justified, MSB First	42
Figure 4-21: Serial Audio, Right Justified, LSB First	42
Figure 4-22: Ancillary Data Packet Placement Example for SD Mode	44
Figure 4-23: ORL Matching Network, BNC, and Coaxial Cable Connection	71
Figure 4-24: GSPI Application Interface Connection	74
Figure 4-25: Command Word Format	74
Figure 4-26: Data Word Format	75
Figure 4-27: Write Mode	75
Figure 4-28: Read Mode	76
Figure 4-29: GSPI Time Delay	76
Figure 4-30: Reset Pulse	110
Figure 5-1: Typical Application Circuit	111
Figure 7-1: Package Dimensions	113
Figure 7-2: Marking Diagram	114
Figure 7-3: Pb-free Solder Reflow Profile	115

List of Tables

Table 1-1: Pin Descriptions	10
Table 2-1: Absolute Maximum Ratings.....	19
Table 2-2: Recommended Operating Conditions.....	19
Table 2-3: DC Electrical Characteristics.....	20
Table 2-4: AC Electrical Characteristics.....	21
Table 4-1: GS1672 Digital Input AC Electrical Characteristics	27
Table 4-2: GS1672 Input Video Data Format Selections	27
Table 4-3: GS1672 PCLK Input Rates	29
Table 4-4: CEA861 Timing Formats.....	32
Table 4-5: Serial Audio Input Pin Description	39
Table 4-6: GS1672 Serial Audio Data Inputs - AC Electrical Characteristics	40
Table 4-7: Audio Input Formats	41
Table 4-8: GS1672 Audio Operating Mode Selection.....	43
Table 4-9: GS1672 SD Audio Crosspoint Channel Selection.....	46
Table 4-10: Audio Source Host Interface Fields.....	46
Table 4-11: GS1672 SD Audio Buffer Size Selection.....	48
Table 4-12: GS1672 SD Audio Five Frame Sequence Sample Count.....	50
Table 4-13: GS1672 SD Audio Group 1 Audio Sample Distribution - 525 line	50
Table 4-14: GS1672 SD Audio Group 2 Audio Sample Distribution - 525 line	51
Table 4-15: GS1672 SD Audio Group 3 Audio Sample Distribution - 525 line	51
Table 4-16: GS1672 SD Audio Group 4 Audio Sample Distribution - 525 line	51
Table 4-17: GS1672 SD Audio Group 1 Audio Sample Distribution - 625 line	51
Table 4-18: GS1672 SD Audio Group 2 Audio Sample Distribution - 625 line	52
Table 4-19: GS1672 SD Audio Group 3 Audio Sample Distribution - 625 line	52
Table 4-20: GS1672 SD Audio Group 4 Audio Sample Distribution - 625 line	52
Table 4-21: Audio Interrupt Control – Host Interface Bit Description	56
Table 4-22: Supported Video Standards	61
Table 4-23: IOPROC Register Bits.....	67
Table 4-24: SMPTE ST 352 Packet Data.....	68
Table 4-25: PCLK and Serial Digital Clock Rates	69
Table 4-26: GS1672 PLL Bandwidth.....	70
Table 4-27: GS1672 Lock Detect Indication	70
Table 4-28: Serial Digital Output - Serial Output Data Rate	71
Table 4-29: R _{SET} Resistor Value vs. Output Swing.....	72
Table 4-30: Serial Digital Output - Overshoot/Undershoot	72
Table 4-31: Serial Digital Output - Rise/Fall Time	73
Table 4-32: GSPI Time Delay.....	76
Table 4-33: GSPI AC Characteristics	76
Table 4-34: Video Core Configuration and Status Registers.....	78
Table 4-35: SD Audio Core Configuration and Status Registers.....	88
Table 4-36: HD Audio Core Configuration and Status Registers.....	100
Table 7-1: Packaging Data.....	114
Table 7-2: Ordering Information.....	115

1. Pin Out

1.1 Pin Assignment

	1	2	3	4	5	6	7	8	9	10
A	DIN17	DIN18	F/DE	H/HSYNC	CORE_VDD	PLL_VDD	LF	VBG	RSV	A_VDD
B	DIN15	DIN16	DIN19	PCLK	CORE_GND	PLL_VDD	VCO_VDD	VCO_GND	A_GND	A_GND
C	DIN13	DIN14	DIN12	V/VSYNC	CORE_GND	PLL_GND	PLL_GND	PLL_GND	CD_GND	SDO
D	DIN11	DIN10	STANDBY	SDO_EN/DIS	RSV	RSV	RSV	RSV	CD_GND	$\overline{\text{SDO}}$
E	CORE_VDD	CORE_GND	RATE_SEL	IO_GND	CORE_GND	CORE_GND	TDI	TMS	CD_GND	CD_VDD
F	DIN9	DIN8	DETECT_TRS	RSV	CORE_GND	CORE_GND	RSV	TDO	CD_GND	RSET
G	IO_VDD	IO_GND	TIM_861	$\frac{20\text{bit}}{10\text{bit}}$	DVB_ASI	$\overline{\text{SMPTE}}_{\text{BYPASS}}$	IOPROC_EN/DIS	$\overline{\text{RESET}}$	CORE_GND	CORE_VDD
H	DIN7	DIN6	$\overline{\text{ANC}}_{\text{BLANK}}$	LOCKED	GRP2_EN/DIS	GRP1_EN/DIS	AUDIO_INT	JTAG/HOST	IO_GND	IO_VDD
J	DIN5	DIN4	DIN1	AIN_5/6	WCLK2	AIN_1/2	WCLK1	TCK	SDOUT_TDO	SCLK_TCK
K	DIN3	DIN2	DIN0	AIN_7/8	ACLK2	AIN_3/4	ACLK1	CORE_VDD	$\overline{\text{CS}}_{\text{TMS}}$	SDIN_TDI

Figure 1-1: Pin Assignment

1.2 Pin Descriptions

Table 1-1: Pin Descriptions

Pin Number	Name	Timing	Type	Description
				Parallel data bus. Please refer to the Input Logic parameters in the DC Electrical Characteristics table for logic level threshold and compatibility.
B3, A2, A1, B2, B1, C2, C1, C3, D1, D2	DIN[19:10]		Input	<p>20-bit mode 20BIT/T0BIT = HIGH</p> <p>Luma data input in SMPTE mode (SMPTE_BYPASS = HIGH) Data input in data through mode (SMPTE_BYPASS = LOW)</p> <hr/> <p>10-bit mode 20BIT/T0BIT = LOW</p> <p>Multiplexed Luma and Chroma data input in SMPTE mode (SMPTE_BYPASS = HIGH) Data input in data through mode (SMPTE_BYPASS = LOW) DVB-ASI data input in DVB-ASI mode (SMPTE_BYPASS = LOW) (DVB_ASI = HIGH)</p>
A3	F/DE	Synchronous with PCLK	Input	<p>Parallel data timing. Please refer to the Input Logic parameters in the DC Electrical Characteristics table for logic level threshold and compatibility.</p> <p>TIM_861 = LOW: Used to indicate the ODD / EVEN field of the video signal when DETECT_TRS is set LOW. The device will set the F bit in all outgoing TRS signals for the entire period that the F input signal is HIGH (IOPROC_EN/DIS must also be HIGH). The F signal should be set HIGH for the entire period of field 2 and should be set LOW for all lines in field 1 and for all lines in progressive scan systems. The F signal is ignored when DETECT_TRS = HIGH.</p> <p>TIM_861 = HIGH: The DE signal is used to indicate the active video period when DETECT_TRS is LOW. DE is HIGH for active data and LOW for blanking. See Section 4.3 and Section 4.3.2 for timing details. The DE signal is ignored when DETECT_TRS = HIGH.</p>

Table 1-1: Pin Descriptions (Continued)

Pin Number	Name	Timing	Type	Description	
A4	H/HSYNC	Synchronous with PCLK	Input	<p>Parallel data timing. Please refer to the Input Logic parameters in the DC Electrical Characteristics table for logic level threshold and compatibility.</p> <p>TIM_861 is LOW: The H signal is used to indicate the portion of the video line containing active video data, when DETECT_TRS is set LOW.</p> <p>Active Line Blanking The H signal should be LOW for the active portion of the video line. The signal goes LOW at the first active pixel of the line, and then goes HIGH after the last active pixel of the line. The H signal should be set HIGH for the entire horizontal blanking period, including both EAV and SAV TRS words, and LOW otherwise.</p> <p>TRS Based Blanking (H_CONFIG = 1_H) The H signal should be set HIGH for the entire horizontal blanking period as indicated by the H bit in the received TRS ID words, and LOW otherwise.</p> <p>TIM_861 = HIGH: The HSYNC signal indicates horizontal timing. See Section 4.3. When DETECT_TRS is HIGH, this pin is ignored at all times. If DETECT_TRS is set HIGH and TIM_861 is set HIGH, the DETECT_TRS feature will take priority.</p>	
A5, E1, G10, K8	CORE_VDD		Input Power	Power supply connection for digital core logic. Connect to +1.2V DC digital.	
A6, B6	PLL_VDD		Input Power	Power supply pin for PLL. Connect to +1.2V DC analog.	
A7	LF		Analog Output	Loop Filter component connection.	
A8	VBG		Output	Bandgap voltage filter connection.	
A9, D6, D7, D8, F4	RSV		–	These pins are reserved and should be left unconnected.	
A10	A_VDD		Input Power	VDD for sensitive analog circuitry. Connect to +3.3VDC analog.	
B4	PCLK		Input	Parallel data bus clock. Please refer to the Input Logic parameters in the DC Electrical Characteristics table for logic level threshold and compatibility.	
				HD 20-bit mode	PCLK @ 74.25MHz
				HD 10-bit mode	PCLK @ 148.5MHz
				SD 20-bit mode	PCLK @ 13.5MHz
				SD 10-bit mode	PCLK @ 27MHz
				DVB-ASI mode	PCLK @ 27MHz
B5, C5, E2, E5, E6, F5, F6, G9	CORE_GND		Input Power	GND connection for digital logic. Connect to digital GND.	

Table 1-1: Pin Descriptions (Continued)

Pin Number	Name	Timing	Type	Description
B7	VCO_VDD		Input Power	Power pin for the VCO. Connect to a +1.2V±5% analog supply, followed by a RC filter (see Typical Application Circuit on page 111). A 105Ω 1% resistor must be used in the RC filter circuit. VCO_VDD is nominally 0.7V.
B8	VCO_GND		Input Power	Ground connection for VCO. Connect to analog GND.
B9, B10	A_GND		Input Power	GND pins for sensitive analog circuitry. Connect to analog GND.
C4	V/VSYNC	Synchronous with PCLK	Input	<p>Parallel data timing. Please refer to the Input Logic parameters in the DC Electrical Characteristics table for logic level threshold and compatibility.</p> <p>TIM_861 = LOW: The V signal is used to indicate the portion of the video field/frame that is used for vertical blanking, when DETECT_TRS is set LOW. The V signal should be set HIGH for the entire vertical blanking period and should be set LOW for all lines outside of the vertical blanking interval. The V signal is ignored when DETECT_TRS = HIGH.</p> <p>TIM_861 = HIGH: The VSYNC signal indicates vertical timing. See Section 4.3 for timing details. The VSYNC signal is ignored when DETECT_TRS = HIGH.</p>
C6, C7, C8	PLL_GND		Input Power	Ground connection for PLL. Connect to analog GND.
C9, D9, E9, F9	CD_GND		Input Power	Ground connection for the serial digital cable driver. Connect to analog GND.
C10, D10	SDO, $\overline{\text{SDO}}$		Output	<p>Serial Data Output Signal. Serial digital output signal operating at 1.485Gb/s, 1.485 /1.001Gb/s, or 270Mb/s. The slew rate of the output is automatically controlled to meet SMPTE ST 292 and SMPTE ST 259-C specifications according to the setting of the RATE_SEL pin.</p>
D3	STANDBY		Input	<p>Power Down input. HIGH to power down device.</p>
D4	SDO_EN/ $\overline{\text{DIS}}$		Input	<p>Control signal input. Please refer to the Input Logic parameters in the DC Electrical Characteristics table for logic level threshold and compatibility.</p> <p>Used to enable or disable the serial digital output stage. When SDO_EN/$\overline{\text{DIS}}$ is LOW, the serial digital output signals SDO and $\overline{\text{SDO}}$ are disabled and become high impedance. When SDO_EN/$\overline{\text{DIS}}$ is HIGH, the serial digital output signals SDO and $\overline{\text{SDO}}$ are enabled.</p>
D5, F7	RSV		–	These pins are reserved and should be connected to CORE_GND.

Table 1-1: Pin Descriptions (Continued)

Pin Number	Name	Timing	Type	Description															
E3	RATE_SEL		Input	<p>Control signal input. Please refer to the Input Logic parameters in the DC Electrical Characteristics table for logic level threshold and compatibility. Used to configure the operating data rate.</p> <table border="1"> <thead> <tr> <th>RATE_SEL</th> <th>Data Rate</th> </tr> </thead> <tbody> <tr> <td>0</td> <td>1.485 or 1.485/1.001Gb/s</td> </tr> <tr> <td>1</td> <td>270Mb/s</td> </tr> </tbody> </table>	RATE_SEL	Data Rate	0	1.485 or 1.485/1.001Gb/s	1	270Mb/s									
RATE_SEL	Data Rate																		
0	1.485 or 1.485/1.001Gb/s																		
1	270Mb/s																		
E7	TDI		Input	<p>Communication signal input. Please refer to the Input Logic parameters in the DC Electrical Characteristics table for logic level threshold and compatibility. Dedicated JTAG pin. Test data in. This pin is used to shift JTAG test data into the device when the JTAG/HOST pin is LOW.</p>															
E8	TMS		Input	<p>Communication signal input. Please refer to the Input Logic parameters in the DC Electrical Characteristics table for logic level threshold and compatibility. Dedicated JTAG pin. Test mode start. This pin is JTAG Test Mode Start, used to control the operation of the JTAG test when the JTAG/HOST pin is LOW.</p>															
E10	CD_VDD		Input Power	Power for the serial digital cable driver. Connect to +3.3V DC analog.															
F1, F2, H1, H2, J1, J2, K1, K2, J3, K3	DIN[9:0]		Input	<p>Parallel data bus. Please refer to the Input Logic parameters in the DC Electrical Characteristics table for logic level threshold and compatibility. In 10-bit mode, these pins are not used.</p> <table border="1"> <thead> <tr> <th>Mode</th> <th>Configuration</th> <th>Description</th> </tr> </thead> <tbody> <tr> <td>20-bit mode</td> <td>20BIT/$\overline{10BIT}$ = HIGH</td> <td>Chroma data input in SMPTE mode SMPTE_BYPASS = HIGH DVB_ASI = LOW</td> </tr> <tr> <td>20-bit mode</td> <td>20BIT/$\overline{10BIT}$ = HIGH</td> <td>Data input in data through mode SMPTE_BYPASS = LOW DVB_ASI = LOW</td> </tr> <tr> <td>10-bit mode</td> <td>20BIT/$\overline{10BIT}$ = LOW</td> <td>Not Used in DVB-ASI mode SMPTE_BYPASS = LOW DVB_ASI = HIGH</td> </tr> <tr> <td>10-bit mode</td> <td>20BIT/$\overline{10BIT}$ = LOW</td> <td>High impedance.</td> </tr> </tbody> </table>	Mode	Configuration	Description	20-bit mode	20BIT/ $\overline{10BIT}$ = HIGH	Chroma data input in SMPTE mode SMPTE_BYPASS = HIGH DVB_ASI = LOW	20-bit mode	20BIT/ $\overline{10BIT}$ = HIGH	Data input in data through mode SMPTE_BYPASS = LOW DVB_ASI = LOW	10-bit mode	20BIT/ $\overline{10BIT}$ = LOW	Not Used in DVB-ASI mode SMPTE_BYPASS = LOW DVB_ASI = HIGH	10-bit mode	20BIT/ $\overline{10BIT}$ = LOW	High impedance.
Mode	Configuration	Description																	
20-bit mode	20BIT/ $\overline{10BIT}$ = HIGH	Chroma data input in SMPTE mode SMPTE_BYPASS = HIGH DVB_ASI = LOW																	
20-bit mode	20BIT/ $\overline{10BIT}$ = HIGH	Data input in data through mode SMPTE_BYPASS = LOW DVB_ASI = LOW																	
10-bit mode	20BIT/ $\overline{10BIT}$ = LOW	Not Used in DVB-ASI mode SMPTE_BYPASS = LOW DVB_ASI = HIGH																	
10-bit mode	20BIT/ $\overline{10BIT}$ = LOW	High impedance.																	

Table 1-1: Pin Descriptions (Continued)

Pin Number	Name	Timing	Type	Description
F3	DETECT_TRS		Input	<p>Control signal input.</p> <p>Please refer to the Input Logic parameters in the DC Electrical Characteristics table for logic level threshold and compatibility.</p> <p>Used to select external HVF timing mode or TRS extraction timing mode.</p> <p>When DETECT_TRS is LOW, the device extracts all internal timing from the supplied H:V:F or CEA-861 timing signals, dependent on the status of the TIM861 pin.</p> <p>When DETECT_TRS is HIGH, the device extracts all internal timing from TRS signals embedded in the supplied video stream.</p>
F8	TDO		Output	<p>Communication signal output.</p> <p>Please refer to the Output Logic parameters in the DC Electrical Characteristics table for logic level threshold and compatibility.</p> <p>Dedicated JTAG pin.</p> <p>JTAG Test Data Output.</p> <p>This pin is used to shift results from the device when the JTAG/$\overline{\text{HOST}}$ pin is LOW.</p>
F10	RSET		Input	<p>An external 1% resistor connected to this input is used to set the SDO/$\overline{\text{SDO}}$ output signal amplitude.</p>
G1, H10	IO_VDD		Input Power	<p>Power connection for digital I/O. Connect to +3.3V or +1.8V DC digital.</p>
E4, G2, H9	IO_GND		Input Power	<p>Ground connection for digital I/O. Connect to digital GND.</p>
G3	TIM_861		Input	<p>Control signal input.</p> <p>Please refer to the Input Logic parameters in the DC Electrical Characteristics table for logic level threshold and compatibility.</p> <p>Used to select external CEA-861 timing mode.</p> <p>When DETECT_TRS is LOW and TIM-861 is LOW, the device extracts all internal timing from the supplied H:V:F timing signals.</p> <p>When DETECT_TRS is LOW and TIM-861 is HIGH, the device extracts all internal timing from the supplied HSYNC, VSYNC, DE timing signals.</p> <p>When DETECT_TRS is HIGH, the device extracts all internal timing from TRS signals embedded in the supplied video stream.</p>
G4	20BIT/ $\overline{\text{10BIT}}$		Input	<p>Control signal input.</p> <p>Please refer to the Input Logic parameters in the DC Electrical Characteristics table for logic level threshold and compatibility.</p> <p>Used to select the input bus width.</p>

Table 1-1: Pin Descriptions (Continued)

Pin Number	Name	Timing	Type	Description
G5	DVB_ASI		Input	<p>Control signal input.</p> <p>Please refer to the Input Logic parameters in the DC Electrical Characteristics table for logic level threshold and compatibility.</p> <p>Used to enable/disable the DVB-ASI data transmission.</p> <p>When DVB_ASI is set HIGH and $\overline{\text{SMPTE_BYPASS}}$ is set LOW, then the device will carry out DVB-ASI word alignment, I/O processing and transmission.</p> <p>When $\overline{\text{SMPTE_BYPASS}}$ and DVB_ASI are both set LOW, the device operates in data-through mode.</p>
G6	$\overline{\text{SMPTE_BYPASS}}$		Input	<p>Control signal input.</p> <p>Please refer to the Input Logic parameters in the DC Electrical Characteristics table for logic level threshold and compatibility.</p> <p>Used to enable / disable all forms of encoding / decoding, scrambling and EDH insertion.</p> <p>When set LOW, the device operates in data through mode (DVB_ASI= LOW), or in DVB-ASI mode (DVB_ASI = HIGH).</p> <p>No SMPTE scrambling takes place and none of the I/O processing features of the device are available when $\overline{\text{SMPTE_BYPASS}}$ is set LOW.</p> <p>When set HIGH, the device carries out SMPTE scrambling and I/O processing.</p>
G7	IOPROC_EN/ $\overline{\text{DIS}}$		Input	<p>Control signal input.</p> <p>Please refer to the Input Logic parameters in the DC Electrical Characteristics table for logic level threshold and compatibility.</p> <p>Used to enable or disable the I/O processing features.</p> <p>When IOPROC_EN/$\overline{\text{DIS}}$ is HIGH, the I/O processing features of the device are enabled. When IOPROC_EN/$\overline{\text{DIS}}$ is LOW, the I/O processing features of the device are disabled.</p> <p>Only applicable in SMPTE mode.</p>
G8	$\overline{\text{RESET}}$		Input	<p>Control signal input.</p> <p>Please refer to the Input Logic parameters in the DC Electrical Characteristics table for logic level threshold and compatibility.</p> <p>Used to reset the internal operating conditions to default settings and to reset the JTAG sequence.</p> <p>Normal mode (JTAG/$\overline{\text{HOST}}$ = LOW).</p> <p>When LOW, all functional blocks will be set to default conditions and all input and output signals become high-impedance.</p> <p>When HIGH, normal operation of the device resumes.</p> <p>JTAG test mode (JTAG/$\overline{\text{HOST}}$ = HIGH).</p> <p>When LOW, all functional blocks will be set to default and the JTAG test sequence will be reset.</p> <p>When HIGH, normal operation of the JTAG test sequence resumes.</p>

Table 1-1: Pin Descriptions (Continued)

Pin Number	Name	Timing	Type	Description
H3	$\overline{\text{ANC_BLANK}}$		Input	Control signal input. Please refer to the Input Logic parameters in the DC Electrical Characteristics table for logic level threshold and compatibility. When $\overline{\text{ANC_BLANK}}$ is LOW, the Luma and Chroma input data is set to the appropriate blanking levels during the H and V blanking intervals. When $\overline{\text{ANC_BLANK}}$ is HIGH, the Luma and Chroma data pass through the device unaltered. Only applicable in SMPTE mode.
H4	LOCKED		Output	Status signal output. Please refer to the Output Logic parameters in the DC Electrical Characteristics table for logic level threshold and compatibility. PLL lock indication. HIGH indicates PLL is locked. LOW indicates PLL is not locked.
H5	$\overline{\text{GRP2_EN/DIS}}$		Input	Enables Audio Group 2 embedding. Set HIGH to enable.
H6	$\overline{\text{GRP1_EN/DIS}}$		Input	Enables Audio Group 1 embedding. Set HIGH to enable.
H7	AUDIO_INT		Output	Status signal output. Please refer to the Output Logic parameters in the DC Electrical Characteristics table for logic level threshold and compatibility. Summary Interrupt from Audio Processing. This signal is set HIGH by the device to indicate a problem with the audio processing which requires the Host processor to interrogate the interrupt status registers. IO_VDD = +3.3V Drive Strength = 8mA IO_VDD = +1.8V Drive Strength = 4mA Note: By default, out of reset, the AUDIO_INT pin will output the HD_AUDIO_CLOCK, rather than the audio interrupt signal. In order to output the interrupt flags from the audio core as intended, the user must write 0001h to register 0232h.
H8	$\overline{\text{JTAG/HOST}}$		Input	Control signal input. Please refer to the Input Logic parameters in the DC Electrical Characteristics table for logic level threshold and compatibility. Used to select JTAG test mode or host interface mode. When $\overline{\text{JTAG/HOST}}$ is HIGH, the host interface port is configured for JTAG test. When $\overline{\text{JTAG/HOST}}$ is LOW, normal operation of the host interface port resumes and the separate JTAG pins become the JTAG port.
J4	AIN_5/6		Input	Serial Audio Input; Channels 5 and 6.
J5	WCLK2		Input	48kHz Word Clock associated with AIN_5/6 and AIN_7/8 (channels 5, 6, 7, and 8).

Table 1-1: Pin Descriptions (Continued)

Pin Number	Name	Timing	Type	Description
J6	AIN_1/2		Input	Serial Audio Input; Channels 1 and 2.
J7	WCLK1		Input	48kHz Word Clock associated with AIN_1/2 and AIN_3/4 (channels 1, 2, 3, and 4).
J8	TCK		Input	Communication signal input. Please refer to the Input Logic parameters in the DC Electrical Characteristics table for logic level threshold and compatibility. JTAG Serial Data Clock Signal. This pin is the JTAG clock when the JTAG/ $\overline{\text{HOST}}$ pin is LOW.
J9	SDOUT_TDO		Output	Communication signal output. Please refer to the Output Logic parameters in the DC Electrical Characteristics table for logic level threshold and compatibility. Shared JTAG/ $\overline{\text{HOST}}$ pin. Provided for compatibility with the GS1582. Serial Data Output/Test Data Output. Host Mode (JTAG/ $\overline{\text{HOST}}$ = LOW) This pin operates as the host interface serial output, used to read status and configuration information from the internal registers of the device. JTAG Test Mode (JTAG/ $\overline{\text{HOST}}$ = HIGH) This pin is used to shift test results and operates as the JTAG test data output, TDO (for new designs, use the dedicated JTAG port). Note: If the host interface is not being used leave this pin unconnected. IO_VDD = +3.3V Drive Strength = 12mA IO_VDD = +1.8V Drive Strength = 4mA
J10	SCLK_TCK		Input	Communication signal input. Please refer to the Input Logic parameters in the DC Electrical Characteristics table for logic level threshold and compatibility. Shared JTAG/ $\overline{\text{HOST}}$ pin. Provided for pin compatibility with GS1582. Serial data clock signal. Host Mode (JTAG/ $\overline{\text{HOST}}$ = LOW) SCLK_TCK operates as the host interface burst clock, SCLK. Command and data read/write words are clocked into the device synchronously with this clock. JTAG Test Mode (JTAG/ $\overline{\text{HOST}}$ = HIGH) This pin is the TEST MODE START pin, used to control the operation of the JTAG test clock, TCK (for new designs, use the dedicated JTAG port). Note: If the host interface is not being used, tie this pin HIGH.
K4	AIN_7/8		Input	Serial Audio Input; Channels 7 and 8.
K5	ACLK2		Input	64 x WCLK associated with AIN_5/6 and AIN_7/8 (channels 5, 6, 7, and 8).
K6	AIN_3/4		Input	Serial Audio Input; Channels 3 and 4.

Table 1-1: Pin Descriptions (Continued)

Pin Number	Name	Timing	Type	Description
K7	ACLK1		Input	64 x WCLK associated with AIN_1/2 and AIN_3/4 (channels 1, 2, 3, and 4).
K9	$\overline{\text{CS}}_{\text{TMS}}$		Input	Communication signal input. Please refer to the Input Logic parameters in the DC Electrical Characteristics table for logic level threshold and compatibility. Chip select/test mode start. JTAG Test mode ($\text{JTAG}/\overline{\text{HOST}} = \text{HIGH}$) $\overline{\text{CS}}_{\text{TMS}}$ operates as the JTAG test mode start, TMS, used to control the operation of the JTAG test, and is active HIGH (for new designs, use the dedicated JTAG port). Host mode ($\text{JTAG}/\overline{\text{HOST}} = \text{LOW}$), $\overline{\text{CS}}_{\text{TMS}}$ operates as the host interface Chip Select, $\overline{\text{CS}}$, and is active LOW.
K10	SDIN_TDI		Input	Communication signal input. Please refer to the Input Logic parameters in the DC Electrical Characteristics table for logic level threshold and compatibility. Shared JTAG/HOST pin. Provided for pin compatibility with GS1582. Serial data in/test data in. In JTAG mode, this pin is used to shift test data into the device (for new designs, use the dedicated JTAG port). In host interface mode, this pin is used to write address and configuration data words into the device.

2. Electrical Characteristics

2.1 Absolute Maximum Ratings

Table 2-1: Absolute Maximum Ratings

Parameter	Value/Units
Supply Voltage, Digital Core (CORE_VDD)	-0.3V to +1.5V
Supply Voltage, Digital I/O (IO_VDD)	-0.3V to +3.6V
Supply Voltage, Analog +1.2V (PLL_VDD, VCO_VDD)	-0.3V to +1.5V
Supply Voltage, Analog +3.3V (CD_VDD, A_VDD)	-0.3V to +3.6V
Input Voltage Range (digital inputs)	-2.0V to +5.25V
Temperature Range	-40°C to +85°C
Storage Temperature Range	-40°C to +125°C
Peak Reflow Temperature (JEDEC J-STD-020C)	260°C
ESD Sensitivity, HBM (JESD22-A114)	2kV

Note: Absolute Maximum Ratings are those values beyond which damage may occur. Functional operation outside of the ranges shown in [Table 2-1](#) is not implied.

2.2 Recommended Operating Conditions

Table 2-2: Recommended Operating Conditions

Parameter	Symbol	Conditions	Min	Typ	Max	Units	Notes
Operating Temperature Range, Ambient	T _A	–	-20	–	85	°C	–
Supply Voltage, Digital Core	CORE_VDD	–	1.14	1.2	1.26	V	–
Supply Voltage, Digital I/O	IO_VDD	+1.8V mode	1.71	1.8	1.89	V	–
		+3.3V mode	3.13	3.3	3.47	V	–
Supply Voltage, PLL	PLL_VDD	–	1.14	1.2	1.26	V	–
Supply Voltage, Analog	A_VDD	–	3.13	3.3	3.47	V	–
Supply Voltage, CD	CD_VDD	–	3.13	3.3	3.47	V	–
Operating Temperature Range	–	–	-20	–	85	°C	1
Functional Temperature Range	–	–	-40	–	85	°C	1

Note:

1. Operating Temperature Range guarantees the parameters given in the [DC Electrical Characteristics](#) and [AC Electrical Characteristics](#). Functional Temperature Range guarantees a device start-up.

2.3 DC Electrical Characteristics

Table 2-3: DC Electrical Characteristics

$V_{CC} = +3.3V \pm 5\%$, $T_A = -20^\circ C$ to $+85^\circ C$, unless otherwise shown

Parameter	Symbol	Conditions	Min	Typ	Max	Units	Notes
System							
+1.2V Supply Current		10/20bit HD	-	100	160	mA	-
		10/20bit SD	-	75	120	mA	-
		DVB_ASI	-	75	120	mA	-
+1.8V Supply Current		10/20bit HD	-	15	32	mA	-
		10/20bit SD	-	3	10	mA	-
		DVB_ASI	-	3	10	mA	-
+3.3V Supply Current		10/20bit HD	-	90	110	mA	-
		10/20bit SD	-	70	90	mA	-
		DVB_ASI	-	70	90	mA	-
Total Device Power (IO_VDD = +1.8V)		10/20bit HD	-	350	510	mW	-
		10/20bit SD	-	300	450	mW	-
		DVB_ASI	-	300	450	mW	-
		Reset	-	200	-	mW	-
	Standby	-	110	180	mW	1	
Total Device Power (IO_VDD = +3.3V)		10/20bit HD	-	420	550	mW	-
		10/20bit SD	-	320	450	mW	-
		DVB_ASI	-	320	450	mW	-
		Reset	-	230	-	mW	-
		Standby	-	110	180	mW	-
Digital I/O							
Input Logic LOW	V_{IL}	+3.3V or +1.8V operation	$IO_VSS-0.3$	-	$0.3 \times IO_VDD$	V	-
Input Logic HIGH	V_{IH}	+3.3V or +1.8V operation	$0.7 \times IO_VDD$	-	$IO_VDD+0.3$	V	-
Output Logic LOW	V_{OL}	IOL=5mA, +1.8V operation	-	-	0.2	V	-
		IOL=8mA, +3.3V operation	-	-	0.4	V	-
Output Logic HIGH	V_{OH}	IOH=-5mA, +1.8V operation	1.4	-	-	V	-
		IOH=-8mA, +3.3V operation	2.4	-	-	V	-

Table 2-3: DC Electrical Characteristics (Continued)

$V_{CC} = +3.3V \pm 5\%$, $T_A = -20^\circ C$ to $+85^\circ C$, unless otherwise shown

Parameter	Symbol	Conditions	Min	Typ	Max	Units	Notes
Serial Output							
Serial Output Common Mode Voltage	V_{CMOUT}	75 Ω load, RSET = 750 Ω SD and HD mode	-	CD_VDD - $V_{SDD}/2$	-	V	-

Note:

1. Devices manufactured prior to April 1, 2011 consume 150mW of power in Standby mode.

2.4 AC Electrical Characteristics

Table 2-4: AC Electrical Characteristics

$V_{CC} = +3.3V \pm 5\%$, $T_A = -20^\circ C$ to $+85^\circ C$, unless otherwise shown

Parameter	Symbol	Conditions	Min	Typ	Max	Units	Notes
System							
Device Latency	-	HD bypass (PCLK = 74.25MHz)	-	54	-	PCLK	-
	-	HD SMPTE without audio (PCLK = 74.25MHz)	-	95	-	PCLK	-
	-	HD SMPTE with audio (PCLK = 74.25MHz)	-	1106	-	PCLK	-
	-	SD bypass (PCLK = 27 MHz)	-	54	-	PCLK	-
	-	SD SMPTE without audio	-	112	-	PCLK	-
	-	SD SMPTE with audio	-	638	-	PCLK	-
	-	DVB-ASI	-	52	-	PCLK	-
Reset Pulse Width	t_{reset}	-	1	-	-	ms	-
Parallel Input							
Parallel Clock Frequency	f_{PCLK}	-	13.5	-	148.5	MHz	-
Parallel Clock Duty Cycle	DC _{PCLK}	-	40	-	60	%	-
Input Data Setup Time	t_{su}	50% levels; +3.3V or +1.8V operation	1.2	-	-	ns	1
Input Data Hold Time	t_{ih}	50% levels; +3.3V or +1.8V operation	0.8	-	-	ns	1
Serial Digital Output							
Serial Output Data Rate	DR_{SDO}	-	-	1.485	-	Gb/s	-
		-	-	1.485/1.001	-	Gb/s	-
		-	-	270	-	Mb/s	-

Table 2-4: AC Electrical Characteristics (Continued)
 $V_{CC} = +3.3V \pm 5\%$, $T_A = -20^\circ C$ to $+85^\circ C$, unless otherwise shown

Parameter	Symbol	Conditions	Min	Typ	Max	Units	Notes	
Serial Output Swing	V_{SDD}	RSET = 750Ω 75Ω load	750	800	850	mVpp	2	
Serial Output Rise/Fall Time 20% ~ 80%	trf_{SDO}	HD mode	–	120	135	ps	–	
	trf_{SDO}	SD mode	400	660	800	ps	–	
Mismatch in rise/fall time	$\Delta t_r, \Delta t_f$	–	–	–	35	ps	–	
Duty Cycle Distortion	–	–	–	–	5	%	2	
Overshoot	–	HD mode	–	5	10	%	2	
	–	SD mode	–	3	8	%	2	
Output Return Loss	ORL	5 MHz - 1.485 GHz	–	-18	–	dB	3	
Serial Output Intrinsic Jitter	t_{OJ}	Pseudorandom and SMPTE Colour Bars HD signal	–	50	95	ps	4,6	
	t_{OJ}	Pseudorandom and SMPTE Colour Bars SD signal	–	200	400	ps	5	
GSPI								
GSPI Input Clock Frequency	f_{SCLK}		–	–	80	MHz	–	
GSPI Input Clock Duty Cycle	DC_{SCLK}	50% levels +3.3V or +1.8V operation	40	50	60	%	–	
GSPI Input Data Setup Time	–		1.5	–	–	ns	–	
GSPI Input Data Hold Time	–		1.5	–	–	ns	–	
GSPI Output Data Hold Time	–	15pF load	1.5	–	–	ns	–	
\overline{CS} low before SCLK rising edge	t_0	50% levels +3.3V or +1.8V operation	1.5	–	–	ns	–	
Time between end of command word (or data in Auto-Increment mode) and the first SCLK of the following data word - write cycle	t_4	50% levels +3.3V or +1.8V operation	PCLK (MHz)		–	–	ns	–
			unlocked	445				
			13.5	74.2				
			27.0	37.1				
			74.25	13.5				
			148.5	6.7				
Time between end of command word (or data in Auto-Increment mode) and the first SCLK of the following data word - read cycle	t_5	50% levels +3.3V or +1.8V operation	PCLK (MHz)		–	–	ns	–
			unlocked	1187				
			13.5	297				
			27.0	148.4				
			74.25	53.9				
			148.5	27				

Table 2-4: AC Electrical Characteristics (Continued)

$V_{CC} = +3.3V \pm 5\%$, $T_A = -20^{\circ}C$ to $+85^{\circ}C$, unless otherwise shown

Parameter	Symbol	Conditions	Min		Typ	Max	Units	Notes
\overline{CS} high after SCLK falling edge	t_7	50% levels +3.3V or +1.8V operation	PCLK (MHz)	ns				
			unlocked	445				
			13.5	74.2	-	-	ns	-
			27.0	37.1				
			74.25	13.5				
			148.5	6.7				

Notes:

1. Input setup and hold time is dependent on the rise and fall time on the parallel input. Parallel clock and data with rise time or fall time greater than 500ps require larger setup and hold times.
2. Single Ended into 75 Ω external load.
3. ORL depends on board design.
4. Alignment Jitter = measured from 100kHz to serial data rate/10.
5. Alignment Jitter = measured from 1kHz to 27MHz.
6. This is the maximum jitter for a BER of 10-12. The equivalent jitter value as per RP184 is 40ps max.

3. Input/Output Circuits

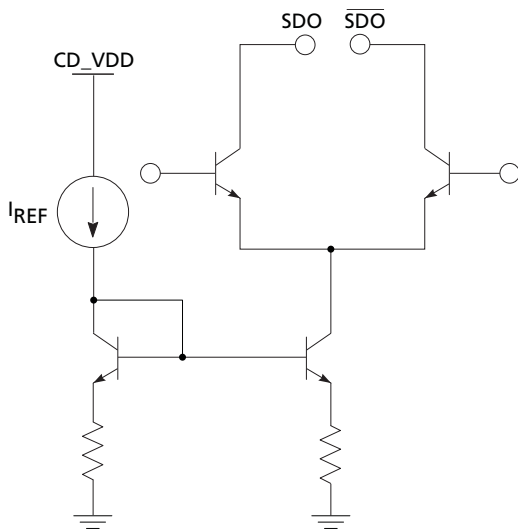

Figure 3-1: Differential Output Stage (SDO/SDO-bar)

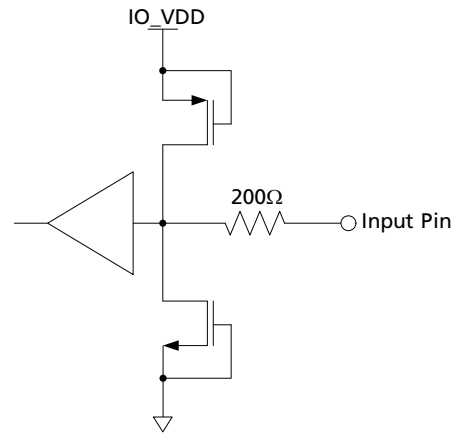

Figure 3-2: Digital Input Pin (20bit/10bit, ANC_BLANK, DETECT_TRS, DVB_ASI, RATE_SEL, SMPTE_BYPASS, TIM_861, F/DE, H/HSYNC, PCLK, V/VSYNC)

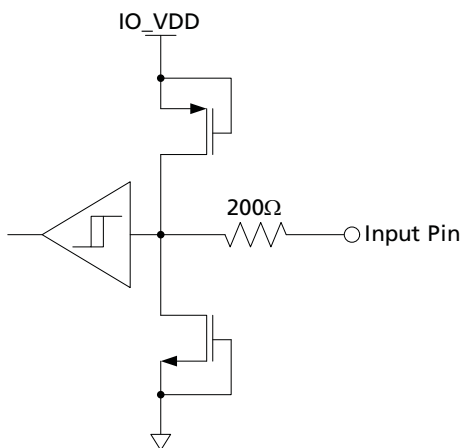

Figure 3-3: Digital Input Pin with Schmitt Trigger (RESET)

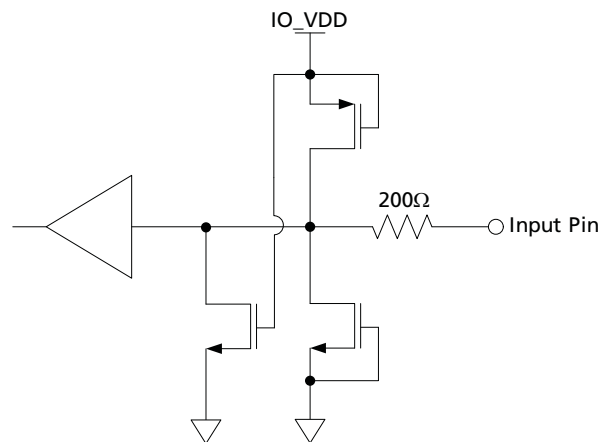

Figure 3-4: Digital Input Pin with weak pull-down - maximum pull-down current <math>< 110\mu\text{A}</math> (JTAG/HOST, STANDBY, SCLK_TCK, SDIN_TDI, TCK, TDI)

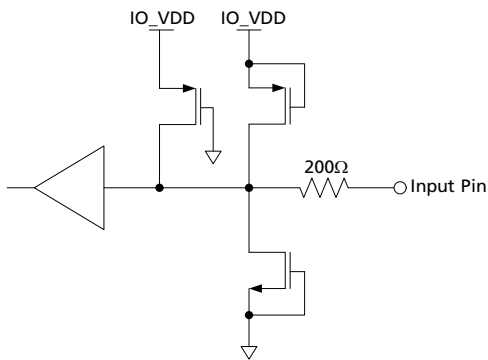

Figure 3-5: Digital Input Pin with weak pull-up - maximum pull-up current <math>< 110\mu\text{A}</math> (ACLK1, ACLK2, AIN_7/8, AIN_5/6, AIN_3/4, AIN_1/2, CS_TMS, GRP1_EN/DIS, GRP2_EN/DIS, IOPROC_EN/DIS, SDO_EN/DIS, TMS, WCLK1, WCLK2)

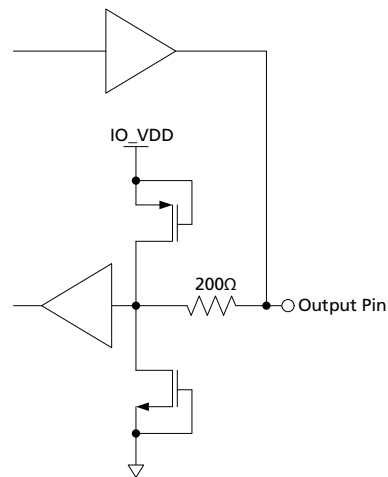

Figure 3-6: Bidirectional Digital Input/Output Pin with programmable drive strength. These pins are configured to input at all times except in test mode. (DIN0, DIN2, DIN3, DIN4, DIN5, DIN6, DIN7, DIN8, DIN9, DIN10, DIN11, DIN12, DIN13, DIN14, DIN15, DIN16, DIN17, DIN18, DIN19, DIN1)

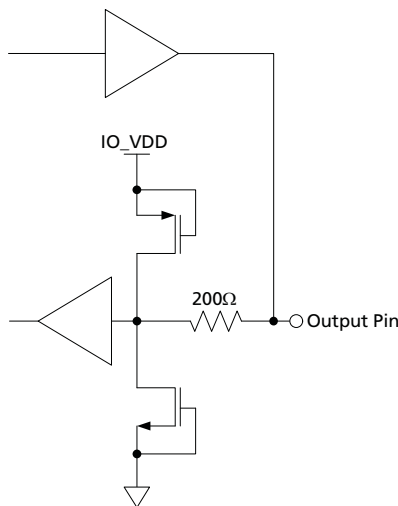

Figure 3-7: Bidirectional Digital Input/Output Pin with programmable drive strength. These pins are configured to output at all times except in reset mode. (LOCKED, AUDIO_INT, SDOUT_TDO, TDO)

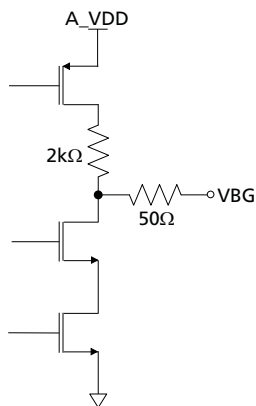

Figure 3-8: VBG

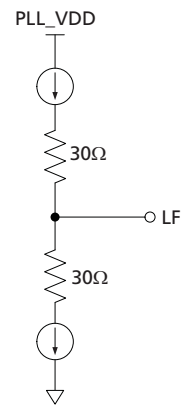

Figure 3-9: Loop Filter