



Chipsmall Limited consists of a professional team with an average of over 10 year of expertise in the distribution of electronic components. Based in Hongkong, we have already established firm and mutual-benefit business relationships with customers from,Europe,America and south Asia,supplying obsolete and hard-to-find components to meet their specific needs.

With the principle of “Quality Parts,Customers Priority,Honest Operation,and Considerate Service”,our business mainly focus on the distribution of electronic components. Line cards we deal with include Microchip,ALPS,ROHM,Xilinx,Pulse,ON,Everlight and Freescale. Main products comprise IC,Modules,Potentiometer,IC Socket,Relay,Connector.Our parts cover such applications as commercial,industrial, and automotives areas.

We are looking forward to setting up business relationship with you and hope to provide you with the best service and solution. Let us make a better world for our industry!



Contact us

Tel: +86-755-8981 8866 Fax: +86-755-8427 6832

Email & Skype: info@chipsmall.com Web: www.chipsmall.com

Address: A1208, Overseas Decoration Building, #122 Zhenhua RD., Futian, Shenzhen, China





3Gb/s, HD, SD SDI Receiver, with Integrated Adaptive Cable Equalizer complete with SMPTE Audio and Video Processing

Key Features

- Operation at 2.97Gb/s, 2.97/1.001Gb/s, 1.485Gb/s, 1.485/1.001Gb/s and 270Mb/s
- Supports SMPTE 425M (Level A and Level B), SMPTE 424M, SMPTE 292M, SMPTE 259M-C and DVB-ASI
- Integrated adaptive cable equalizer
- Typical equalized length of Belden 1694A cable:
 - ♦ 150m at 2.97Gb/s
 - ♦ 250m at 1.485Gb/s
 - ♦ 480m at 270Mb/s
- Integrated Reclocker with low phase noise, integrated VCO
- Serial digital reclocked, or non-reclocked output
- Integrated audio de-embedder for 8 channels of 48kHz audio
- Integrated audio clock generator
- Ancillary data extraction
- Optional conversion from SMPTE 425M Level B to Level A for 1080p 50/60 4:2:2 10-bit
- Parallel data bus selectable as either 20-bit or 10-bit
- Comprehensive error detection and correction features
- Output H, V, F or CEA 861 Timing Signals
- 1.2V digital core power supply, 1.2V and 3.3V analog power supplies, and selectable 1.8V or 3.3V I/O power supply
- GSPI Host Interface
- -20°C to +85°C operating temperature range
- Low power operation (typically 545mW)
- Small 11mm x 11mm 100-ball BGA package
- Pb-free and ROHS compliant

Applications

Application: Single Link (3G-SDI) to Dual Link (HD-SDI) Converter

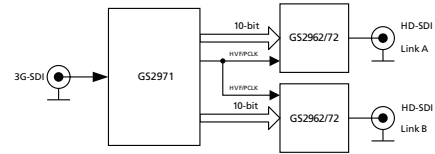

Application: 1080p50/60 Monitor

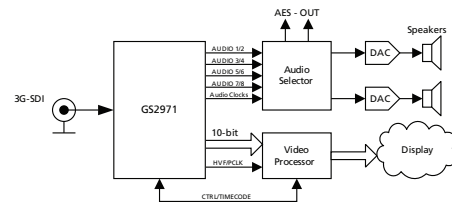

Application: Multi-format Downconverter

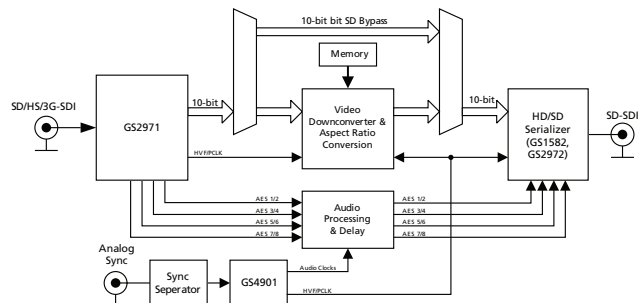

Errata

Refer to Errata document entitled **GS2970/GS2971 Errata** for this device (document number 53092).

Application: Multi-input Video Monitoring System

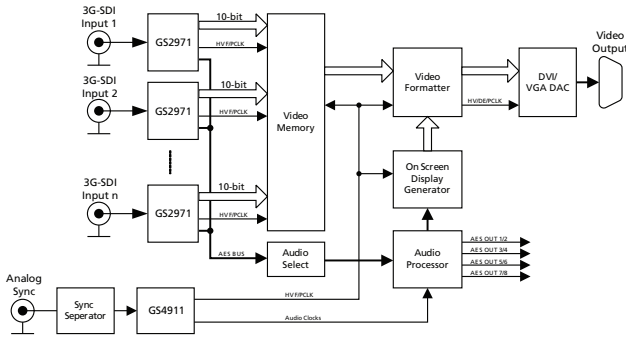

Application: Multi-format Audio De-embedder Module

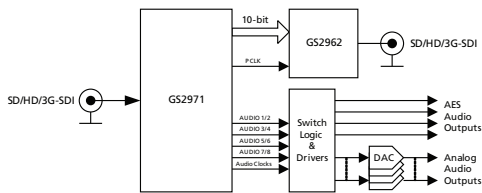

Application: Multi-format Digital VTR/Video Server

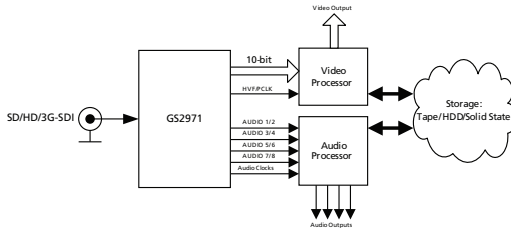

Description

The GS2971 is a multi-rate SDI integrated Receiver which includes complete SMPTE processing, as per SMPTE 425M, 292M and SMPTE 259M-C. The SMPTE processing features can be bypassed to support signals with other coding schemes.

The GS2971 integrates Gennum's adaptive cable equalizer technology, achieving unprecedented cable lengths and jitter tolerance. It features DC restoration to compensate for the DC content of SMPTE pathological signals.

The device features an Integrated Reclocker with an internal VCO and a wide Input Jitter Tolerance (IJT) of 0.7UI.

A serial digital loop-through output is provided, which can be configured to output either reclocked or non-reclocked serial digital data. The serial digital output can be connected to an external cable driver.

The device operates in one of four basic modes: SMPTE mode, DVB-ASI mode, Data-Through mode or Standby mode.

In SMPTE mode (the default operating mode), the GS2971 performs full SMPTE processing, and features a number of data integrity checks and measurement capabilities.

The device also supports ancillary data extraction, and can provide entire ancillary data packets through host-accessible registers. It also provides a variety of other packet detection and error handling features. All of these processing features are optional, and may be individually enabled or disabled through register programming.

Both SMPTE 425M Level A and Level B inputs are supported with optional conversion from Level B to Level A for 1080p 50/59.94/60 4:2:2 10-bit inputs.

In DVB-ASI mode, sync word detection, alignment and 8b/10b decoding is applied to the received data stream.

In Data-Through mode all forms of SMPTE and DVB-ASI processing are disabled, and the device can be used as a simple serial to parallel converter.

The device can also operate in a lower power Standby mode. In this mode, no signal processing is carried out and the parallel output is held static.

Parallel data outputs are provided in 20-bit or 10-bit format for 3Gb/s, HD and SD video rates, with a variety of mapping options. As such, this parallel bus can interface directly with video processor ICs, and output data can be multiplexed onto 10 bits for a low pin count interface.

Up to eight channels (two audio groups) of serial digital audio may be extracted from the video data stream, in accordance with SMPTE 272M-C and SMPTE 299M.

The output audio formats supported by the device include AES/EBU and I²S, and two other industry standard serial digital formats. A variety of audio processing features are provided to ease implementation. Audio clocks are internally generated and provided by the device.

Functional Block Diagram

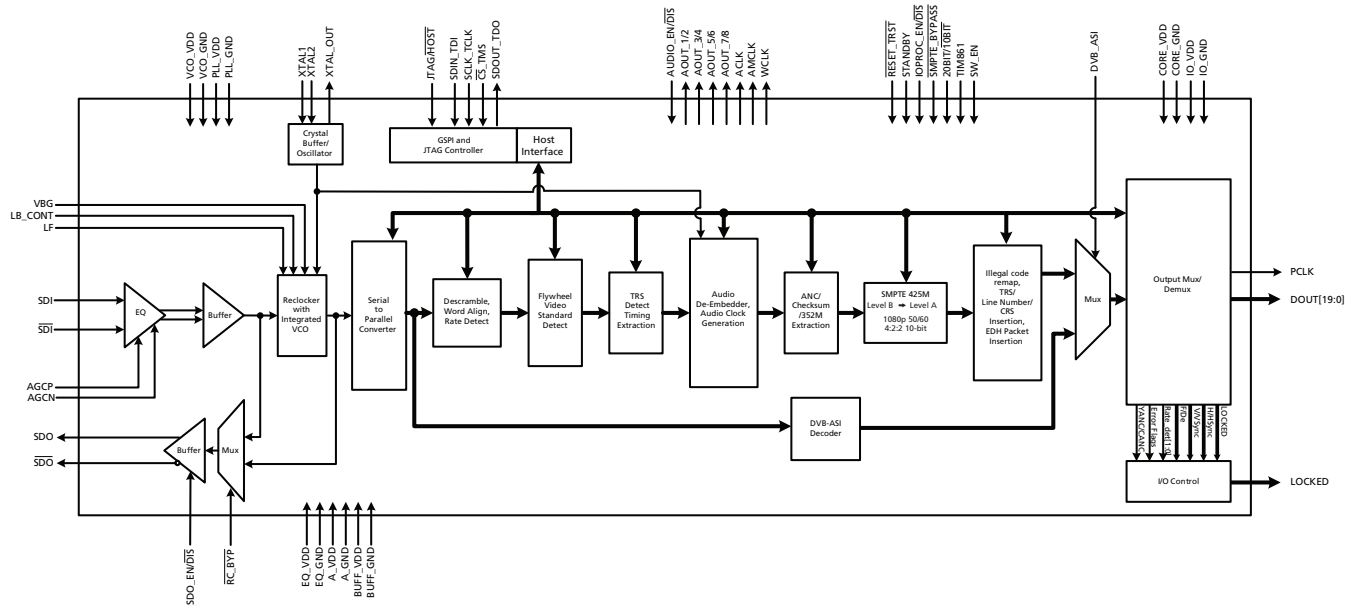

GS2971 Functional Block Diagram

Revision History

Version	ECR	PCN	Date	Changes and/or Modifications
2	158468	–	September 2012	Changes throughout the document.
1	153143	53865	November 2009	Added reference to GS2970/GS2971 Errata (document number 53092). Converted to Data Sheet.
0	152386	–	September 2009	Added Maximum Power numbers to Table 2-3: DC Electrical Characteristics .
C	151887	–	June 2009	Conversion to Preliminary Data Sheet. Corrections to Timing Diagrams in Figure 4-5 , Figure 4-6 and Figure 4-7 . Clarification to Section 4.18.8 . Updates to all sections.
B	151698	–	April 2009	Updated equalized cable lengths and power numbers in Key Features , Table 2-4: AC Electrical Characteristics and Section 4.3.1 .
A	146466	–	February 2009	New Document.

Contents

Key Features	1
Errata.....	1
Applications.....	1
Description.....	2
Functional Block Diagram	3
Revision History	3
1. Pin Out.....	9
1.1 Pin Assignment	9
1.2 Pin Descriptions	9
2. Electrical Characteristics	17
2.1 Absolute Maximum Ratings	17
2.2 Recommended Operating Conditions	17
2.3 DC Electrical Characteristics	18
2.4 AC Electrical Characteristics	20
3. Input/Output Circuits	26
4. Detailed Description.....	29
4.1 Functional Overview	29
4.2 SMPTE 425M Mapping - 3G Level A and Level B Formats	30
4.2.1 Level A Mapping.....	30
4.2.2 Level B Mapping	30
4.3 Serial Digital Input	31
4.3.1 Integrated Adaptive Cable Equalizer.....	31
4.4 Serial Digital Loop-Through Output	32
4.5 Serial Digital Reclocker	33
4.5.1 PLL Loop Bandwidth	33
4.6 External Crystal/Reference Clock	34
4.7 Lock Detect	35
4.7.1 Asynchronous Lock	35
4.7.2 Signal Interruption	36
4.8 SMPTE Functionality	36
4.8.1 Descrambling and Word Alignment	36
4.9 Parallel Data Outputs	37
4.9.1 Parallel Data Bus Buffers.....	37
4.9.2 Parallel Output in SMPTE Mode	40
4.9.3 Parallel Output in DVB-ASI Mode	40
4.9.4 Parallel Output in Data-Through Mode	41
4.9.5 Parallel Output Clock (PCLK).....	41
4.9.6 DDR Parallel Clock Timing	42
4.10 Timing Signal Generator	43
4.10.1 Manual Switch Line Lock Handling	44
4.10.2 Automatic Switch Line Lock Handling	45
4.10.3 Switch Line Lock Handling During Level B to Level A Conversion	45
4.11 Programmable Multi-function Outputs	48
4.12 H:V:F Timing Signal Generation	49

4.12.1 CEA-861 Timing Generation	51
4.13 Automatic Video Standards Detection	59
4.14 Data Format Detection & Indication	62
4.15 EDH Detection	63
4.15.1 EDH Packet Detection	63
4.15.2 EDH Flag Detection	63
4.16 Video Signal Error Detection & Indication	64
4.16.1 TRS Error Detection	65
4.16.2 Line Based CRC Error Detection	66
4.16.3 EDH CRC Error Detection.....	66
4.16.4 HD & 3G Line Number Error Detection	66
4.17 Ancillary Data Detection & Indication	67
4.17.1 Programmable Ancillary Data Detection.....	68
4.17.2 SMPTE 352M Payload Identifier	69
4.17.3 Ancillary Data Checksum Error	70
4.17.4 Video Standard Error	71
4.18 Signal Processing	72
4.18.1 TRS Correction & Insertion.....	73
4.18.2 Line Based CRC Correction & Insertion	73
4.18.3 Line Number Error Correction & Insertion	73
4.18.4 ANC Data Checksum Error Correction & Insertion	73
4.18.5 EDH CRC Correction & Insertion	73
4.18.6 Illegal Word Re-mapping	74
4.18.7 TRS and Ancillary Data Preamble Remapping.....	74
4.18.8 Ancillary Data Extraction.....	74
4.18.9 Level B to Level A Conversion	78
4.19 Audio De-embedder	79
4.19.1 Serial Audio Data I/O Signals.....	79
4.19.2 Serial Audio Data Format Support	81
4.19.3 Audio Processing.....	85
4.19.4 Error Reporting	91
4.20 GSPI - HOST Interface	92
4.20.1 Command Word Description	92
4.20.2 Data Read or Write Access.....	93
4.20.3 GSPI Timing.....	94
4.21 Host Interface Register Maps	96
4.21.1 Video Core Registers.....	96
4.21.2 SD Audio Core Registers	109
4.21.3 HD and 3G Audio Core Registers.....	124
4.22 JTAG Test Operation	139
4.23 Device Power-up	141
4.24 Device Reset	141
4.25 Standby Mode	141
5. Application Reference Design	142
5.1 High Gain Adaptive Cable Equalizers	142
5.2 PCB Layout	142
5.3 Typical Application Circuit	143

6. References & Relevant Standards	144
7. Package & Ordering Information	145
7.1 Package Dimensions	145
7.2 Packaging Data	146
7.3 Marking Diagram	146
7.4 Solder Reflow Profiles	147
7.5 Ordering Information	147

List of Figures

Figure 3-1: Digital Input Pin with Schmitt Trigger	26
Figure 3-2: Bidirectional Digital Input/Output Pin.....	26
Figure 3-3: Bidirectional Digital Input/Output Pin with programmable drive strength.....	27
Figure 3-4: XTAL1/XTAL2/XTAL-OUT	27
Figure 3-5: VBG	27
Figure 3-6: LB_CONT	28
Figure 3-7: Loop Filter	28
Figure 3-8: SDO/ $\overline{\text{SDO}}$	28
Figure 3-9: Equalizer Input Equivalent Circuit	28
Figure 4-1: Level A Mapping	30
Figure 4-2: Level B Mapping	31
Figure 4-3: GS2971 Integrated EQ Block Diagram	32
Figure 4-4: 27MHz Clock Sources	34
Figure 4-5: PCLK to Data and Control Signal Output Timing - SDR Mode 1	37
Figure 4-6: PCLK to Data and Control Signal Output Timing - SDR Mode 2	38
Figure 4-7: PCLK to Data and Control Signal Output Timing - DDR Mode	39
Figure 4-8: DDR Video Interface	42
Figure 4-9: Delay Adjustment Ranges	43
Figure 4-10: Switch Line Locking on a Non-Standard Switch Line	44
Figure 4-11: H:V:F Output Timing - 3G Level A and HDTV 20-bit Mode	49
Figure 4-12: H:V:F Output Timing - 3G Level A and HDTV 10-bit Mode 3G Level B 20-bit Mode, each 10-bit stream	49
Figure 4-13: H:V:F Output Timing - 3G Level B 10-bit Mode	50
Figure 4-14: H:V:F Output Timing - HD 20-bit Output Mode	50
Figure 4-15: H:V:F Output Timing - HD 10-bit Output Mode	50
Figure 4-16: H:V:F Output Timing - SD 20-bit Output Mode	50
Figure 4-17: H:V:F Output Timing - SD 10-bit Output Mode	50
Figure 4-18: H:V:DE Output Timing 1280 x 720p @ 59.94/60 (Format 4)	52
Figure 4-19: H:V:DE Output Timing 1920 x 1080i @ 59.94/60 (Format 5)	53
Figure 4-20: H:V:DE Output Timing 720 (1440) x 480i @ 59.94/60 (Format 6&7)	54
Figure 4-21: H:V:DE Output Timing 1280 x 720p @ 50 (Format 19)	54
Figure 4-22: H:V:DE Output Timing 1920 x 1080i @ 50 (Format 20)	55
Figure 4-23: H:V:DE Output Timing 720 (1440) x 576 @ 50 (Format 21 & 22)	56
Figure 4-24: H:V:DE Output Timing 1920 x 1080p @ 59.94/60 (Format 16)	56
Figure 4-25: H:V:DE Output Timing 1920 x 1080p @ 50 (Format 31)	57
Figure 4-26: H:V:DE Output Timing 1920 x 1080p @ 23.94/24 (Format 32)	57
Figure 4-27: H:V:DE Output Timing 1920 x 1080p @ 25 (Format 33)	58
Figure 4-28: H:V:DE Output Timing 1920 x 1080p @ 29.97/30 (Format 34)	58
Figure 4-29: Y/1ANC and C/2ANC Signal Timing	68
Figure 4-30: Ancillary Data Extraction - Step A	75
Figure 4-31: Ancillary Data Extraction - Step B	76

Figure 4-32: Ancillary Data Extraction - Step C	76
Figure 4-33: Ancillary Data Extraction - Step D	77
Figure 4-34: ACLK to Data Signal Output Timing	80
Figure 4-35: I ² S Audio Output Format	81
Figure 4-36: AES/EBU Audio Output Format	81
Figure 4-37: Serial Audio, Left Justified, MSB First	82
Figure 4-38: Serial Audio, Left Justified, LSB First	82
Figure 4-39: Serial Audio, Right Justified, MSB First	82
Figure 4-40: Serial Audio, Right Justified, LSB First	82
Figure 4-41: AES/EBU Audio Output to Bit Clock Timing	82
Figure 4-42: ECC 24-bit Array and Examples	85
Figure 4-43: Sample Distribution over 5 Video Frames (525-line Systems)	86
Figure 4-44: Audio Buffer After Initial 26 Sample Write	87
Figure 4-45: Audio Buffer Pointer Boundary Checking	87
Figure 4-46: GSPI Application Interface Connection	92
Figure 4-47: Command Word Format	92
Figure 4-48: Data Word Format	93
Figure 4-49: Write Mode	94
Figure 4-50: Read Mode	94
Figure 4-51: GSPI Time Delay	94
Figure 4-52: In-Circuit JTAG	140
Figure 4-53: System JTAG	140
Figure 4-54: Reset Pulse	141
Figure 7-55: Pb-free Solder Reflow Profile	147

List of Tables

Table 1-1: Pin Descriptions	9
Table 2-1: Absolute Maximum Ratings	17
Table 2-2: Recommended Operating Conditions	17
Table 2-3: DC Electrical Characteristics	18
Table 2-4: AC Electrical Characteristics	20
Table 4-1: Serial Digital Output	32
Table 4-2: PLL Loop Bandwidth	33
Table 4-3: Input Clock Requirements	34
Table 4-4: Lock Detect Conditions	35
Table 4-5: GS2971 Output Video Data Format Selections	39
Table 4-6: GS2971 PCLK Output Rates	41
Table 4-7: Switch Line Position for Digital Systems	46
Table 4-8: Output Signals Available on Programmable Multi-Function Pins	48
Table 4-9: Supported CEA-861 Formats	51
Table 4-10: CEA861 Timing Formats	52
Table 4-11: Supported Video Standard Codes	59
Table 4-12: Data Format Register Codes	62
Table 4-13: Error Status Register and Error Mask Register	65
Table 4-14: SMPTE 352M Packet Data	70
Table 4-15: IOPROC_DISABLE Register Bits	72
Table 4-16: Serial Audio Pin Descriptions	79
Table 4-17: Audio Output Formats	81
Table 4-18: Audio Data Packet Detect Register	83
Table 4-19: Audio Group DID Host Interface Settings	84

Table 4-20: Audio Data and Control Packet DID Setting Register	84
Table 4-21: Audio Buffer Pointer Offset Settings	88
Table 4-22: Audio Channel Mapping Codes	88
Table 4-23: Audio Sample Word Lengths	89
Table 4-24: Audio Channel Status Information Registers	90
Table 4-25: Audio Channel Status Block for Regenerate Mode Default Settings	90
Table 4-26: Audio Mute Control Bits	91
Table 4-27: GSPI Time Delay	94
Table 4-28: GSPI Timing Parameters (50% levels; 3.3V or 1.8V operation)	95
Table 4-29: Video Core Configuration and Status Registers.....	96
Table 4-30: SD Audio Core Configuration and Status Registers.....	109
Table 4-31: HD and 3G Audio Core Configuration and Status Registers	124
Table 4-32: ANC Extraction FIFO Access Registers.....	139
Table 7-1: Packaging Data.....	146

1. Pin Out

1.1 Pin Assignment

	1	2	3	4	5	6	7	8	9	10
A	VBG	LF	LB_CONT	VCO_VDD	STAT0	STAT1	IO_VDD	PCLK	DOUT18	DOUT17
B	A_VDD	PLL_VDD	RSV	VCO_GND	STAT2	STAT3	IO_GND	DOUT19	DOUT16	DOUT15
C	SDI	A_GND	PLL_VDD	PLL_VDD	STAT4	STAT5	$\overline{\text{RESET_TRST}}$	DOUT12	DOUT14	DOUT13
D	$\overline{\text{SDI}}$	A_GND	A_GND	PLL_GND	CORE_GND	CORE_VDD	SW_EN	JTAG/HOST	IO_GND	IO_VDD
E	EQ_VDD	EQ_GND	A_GND	PLL_GND	CORE_GND	CORE_VDD	SDOUT_TDO	SDIN_TDI	DOUT10	DOUT11
F	AGCP	RSV	A_GND	PLL_GND	CORE_GND	CORE_VDD	$\overline{\text{CS_TMS}}$	SCLK_TCK	DOUT8	DOUT9
G	AGCN	A_GND	$\overline{\text{RC_BYP}}$	CORE_GND	CORE_GND	CORE_VDD	$\overline{\text{SMPTE_BYPASS}}$	DVB_ASI	IO_GND	IO_VDD
H	BUFF_VDD	BUFF_GND	AUDIO_EN/DIS	WCLK	TIM_861	XTAL_OUT	20bit/10bit	IOPROC_EN/DIS	DOUT6	DOUT7
J	SDO	SDO_EN/DIS	AOUT_1/2	ACLK	AOUT_5/6	XTAL2	IO_GND	DOUT1	DOUT4	DOUT5
K	$\overline{\text{SDO}}$	STANDBY	AOUT_3/4	AMCLK	AOUT_7/8	XTAL1	IO_VDD	DOUT0	DOUT2	DOUT3

1.2 Pin Descriptions

Table 1-1: Pin Descriptions

Pin Number	Name	Timing	Type	Description
A1	VBG		Analog Input	Band Gap voltage filter connection.
A2	LF		Analog Input	Loop Filter component connection.
A3	LB_CONT		Analog Input	Connection for loop bandwidth control resistor.
A4	VCO_VDD		Input Power	POWER pin for the VCO. Connect to a 1.2V±5% analog supply followed by a RC filter (see 5. Application Reference Design). A 105Ω 1% resistor must be used in the RC filter circuit. VCO_VDD is nominally 0.7V.

Table 1-1: Pin Descriptions (Continued)

Pin Number	Name	Timing	Type	Description																												
A5, A6, B5, B6, C5, C6	STAT[0:5]		Output	<p>MULTI-FUNCTIONAL OUTPUT PORT.</p> <p>Please refer to the Output Logic parameters in the DC Electrical Characteristics table for logic level threshold and compatibility.</p> <p>Each of the STAT [0:5] pins can be configured individually to output one of the following signals:</p> <table border="1"> <thead> <tr> <th>Signal</th> <th>Default</th> </tr> </thead> <tbody> <tr> <td>H/HSYNC</td> <td>STAT0</td> </tr> <tr> <td>V/VSYNC</td> <td>STAT1</td> </tr> <tr> <td>F/DE</td> <td>STAT2</td> </tr> <tr> <td>LOCKED</td> <td>STAT3</td> </tr> <tr> <td>Y/1ANC</td> <td>STAT4</td> </tr> <tr> <td>C/2ANC</td> <td>–</td> </tr> <tr> <td>DATA ERROR</td> <td>STAT5</td> </tr> <tr> <td>VIDEO ERROR</td> <td>–</td> </tr> <tr> <td>AUDIO ERROR</td> <td>–</td> </tr> <tr> <td>EDH DETECTED</td> <td>–</td> </tr> <tr> <td>CARRIER DETECT</td> <td>–</td> </tr> <tr> <td>RATE_DET0</td> <td>–</td> </tr> <tr> <td>RATE_DET1</td> <td>–</td> </tr> </tbody> </table>	Signal	Default	H/HSYNC	STAT0	V/VSYNC	STAT1	F/DE	STAT2	LOCKED	STAT3	Y/1ANC	STAT4	C/2ANC	–	DATA ERROR	STAT5	VIDEO ERROR	–	AUDIO ERROR	–	EDH DETECTED	–	CARRIER DETECT	–	RATE_DET0	–	RATE_DET1	–
Signal	Default																															
H/HSYNC	STAT0																															
V/VSYNC	STAT1																															
F/DE	STAT2																															
LOCKED	STAT3																															
Y/1ANC	STAT4																															
C/2ANC	–																															
DATA ERROR	STAT5																															
VIDEO ERROR	–																															
AUDIO ERROR	–																															
EDH DETECTED	–																															
CARRIER DETECT	–																															
RATE_DET0	–																															
RATE_DET1	–																															
A7, D10, G10, K7	IO_VDD		Input Power	POWER connection for digital I/O. Connect to 3.3V or 1.8V DC digital.																												
A8	PCLK		Output	<p>PARALLEL DATA BUS CLOCK</p> <p>Please refer to the Output Logic parameters in the DC Electrical Characteristics table for logic level threshold and compatibility.</p> <table border="1"> <tbody> <tr> <td>3G 10-bit or 20-bit mode</td> <td>PCLK @ 148.5 or 148.5/1.001MHz</td> </tr> <tr> <td>HD 10-bit mode</td> <td>PCLK @ 148.5 or 148.5/1.001MHz</td> </tr> <tr> <td>HD 20-bit mode</td> <td>PCLK @ 74.25 or 74.25/1.001MHz</td> </tr> <tr> <td>SD 10-bit mode</td> <td>PCLK @ 27MHz</td> </tr> <tr> <td>SD 20-bit mode</td> <td>PCLK @ 13.5MHz</td> </tr> </tbody> </table>	3G 10-bit or 20-bit mode	PCLK @ 148.5 or 148.5/1.001MHz	HD 10-bit mode	PCLK @ 148.5 or 148.5/1.001MHz	HD 20-bit mode	PCLK @ 74.25 or 74.25/1.001MHz	SD 10-bit mode	PCLK @ 27MHz	SD 20-bit mode	PCLK @ 13.5MHz																		
3G 10-bit or 20-bit mode	PCLK @ 148.5 or 148.5/1.001MHz																															
HD 10-bit mode	PCLK @ 148.5 or 148.5/1.001MHz																															
HD 20-bit mode	PCLK @ 74.25 or 74.25/1.001MHz																															
SD 10-bit mode	PCLK @ 27MHz																															
SD 20-bit mode	PCLK @ 13.5MHz																															

Table 1-1: Pin Descriptions (Continued)

Pin Number	Name	Timing	Type	Description
A9, A10, B8, B9, B10, C8, C9, C10, E9, E10	DOUT18, 17, 19, 16, 15, 12, 14, 13, 10, 11		Output	<p>PARALLEL DATA BUS</p> <p>Please refer to the Output Logic parameters in the DC Electrical Characteristics table for logic level threshold and compatibility.</p> <hr/> <p>20-bit mode 20bit/10bit = HIGH</p> <p>SMPTE mode ($\overline{\text{SMPTE_BYPASS}} = \text{HIGH}$ and $\text{DVB_ASI} = \text{LOW}$): Luma data output for SD and HD data rates; Data Stream 1 for 3G data rate</p> <p>DVB-ASI mode ($\overline{\text{SMPTE_BYPASS}} = \text{LOW}$ and $\text{DVB_ASI} = \text{HIGH}$): Not defined</p> <p>Data-Through mode ($\overline{\text{SMPTE_BYPASS}} = \text{LOW}$ and $\text{DVB_ASI} = \text{LOW}$): Data output</p> <hr/> <p>10-bit mode 20bit/10bit = LOW</p> <p>SMPTE mode ($\overline{\text{SMPTE_BYPASS}} = \text{HIGH}$ and $\text{DVB_ASI} = \text{LOW}$): Multiplexed Luma/Chroma data output for SD and HD data rates; Multiplexed Data Stream 1&2 for 3G data rate</p> <p>DVB-ASI mode ($\overline{\text{SMPTE_BYPASS}} = \text{LOW}$ and $\text{DVB_ASI} = \text{HIGH}$): 8b/10b decoded DVB-ASI data</p> <p>Data-Through mode ($\overline{\text{SMPTE_BYPASS}} = \text{LOW}$ and $\text{DVB_ASI} = \text{LOW}$): Data output</p>
B1	A_VDD		Input Power	POWER pin for analog circuitry. Connect to 3.3V DC analog.
B2, C3, C4	PLL_VDD		Input Power	POWER pins for the Reclocker PLL. Connect to 1.2V DC analog.
B3, F2	RSV			These pins must be left unconnected.
B4	VCO_GND		Input Power	GND pin for the VCO. Connect to analog GND.
B7, D9, G9, J7	IO_GND		Input Power	GND connection for digital I/O. Connect to digital GND.
C1, D1	SDI, $\overline{\text{SDI}}$		Analog Input	Serial Digital Differential Input.
C2, D2, D3, E3, F3, G2	A_GND		Input Power	GND pins for sensitive analog circuitry. Connect to analog GND.

Table 1-1: Pin Descriptions (Continued)

Pin Number	Name	Timing	Type	Description
C7	$\overline{\text{RESET_TRST}}$		Input	<p>CONTROL SIGNAL INPUT</p> <p>Please refer to the Input Logic parameters in the DC Electrical Characteristics table for logic level threshold and compatibility.</p> <p>Used to reset the internal operating conditions to default settings and to reset the JTAG sequence.</p> <p>Normal mode ($\text{JTAG}/\overline{\text{HOST}} = \text{LOW}$):</p> <p>When LOW, all functional blocks are set to default conditions and all digital output signals become high impedance.</p> <p>When HIGH, normal operation of the device resumes.</p> <p>JTAG test mode ($\text{JTAG}/\overline{\text{HOST}} = \text{HIGH}$):</p> <p>When LOW, all functional blocks are set to default and the JTAG test sequence is reset.</p> <p>When HIGH, normal operation of the JTAG test sequence resumes after $\overline{\text{RESET_TRST}}$ is de-asserted.</p>
D4, E4, F4	PLL_GND		Input Power	GND pins for the Reclocker PLL. Connect to analog GND.
D5, E5, F5, G4, G5	CORE_GND		Input Power	GND connection for device core. Connect to digital GND.
D6, E6, F6, G6	CORE_VDD		Input Power	POWER connection for device core. Connect to 1.2V DC digital.
D7	SW_EN		Input	<p>CONTROL SIGNAL INPUT</p> <p>Please refer to the Input Logic parameters in the DC Electrical Characteristics table for logic level threshold and compatibility.</p> <p>Used to enable switch-line locking, as described in Section 4.10.1.</p>
D8	$\text{JTAG}/\overline{\text{HOST}}$		Input	<p>CONTROL SIGNAL INPUT</p> <p>Please refer to the Input Logic parameters in the DC Electrical Characteristics table for logic level threshold and compatibility.</p> <p>Used to select JTAG test mode or host interface mode.</p> <p>When $\text{JTAG}/\overline{\text{HOST}}$ is HIGH, the host interface port is configured for JTAG test.</p> <p>When $\text{JTAG}/\overline{\text{HOST}}$ is LOW, normal operation of the host interface port resumes.</p>
E1	EQ_VDD		Input Power	POWER pin for SDI buffer. Connect to 3.3V DC analog.
E2	EQ_GND		Input Power	GND pin for SDI buffer. Connect to analog GND.
E7	SDOUT_TDO		Output	<p>COMMUNICATION SIGNAL OUTPUT</p> <p>Please refer to the Output Logic parameters in the DC Electrical Characteristics table for logic level threshold and compatibility.</p> <p>GSPI serial data output/test data out.</p> <p>In JTAG mode ($\text{JTAG}/\overline{\text{HOST}} = \text{HIGH}$), this pin is used to shift test results from the device.</p> <p>In host interface mode, this pin is used to read status and configuration data from the device.</p> <p>Note: GSPI is slightly different than the SPI. For more details on GSPI, please refer to 4.20 GSPI - HOST Interface.</p>

Table 1-1: Pin Descriptions (Continued)

Pin Number	Name	Timing	Type	Description				
E8	SDIN_TDI		Input	<p>COMMUNICATION SIGNAL INPUT</p> <p>Please refer to the Input Logic parameters in the DC Electrical Characteristics table for logic level threshold and compatibility.</p> <p>GSPI serial data in/test data in.</p> <p>In JTAG mode ($JTAG/\overline{HOST} = \text{HIGH}$), this pin is used to shift test data into the device.</p> <p>In host interface mode, this pin is used to write address and configuration data words into the device.</p>				
F1, G1	AGCP, AGCN			Automatic Gain Control for the equalizer. Attach the AGC capacitor between these pins.				
F7	$\overline{CS_TMS}$		Input	<p>COMMUNICATION SIGNAL INPUT</p> <p>Please refer to the Input Logic parameters in the DC Electrical Characteristics table for logic level threshold and compatibility.</p> <p>Chip select / test mode start.</p> <p>In JTAG mode ($JTAG/\overline{HOST} = \text{HIGH}$), this pin is Test Mode Start, used to control the operation of the JTAG test.</p> <p>In host interface mode ($JTAG/\overline{HOST} = \text{LOW}$), this pin operates as the host interface chip select and is active LOW.</p>				
F8	SCLK_TCK		Input	<p>COMMUNICATION SIGNAL INPUT</p> <p>Please refer to the Input Logic parameters in the DC Electrical Characteristics table for logic level threshold and compatibility.</p> <p>Serial data clock signal.</p> <p>In JTAG mode ($JTAG/\overline{HOST} = \text{HIGH}$), this pin is the JTAG clock.</p> <p>In host interface mode ($JTAG/\overline{HOST} = \text{LOW}$), this pin is the host interface serial bit clock.</p> <p>All JTAG/host interface addresses and data are shifted into/out of the device synchronously with this clock.</p>				
F9, F10, H9, H10, J8, J9, J10, K8, K9, K10	DOUT8, 9, 6, 7, 1, 4, 5, 0, 2, 3		Output	<p>PARALLEL DATA BUS</p> <p>Please refer to the Output Logic parameters in the DC Electrical Characteristics table for logic level threshold and compatibility.</p> <hr/> <table border="0"> <tr> <td style="vertical-align: top;"> <p>20-bit mode 20bit/10bit = HIGH</p> </td> <td style="vertical-align: top;"> <p>SMPTE mode ($\overline{SMPTE_BYPASS} = \text{HIGH}$ and $DVB_ASI = \text{LOW}$): Chroma data output for SD and HD data rates; Data Stream 2 for 3G data rate</p> <p>DVB-ASI mode ($\overline{SMPTE_BYPASS} = \text{LOW}$ and $DVB_ASI = \text{HIGH}$): Not defined</p> <p>Data-Through mode ($\overline{SMPTE_BYPASS} = \text{LOW}$ and $DVB_ASI = \text{LOW}$): Data output</p> </td> </tr> </table> <hr/> <table border="0"> <tr> <td style="vertical-align: top;"> <p>10-bit mode 20bit/10bit = LOW</p> </td> <td style="vertical-align: top;"> <p>Forced LOW</p> </td> </tr> </table>	<p>20-bit mode 20bit/10bit = HIGH</p>	<p>SMPTE mode ($\overline{SMPTE_BYPASS} = \text{HIGH}$ and $DVB_ASI = \text{LOW}$): Chroma data output for SD and HD data rates; Data Stream 2 for 3G data rate</p> <p>DVB-ASI mode ($\overline{SMPTE_BYPASS} = \text{LOW}$ and $DVB_ASI = \text{HIGH}$): Not defined</p> <p>Data-Through mode ($\overline{SMPTE_BYPASS} = \text{LOW}$ and $DVB_ASI = \text{LOW}$): Data output</p>	<p>10-bit mode 20bit/10bit = LOW</p>	<p>Forced LOW</p>
<p>20-bit mode 20bit/10bit = HIGH</p>	<p>SMPTE mode ($\overline{SMPTE_BYPASS} = \text{HIGH}$ and $DVB_ASI = \text{LOW}$): Chroma data output for SD and HD data rates; Data Stream 2 for 3G data rate</p> <p>DVB-ASI mode ($\overline{SMPTE_BYPASS} = \text{LOW}$ and $DVB_ASI = \text{HIGH}$): Not defined</p> <p>Data-Through mode ($\overline{SMPTE_BYPASS} = \text{LOW}$ and $DVB_ASI = \text{LOW}$): Data output</p>							
<p>10-bit mode 20bit/10bit = LOW</p>	<p>Forced LOW</p>							

Table 1-1: Pin Descriptions (Continued)

Pin Number	Name	Timing	Type	Description
G3	$\overline{\text{RC_BYP}}$		Input	<p>CONTROL SIGNAL INPUT</p> <p>Please refer to the Input Logic parameters in the DC Electrical Characteristics table for logic level threshold and compatibility.</p> <p>When this pin is LOW, the serial digital output is the buffered version of the input serial data. When this pin is HIGH, the serial digital output is the reclocked version of the input serial data.</p>
G7	$\overline{\text{SMPTE_BYPASS}}$		Input/Output	<p>CONTROL SIGNAL INPUT/OUTPUT</p> <p>Please refer to the Input/Output Logic parameters in the DC Electrical Characteristics table for logic level threshold and compatibility.</p> <p>Indicates the presence of valid SMPTE data.</p> <p>When the $\text{AUTO}/\overline{\text{MAN}}$ bit in the host interface register is HIGH (Default), this pin is an OUTPUT. $\overline{\text{SMPTE_BYPASS}}$ is HIGH when the device locks to a SMPTE compliant input. $\overline{\text{SMPTE_BYPASS}}$ is LOW under all other conditions.</p> <p>When the $\text{AUTO}/\overline{\text{MAN}}$ bit in the host interface register is LOW, this pin is an INPUT:</p> <p>No SMPTE scrambling takes place, and none of the I/O processing features of the device are available when $\overline{\text{SMPTE_BYPASS}}$ is set LOW.</p> <p>When $\overline{\text{SMPTE_BYPASS}}$ is set HIGH, the device carries out SMPTE scrambling and I/O processing.</p> <p>When $\overline{\text{SMPTE_BYPASS}}$ and DVB_ASI are both set LOW, the device operates in Data-Through mode.</p>
G8	DVB_ASI		Input/Output	<p>CONTROL SIGNAL INPUT</p> <p>Please refer to the Input/Output Logic parameters in the DC Electrical Characteristics table for logic level threshold and compatibility.</p> <p>Used to enable/disable DVB-ASI data extraction in manual mode.</p> <p>When the $\text{AUTO}/\overline{\text{MAN}}$ bit in the host interface is LOW, this pin is an input and when the DVB_ASI pin is set HIGH the device will carry out DVB_ASI data extraction and processing. The $\overline{\text{SMPTE_BYPASS}}$ pin must be set LOW. When $\overline{\text{SMPTE_BYPASS}}$ and DVB_ASI are both set LOW, the device operates in Data-Through mode.</p> <p>When the $\text{AUTO}/\overline{\text{MAN}}$ bit in the host interface is HIGH (default), DVB-ASI is configured as a status output (set LOW), and DVB-ASI input streams are not supported or recognized.</p>
H1	BUFF_VDD		Input Power	<p>POWER pin for the serial digital output 50Ω buffer. Connect to 3.3V DC analog.</p>
H2	BUFF_GND		Input Power	<p>GND pin for the cable driver buffer. Connect to analog GND.</p>
H3	$\text{AUDIO_EN}/\overline{\text{DIS}}$		Input	<p>CONTROL SIGNAL INPUT</p> <p>Please refer to the Input Logic parameters in the DC Electrical Characteristics table for logic level threshold and compatibility.</p> <p>Enables or disables audio extraction.</p>
H4	WCLK		Output	<p>48kHz word clock for Audio.</p> <p>Signal levels are LVCMOS/LVTTL compatible.</p>

Table 1-1: Pin Descriptions (Continued)

Pin Number	Name	Timing	Type	Description
H5	TIM_861		Input	CONTROL SIGNAL INPUT Please refer to the Input Logic parameters in the DC Electrical Characteristics table for logic level threshold and compatibility. Used to select CEA-861 timing mode. When TIM_861 is HIGH, the device outputs CEA 861 timing signals (HSYNC/VSYNC/DE) instead of H:V:F digital timing signals.
H6	XTAL_OUT		Digital Output	Buffered 27MHz crystal output. Can be used to cascade the crystal signal.
H7	20bit/ $\overline{10bit}$		Input	CONTROL SIGNAL INPUT Please refer to the Input Logic parameters in the DC Electrical Characteristics table for logic level threshold and compatibility. Used to select the output bus width. HIGH = 20-bit, LOW = 10-bit.
H8	IOPROC_EN/ \overline{DIS}		Input	CONTROL SIGNAL INPUT Please refer to the Input Logic parameters in the DC Electrical Characteristics table for logic level threshold and compatibility. Used to enable or disable audio and video processing features. When IOPROC_EN is HIGH, the audio and video processing features of the device are enabled. When IOPROC_EN is LOW, the processing features of the device are disabled, and the device is in a low-latency operating mode.
J1, K1	SDO, \overline{SDO}		Output	Serial Data Output Signal. 50Ω CML buffer for interfacing to an external cable driver. Serial digital output signal operating at 2.97Gb/s, 2.97/1.001Gb/s, 1.485Gb/s, 1.485/1.001Gb/s and 270Mb/s.
J2	SDO_EN/ \overline{DIS}		Input	CONTROL SIGNAL INPUT Please refer to the Input Logic parameters in the DC Electrical Characteristics table for logic level threshold and compatibility. Used to enable/disable the serial digital output stage. When SDO_EN/ \overline{DIS} is LOW, the serial digital output signals, SDO and \overline{SDO} , are both pulled HIGH. When SDO_EN/ \overline{DIS} is HIGH, the serial digital output signals, SDO and \overline{SDO} , are enabled.
J3	AOUT_1/2		Output	Serial Audio Output; Channels 1 and 2. Please refer to the Output Logic parameters in the DC Electrical Characteristics table for logic level threshold and compatibility.
J4	ACLK		Output	64fs sample clock for audio. Please refer to the Output Logic parameters in the DC Electrical Characteristics table for logic level threshold and compatibility.
J5	AOUT_5/6		Output	Serial Audio Output; Channels 5 and 6. Please refer to the Output Logic parameters in the DC Electrical Characteristics table for logic level threshold and compatibility.
J6, K6	XTAL2, XTAL1		Analog Input	Input connection for 27MHz crystal.

Table 1-1: Pin Descriptions (Continued)

Pin Number	Name	Timing	Type	Description
K2	STANDBY		Input	<p>CONTROL SIGNAL INPUT</p> <p>Please refer to the Input Logic parameters in the DC Electrical Characteristics table for logic level threshold and compatibility.</p> <p>When this pin is set HIGH, the device is placed in a power-saving mode. No data processing occurs, and the digital I/Os are powered down.</p> <p>In this mode, the serial digital output signals, SDO and \overline{SDO}, are both pulled HIGH.</p>
K3	AOUT_3/4		Output	<p>Serial Audio Output; Channels 3 and 4.</p> <p>Please refer to the Output Logic parameters in the DC Electrical Characteristics table for logic level threshold and compatibility.</p>
K4	AMCLK		Output	<p>Oversampled master clock for audio (128fs, 256fs, 512fs selectable).</p> <p>Please refer to the Output Logic parameters in the DC Electrical Characteristics table for logic level threshold and compatibility.</p>
K5	AOUT_7/8		Output	<p>Serial Audio Output; Channels 7 and 8.</p> <p>Please refer to the Output Logic parameters in the DC Electrical Characteristics table for logic level threshold and compatibility.</p>

2. Electrical Characteristics

2.1 Absolute Maximum Ratings

Table 2-1: Absolute Maximum Ratings

Parameter	Value/Units
Supply Voltage, Digital Core (CORE_VDD)	-0.3V to +1.5V
Supply Voltage, Digital I/O (IO_VDD)	-0.3V to +4.0V
Supply Voltage, Analog 1.2V (PD_VDD, VCO_VDD)	-0.3V to +1.5V
Supply Voltage, Analog 3.3V (EQ_VDD, BUFF_VDD, A_VDD)	-0.3V to +4.0V
Input Voltage Range (digital inputs)	-2.0V to +5.25V
Ambient Operating Temperature (T_A)	$-40^{\circ}\text{C} \leq T_A \leq 95^{\circ}\text{C}$
Storage Temperature (T_{STG})	$-40^{\circ}\text{C} \leq T_{STG} \leq 125^{\circ}\text{C}$
Peak Reflow Temperature (JEDEC J-STD-020C)	260°C
ESD Sensitivity, HBM (JESD22-A114)	2kV

NOTES:

Absolute Maximum Ratings are those values beyond which damage may occur. Functional operation under these conditions or at any other condition beyond those indicated in the AC/DC Electrical Characteristics sections is not implied.

2.2 Recommended Operating Conditions

Table 2-2: Recommended Operating Conditions

Parameter	Symbol	Conditions	Min	Typ	Max	Units	Notes
Operating Temperature Range, Ambient	T_A	–	-20	–	85	°C	–
Supply Voltage, Digital Core	CORE_VDD	–	1.14	1.2	1.26	V	–
Supply Voltage, Digital I/O	IO_VDD	1.8V mode	1.71	1.8	1.89	V	–
		3.3V mode	3.13	3.3	3.47	V	–
Supply Voltage, PLL	PLL_VDD	–	1.14	1.2	1.26	V	–
Supply Voltage, VCO	VCO_VDD	–	–	0.7	–	V	1
Supply Voltage, Analog	A_VDD	–	3.13	3.3	3.47	V	2
Supply Voltage, Serial Digital Input	EQ_VDD	–	3.13	3.3	3.47	V	2
Supply Voltage, CD Buffer	BUFF_VDD	–	3.13	3.3	3.47	V	2

NOTES

1. This is 0.7V rather than 1.2V because there is a voltage drop across an external 105Ω resistor. See [Typical Application Circuit on page 143](#).
2. The 3.3V supplies must track the 3.3V supply of an external CD.

2.3 DC Electrical Characteristics

Table 2-3: DC Electrical Characteristics

Guaranteed over recommended operating conditions unless otherwise noted.

Parameter	Symbol	Conditions	Min	Typ	Max	Units	Notes
System							
+1.2V Supply Current	I_{1V2}	10bit 3G	–	220	265	mA	–
		20bit 3G	–	210	265	mA	–
		10/20bit HD	–	170	220	mA	–
		10/20bit SD	–	140	185	mA	–
		DVB_ASI	–	130	170	mA	–
+1.8V Supply Current	I_{1V8}	10bit 3G	–	37	45	mA	–
		20bit 3G	–	16	20	mA	–
		10/20bit HD	–	15	21	mA	–
		10/20bit SD	–	4	7	mA	–
		DVB_ASI	–	4	6	mA	–
+3.3V Supply Current	I_{3V3}	10bit 3G	–	150	180	mA	–
		20bit 3G	–	115	130	mA	–
		10/20bit HD	–	110	135	mA	–
		10/20bit SD	–	90	100	mA	–
		DVB_ASI	–	90	95	mA	–
Total Device Power (IO_VDD = 1.8V)	P_{1D8}	10bit 3G	–	560	680	mW	–
		20bit 3G	–	525	640	mW	–
		10/20bit HD	–	480	590	mW	–
		10/20bit SD	–	420	520	mW	–
		DVB_ASI	–	410	500	mW	–
		Reset	–	390	–	mW	–
		Standby	–	23	45	mW	–
Total Device Power (IO_VDD = 3.3V)	P_{3D3}	10bit 3G	–	750	930	mW	–
		20bit 3G	–	620	760	mW	–
		10/20bit HD	–	570	730	mW	–
		10/20bit SD	–	460	560	mW	–
		DVB_ASI	–	440	540	mW	–
		Reset	–	410	–	mW	–
		Standby	–	23	45	mW	–
Digital I/O							
Input Logic LOW	V_{IL}	3.3V or 1.8V operation	IO_VSS -0.3	–	0.3 x IO_VDD	V	–
Input Logic HIGH	V_{IH}	3.3V or 1.8V operation	0.7 x IO_VDD	–	IO_VDD +0.3	V	–

Table 2-3: DC Electrical Characteristics (Continued)

Guaranteed over recommended operating conditions unless otherwise noted.

Parameter	Symbol	Conditions	Min	Typ	Max	Units	Notes
Output Logic LOW	V_{OL}	IOL = 5mA, 1.8V operation	–	–	0.2	V	–
		IOL = 8mA, 3.3V operation	–	–	0.4	V	–
Output Logic HIGH	V_{OH}	IOH = 5mA, 1.8V operation	1.4	–	–	V	–
		IOH = 8mA, 3.3V operation	2.4	–	–	V	–
Serial Input							
Serial Input Common Mode Voltage	–	75Ω load	–	2.2	–	V	–
Serial Output							
Serial Output Common Mode Voltage	–	50Ω load	BUFF_VDD -(0.6/2)	BUFF_VDD -(0.45/2)	BUFF_VDD -(0.35/2)	V	–

Notes:

The output drive strength of the digital outputs can be programmed through the host interface. please see [Table 4-29: Video Core Configuration and Status Registers](#), register 06Dh for details.

2.4 AC Electrical Characteristics

Table 2-4: AC Electrical Characteristics

Guaranteed over recommended operating conditions unless otherwise noted.

Parameter	Symbol	Conditions	Min	Typ	Max	Units	Notes
System							
Device Latency: AUDIO_EN = 1, SMPTE mode, IOPROC_EN = 1	-	3G (Level A)	80	-	83	PCLK	-
		3G (Level B)	143	-	151	PCLK	-
		HD	80	-	83	PCLK	-
		SD	50	-	55	PCLK	-
Device Latency: AUDIO_EN = 0, SMPTE mode, IOPROC_EN = 1	-	3G (Level A)	44	-	48	PCLK	-
		3G (Level B)	108	-	116	PCLK	-
		HD	44	-	48	PCLK	-
		SD	44	-	48	PCLK	-
Device Latency: AUDIO_EN = 0, SMPTE mode, IOPROC_EN = 0	-	3G (Level A)	33	-	36	PCLK	-
		HD	33	-	36	PCLK	-
		SD	32	-	35	PCLK	-
Device Latency: AUDIO_EN = 0, SMPTE bypass, IOPROC_EN = 0	-	3G (Level A)	6	-	9	PCLK	-
		HD	6	-	9	PCLK	-
		SD	5	-	9	PCLK	-
Device Latency: DVB-ASI	-	SD	12	-	16	PCLK	-
Reset Pulse Width	t _{reset}	-	1	-	-	ms	-
Parallel Output							
Parallel Clock Frequency	f _{PCLK}	-	13.5	-	148.5	MHz	-
Parallel Clock Duty Cycle	DC _{PCLK}	-	40	-	60	%	-

Table 2-4: AC Electrical Characteristics (Continued)

Guaranteed over recommended operating conditions unless otherwise noted.

Parameter	Symbol	Conditions	Min	Typ	Max	Units	Notes			
Output Data Hold Time (1.8V)	t_{oh}	3G 10-bit 6pF Cload	SPI	1.5	–	–	ns	1		
			AUDIO	1.5	–	–	ns	1		
			DBUS	0.4	–	–	ns	1		
			STAT	0.45	–	–	ns	1		
		3G 20-bit 6pF Cload	DBUS	1.0	–	–	ns	1		
			STAT	1.0	–	–	ns	1		
		HD 10-bit 6pF Cload	DBUS	1.0	–	–	ns	1		
			STAT	1.0	–	–	ns	1		
		HD 20-bit 6pF Cload	DBUS	1.0	–	–	ns	1		
			STAT	1.0	–	–	ns	1		
		SD 10-bit 6pF Cload	DBUS	19.4	–	–	ns	1		
			STAT	19.4	–	–	ns	1		
		SD 20-bit 6pF Cload	DBUS	38.0	–	–	ns	1		
			STAT	38.0	–	–	ns	1		
		Output Data Hold Time (3.3V)	t_{oh}	3G 10-bit 6pF Cload	SPI	1.5	–	–	ns	2
					AUDIO	1.5	–	–	ns	2
DBUS	0.45				–	–	ns	2		
STAT	0.45				–	–	ns	2		
3G 20-bit 6pF Cload	DBUS			1.0	–	–	ns	2		
	STAT			1.0	–	–	ns	2		
HD 10-bit 6pF Cload	DBUS			1.0	–	–	ns	2		
	STAT			1.0	–	–	ns	2		
HD 20-bit 6pF Cload	DBUS			1.0	–	–	ns	2		
	STAT			1.0	–	–	ns	2		
SD 10-bit 6pF Cload	DBUS			19.4	–	–	ns	2		
	STAT			19.4	–	–	ns	2		
SD 20-bit 6pF Cload	DBUS			38.0	–	–	ns	2		
	STAT			38.0	–	–	ns	2		

Table 2-4: AC Electrical Characteristics (Continued)

Guaranteed over recommended operating conditions unless otherwise noted.

Parameter	Symbol	Conditions	Min	Typ	Max	Units	Notes			
Output Data Delay Time (1.8V)	t_{od}	3G 10-bit 15pF Cload	SPI	–	–	14.0	ns	3		
			AUDIO	–	–	7.0	ns	3		
			DBUS	–	–	1.8	ns	3		
			STAT	–	–	2.5	ns	3		
		3G 20-bit 15pF Cload	DBUS	–	–	3.7	ns	3		
			STAT	–	–	4.4	ns	3		
		HD 10-bit 15pF Cload	DBUS	–	–	3.7	ns	3		
			STAT	–	–	4.4	ns	3		
		HD 20-bit 15pF Cload	DBUS	–	–	3.7	ns	3		
			STAT	–	–	4.4	ns	3		
		SD 10-bit 15pF Cload	DBUS	–	–	22.2	ns	3		
			STAT	–	–	22.2	ns	3		
		SD 20-bit 15pF Cload	DBUS	–	–	41.0	ns	3		
			STAT	–	–	41.0	ns	3		
		Output Data Delay Time (3.3V)	t_{od}	3G 10-bit 15pF Cload	SPI	–	–	14.0	ns	4
					AUDIO	–	–	7.0	ns	4
DBUS	–				–	1.9	ns	4		
STAT	–				–	2.2	ns	4		
3G 20-bit 15pF Cload	DBUS			–	–	3.7	ns	4		
	STAT			–	–	4.1	ns	4		
HD 10-bit 15pF Cload	DBUS			–	–	3.7	ns	4		
	STAT			–	–	4.1	ns	4		
HD 20-bit 15pF Cload	DBUS			–	–	3.7	ns	4		
	STAT			–	–	4.1	ns	4		
SD 10-bit 15pF Cload	DBUS			–	–	22.2	ns	4		
	STAT			–	–	22.2	ns	4		
SD 20-bit 15pF Cload	DBUS			–	–	41.0	ns	4		
	STAT			–	–	41.0	ns	4		

Table 2-4: AC Electrical Characteristics (Continued)

Guaranteed over recommended operating conditions unless otherwise noted.

Parameter	Symbol	Conditions	Min	Typ	Max	Units	Notes			
Output Data Rise/Fall Time (1.8V)	t_r/t_f	3G 10-bit 6pF Cloud	STAT	–	–	0.4	ns	1		
			DBUS	–	–	0.3	ns	1		
			AUDIO	–	–	0.6	ns	1		
		All other modes 6pF Cloud	STAT	–	–	0.4	ns	1		
			DBUS	–	–	0.4	ns	1		
			AUDIO	–	–	0.6	ns	1		
		3G 10-bit 15pF Cloud	STAT	–	–	1.5	ns	3		
			DBUS	–	–	1.1	ns	3		
			AUDIO	–	–	2.3	ns	3		
		All other modes 15pF Cloud	STAT	–	–	1.5	ns	3		
			DBUS	–	–	1.4	ns	3		
			AUDIO	–	–	2.3	ns	3		
Output Data Rise/Fall Time (3.3V)	t_r/t_f	3G 10-bit 6pF Cloud	STAT	–	–	0.5	ns	2		
			DBUS	–	–	0.4	ns	2		
			AUDIO	–	–	0.6	ns	2		
		All other modes 6pF Cloud	STAT	–	–	0.5	ns	2		
			DBUS	–	–	0.4	ns	2		
			AUDIO	–	–	0.6	ns	2		
		Output Data Rise/Fall Time (3.3V)	t_r/t_f	3G 10-bit 15pF Cloud	STAT	–	–	1.6	ns	4
					DBUS	–	–	1.5	ns	4
					AUDIO	–	–	2.2	ns	4
All other modes 15pF Cloud	STAT			–	–	1.6	ns	4		
	DBUS			–	–	1.4	ns	4		
	AUDIO			–	–	2.2	ns	4		
Serial Digital Input										
Serial Input Data Rate	DR_{SDI}	–	0.27	–	2.97	Gb/s	–			
Serial Input Voltage Swing	ΔV_{SDI}	$T_A=25^\circ\text{C}$, differential, 270Mb/s & 1.485Gb/s	720	800	950	mV _{p-p}	6			
		$T_A=25^\circ\text{C}$, differential, 2.97Gb/s	720	800	880	mV _{p-p}	6			
Achievable Cable Length	–	Belden 1694A cable, 3G	–	150	–	m	–			
		Belden 1694A cable, HD	–	230	–	m	–			
		Belden 1694A cable, SD	–	460	–	m	–			

Table 2-4: AC Electrical Characteristics (Continued)

Guaranteed over recommended operating conditions unless otherwise noted.

Parameter	Symbol	Conditions	Min	Typ	Max	Units	Notes
Input Return Loss	–	single ended	15	21	–	dB	7
Input Resistance	–	single ended	–	1.52	–	k Ω	–
Input Capacitance	–	single ended	–	1	–	pF	–
Serial Digital Output							
Serial Output Data Rate	DR _{SDO}	–	0.27	–	2.97	Gb/s	–
Serial Output Swing	ΔV_{SDO}	Differential with 100 Ω load	320	–	600	mVp-p	–
Serial Output Rise Time 20% ~ 80%	tr _{SDO}	–	–	–	180	ps	–
Serial Output Fall Time 20% ~ 80%	tf _{SDO}	–	–	–	180	ps	–
Serial Output Jitter with loop-through mode	t _{OJ}	3G, PRBS23, Belden 1694A cable, 140m	–	–	100	ps	–
		HD, PRBS23, Belden 1694A cable, 210m	–	–	100	ps	–
		SD, PRBS23, Belden 1694A cable, 440m	–	–	470	ps	–
Serial Output Duty Cycle Distortion	DCD _{SDD}	3G	–	10	–	ps	–
		HD	–	10	–	ps	–
		SD	–	20	–	ps	–
Synchronous lock time	–	–	–	–	25	μ s	–
Asynchronous lock time	–	–	0.1	–	20	ms	–
Lock time from power-up	–	After 20 minutes at -20°C	–	–	5	s	–
GSPI							
GSPI Input Clock Frequency	f _{SCLK}	–	–	–	60	MHz	5
GSPI Input Clock Duty Cycle	DC _{SCLK}	50% levels 3.3V or 1.8V operation	40	50	60	%	5
GSPI Input Data Setup Time	–		1.5	–	–	ns	5
GSPI Input Data Hold Time	–		1.5	–	–	ns	5
GSPI Output Data Hold Time	–	–	1.5	–	–	ns	5
\overline{CS} low before SCLK rising edge	–	50% levels 3.3V or 1.8V operation	1.5	–	–	ns	5
Time between end of command word (or data in Auto-Increment mode) and the first SCLK of the following data word - write cycle	–	50% levels 3.3V or 1.8V operation	37.1	–	–	ns	5

Table 2-4: AC Electrical Characteristics (Continued)

Guaranteed over recommended operating conditions unless otherwise noted.

Parameter	Symbol	Conditions	Min	Typ	Max	Units	Notes
Time between end of command word (or data in Auto-Increment mode) and the first SCLK of the following data word - read cycle	–	50% levels 3.3V or 1.8V operation	148.4	–	–	ns	5
\overline{CS} high after SCLK falling edge	–	50% levels 3.3V or 1.8V operation	37.1	–	–	ns	5

Notes:

1. 1.89V and 0°C.
2. 3.47V and 0°C.
3. 1.71V and 85°C
4. 3.13V and 85°C
5. Timing parameters defined in [Section 4.20.3](#)
6. 0m cable length
7. Tested on a 2971 board from 5MHz to 3GHz.